

**CROWN AND ROOT PRUNING OF FOUR YEAR OLD BOUNDARY
TREES AT SIAYA AND NYABEDA IN WESTERN KENYA: SOCIO-
ECONOMICS, UTILIZATION OF SOIL WATER, AND MAIZE AND WOOD
YIELDS**

BY

ALMAZ TEKLEBERHAN TEFERA



**A THESIS SUBMITTED IN FULFILLMENT OF THE REQUIREMENTS
FOR THE DEGREE OF DOCTOR OF PHILOSOPHY OF THE SOKOINE
UNIVERSITY OF AGRICULTURE. MOROGORO, TANZANIA.**

2004



ABSTRACT

Farmers' survey and two field experiments were carried out at Siaya and Nyabeda in western Kenya to investigate the effect of crown and root pruning on tree growth, soil water dynamics, maize and wood yields, when trees are boundary planting along agricultural crops. The experiment carried out at Siaya included 4 years old trees of *Casuarina equisetifolia*, *Eucalyptus grandis*, *Grevillea robusta* and *Markhamia lutea* while the one carried out at Nyabeda involved 5 years old *G. robusta*. The following parameters were assessed over 5 and 4 cropping seasons at Siaya and Nyabeda respectively: tree growth, light interception, soil water dynamics, tree water uptake and maize yield. Results from the Siaya survey showed that 74% of the farmers grow *M. lutea* on their farms, which is an indigenous tree species in western Kenya. Eighty-four percent of the respondents observed that crop yields that are close to the trees were very low compared to crops that were far away from the trees. The result from the experimental data showed that all the four tree species in the test at both sites survived both heavy crown and root pruning without any mortality or reduced growth. Tree species showed significant ($P < 0.001$) variability in branch biomass produced from crown pruning at Siaya site. *Eucalyptus grandis* had the highest biomass (107.2 kg/tree) production at the time of first pruning while *M. lutea* had the lowest (5.5 kg/tree). New branch sprouts of pruned trees continued to grow in both length and diameter. *Eucalyptus grandis* had the highest growth in both new branch length and basal diameter (10.49 m and 13.44 cm respectively) while *M. lutea* had the least (5.39 m and 6.75 cm respectively). Soil water under crown and root pruned trees were significantly ($P < 0.05$) high compared to the unpruned (control) tree plots.

Soil water content decreased by 25-35% under un-pruned (control) tree plots of all species as compared to soil water content under crown and root pruned tree plots. Transpiration of crown and crown plus root pruned *C. equisetifolia* and *G. robusta* trees was reduced by 50% as compared to unpruned trees. Maize grain yield was positively influenced by photosynthetically active radiation (PAR) under both *C. equisetifolia* ($R^2 = 0.84$) and *E. grandis* ($R^2 = 0.97$) boundary trees. During the first 3 maize cropping seasons, maize crops adjacent to pruned trees produced significantly ($P < 0.01$) higher yield (50-80%) compared to that growing adjacent to the unpruned (control) trees. Based on maize yield production, crown only pruning is recommended for *M. lutea* and *E. grandis* trees while crown plus root pruning is recommended for *C. equisetifolia* trees. Root only pruning is recommended for *G. robusta* trees. Trees of all species need to be re-pruned every 1-2 years.

DECLARATION

I, ALMAZ TEKLEBERHAN TEFERA, do hereby declare to the Senate of Sokoine University of Agriculture that this thesis is my own original work and has never been submitted nor is it being concurrently submitted for a degree award in any other University.

Signature. 

Date. 

COPYRIGHT

No part of this thesis may be reproduced, stored in a retrieval system or transmitted in any form or by any means without prior written permission of the author or Sokoine University of Agriculture in that behalf.

ACKNOWLEDGEMENTS

I would like to express my gratitude to many people. First and foremost, to my late Grandfather, Tefera Yifru, whose memories the family will always cherish. To my parents, (Stedale and Tekleberhan) for enduring my long absence from home; my sisters (Bertukan, Workinesh, Martha) and brothers (Hailu, Assefa, Kasahun, Solomon) for their moral support and encouragement. To Alemsthayе Girma, for taking care of my personal matters back at home.

I would like to express my gratitude to ICRAF for covering expenses of my research work in western Kenya. The additional research funds from IFS and DFID is highly acknowledged.

Sentiment of gratitude goes to Prof. A.G. Mugasha, Sokoine University of Agriculture (SUA), who on top of his teaching load and other duties, supervised patiently the whole of this work. My sincere gratitude also goes to Prof. S.A.O. Chamshama, Department of Forest Biology, for his support and valuable comments on the whole of this thesis.

Many thanks are due to the staff and members of the Faculty of Forestry and Nature Conservation: Dean of the Faculty, Prof. G.C. Monela; Associate Dean, Prof. P. Gillah; Head of the Department of Forest Biology, Prof. V.R. Nsolomo; Former Dean of the Faculty, Prof. R.C. Ishengoma; Former Head of the Department, Prof.

S.M.S. Maliondo; Members of the Department, Prof. L.L.L. Lulandala; Prof. R.P.C. Tcmu, Prof. R.E. Malimbwi; Prof. S.S. Madoffe; Dr. P.K.T. Munishi and E. Zahabu, are among the few names to mention. V.V.K. Gerald; H. Senkondo; E. Mtambo; C. Sakaya, H. Nzige and Z. Ibrahim I thank them all for their support and the friendly environment at SUA. The support from the office of the Director of Research and Postgraduate Studies under the leadership of Prof. W.A.S Abeli is highly appreciated.

Sincere thanks go to Prof. C.K. Ong, ICRAF, who co-supervised this work. The support from Prof A. Tcmu and K. Attakrah, ICRAF, is highly appreciated. Special thanks also go to Dr. J. Wilson and Dr. D. J. Deans, CEH, UK, for valuable comments.

My thanks go to ICRAF staff at the Maseno station. Special thanks go to R. Simone, C. Japheth, K. Sammy, N. Mutava and J. Atieno.

Sincere thanks to all staff at ICRAF headquarters. Z. Dossa; M. Ndungu; R. Mulunge; C. Muthuri and J.M. Mulatya are among few names. I would also like to extend my gratitude to all the farmers involved in the survey and field work of this study.

The acknowledgements surely, would not be complete without thanking my wonderful husband, Bekele Belew Reta, for his understanding, encouragement and patience, even at times of extreme difficulties.

DEDICATION

To my late grand father Kibure Ato Tefera Yifru Yctenoru for his dedication to hard work and guiding principles.

To all my sisters and brothers for their constant encouragement and moral support.

To my wonderful husband Bekele Belew Reta whose constant inspiration made these all possible.

TABLE OF CONTENTS

	Page no.
ABSTRACT	ii
DECLARATION.....	iv
COPYRIGHT	v
ACKNOWLEDGEMENTS	vi
DEDICATION	viii
TABLE OF CONTENTS.....	ix
LIST OF TABLES.....	xv
LIST OF FIGURES	xxi
LIST OF APPENDICES.....	xxvi
LIST OF ABBREVIATIONS AND SYMBOLS.....	xxvii
CHAPTER ONE.....	1
1.0 INTRODUCTION	1
1.1 Introduction to AF and its components	1
1.2 Boundary tree planting in AF system.....	2
1.3 Problem analysis and justification	5
1.3.1 The need for socio-economic survey.....	5
1.3.2 The need for tree pruning study	7
1.4 Objectives and hypothesis	11
1.4.1 Objectives	11

1.4.2	The alternative hypotheses.....	12
CHAPTER TWO.....		13
2.0	LITERATURE REVIEW.....	13
2.1	Farmers' survey.....	13
2.1.1	Background.....	13
2.1.2	Why socio-economic survey.....	14
2.2	Tree-crop interaction.....	16
2.2.1	Background.....	16
2.2.2	Competition and complementarity in AF systems.....	21
2.3	Soil water.....	34
2.4	Sap flow.....	38
2.4.1	Water uptake by trees.....	38
2.4.2	Sap flow in plants.....	43
2.4.3	Application of sap flow techniques.....	43
2.5	Light capture and utilization in AF systems.....	53
2.5.1	Theory.....	53
2.5.2	Light interception in boundary tree planting AF.....	56
2.5.3	Methods of measuring light interception in AF systems.....	58
2.6	Description of study tree species.....	59
2.6.1	<i>Casuarina equisetifolia</i>	60
2.6.2	<i>Eucalyptus grandis</i>	66
2.6.3	<i>Grevillea robusta</i>	70
2.6.4	<i>Markhamia lutea</i>	76

LIST OF FIGURES

Figure 3.1:	Location of Siaya and Nyabeda experimental sites in western Kenya....	82
Figure 3.2:	Mean monthly rainfall distribution for (a) Siaya and (b)_Nyabeda (1998-2000) in western Kenya.....	84
Figure 3.3:	Experimental layout of Siaya, western Kenya	86
Figure 3.4:	A field layout showing the arrangement of trees and maize rows in a plot at Siaya, western Kenya.....	88
Figure 3.5:	Experimental layout of Nyabeda, western Kenya	90
Figure 3.6:	A field layout showing the arrangement of trees and maize rows in a plot at Nyabeda, western Kenya.....	92
Figure 3.7:	Illustration of a set of heat pulse gauges inserted into a stem	107
Figure 4.2.1:	Mean DBH development over time in relation to tree species and pruning treatments at Siaya, western Kenya.....	139
Figure 4.2.2:	Mean DBH development (a) and Cumulative mean DBH annual increments (b) of the different tree species before and after tree pruning treatments were applied at Siaya, western Kenya.	141
Figure 4.3.1:	Effect of tree pruning and increasing distance from tree lines on mean volumetric soil water content (%) during the 1 st season long-rain, April-May 1999 at Siaya, western Kenya.....	154
Figure 4.3.2:	Effect of tree pruning and increasing distance from tree lines on mean volumetric soil water content during the 2 nd season short-rain, October-November 1999 at Siaya, western Kenya.	156

Figure 4.3.3: Effect of tree pruning and increasing distance from tree lines on mean volumetric soil water content during the 3 rd season long-rain, April-May 2000 at Siaya, western Kenya	157
Figure 4.3.4: Effect of soil depth on pooled mean volumetric soil water content during the April-May long rain 2000 of the 3 rd maize growing season at Siaya, western Kenya.....	166
Figure 4.3.5: Effect of soil depth on pooled mean volumetric soil water content during the June-July long rain 2000 of the 3 rd maize growing season at Siaya, western Kenya.....	167
Figure 4.3.6: Effect soil depth on pooled mean volumetric soil water content (%) during the September-January short rain 2000 of the 4 th maize growing season at Siaya, western Kenya.....	168
Figure 4.3.7: Trends of %VSWC pooled over (a) pruning treatments and (b) over species during the 3 maize growing season at Siaya, western Kenya. ...	170
Figure 4.3.8: Effect of tree pruning on %VSWC trends for all soil depths over 3 maize growing seasons at Siaya, western Kenya.	171
Figure 4.3.9: Mean monthly rainfall canopy throughfall as compared to the rainfall in an open air at Siaya, western Kenya.....	174
Figure 4.3.10: Effects of soil depth and tree root pruning on percent volumetric soil water content pooled for all distances from <i>G. robusta</i> tree line during the short rain 1999, long rain 2000 and short rain 2000 at Nyabeda, western Kenya.....	178

4.7	Trends and relationships between rainfall, percent volumetric soil water content, sap flow, light and maize grain yield at Siaya	212
4.7.1	Effects of Rainfall on %VSWC	213
4.7.2	Influence of %VSWC, sap flow and PAR on maize grain yield	213
4.7.3	The relationship between sap flow of trees subjected to different pruning treatments and %VSWC and PAR at Siaya, western Kenya	218
CHAPTER FIVE		223
5.0	DISCUSSION	223
5.1	General	223
5.2	Farmers' survey, farmers and pole/timber merchants evaluations of trees	224
5.2.1	Farmers' Survey	224
5.2.2	Farmers and pole/timber merchants evaluations of tree species	227
5.3	Tree pruning and tree responses to crown and root prunings	228
5.3.1	Siaya	228
5.3.2	Nyabeda	231
5.4	Soil water	232
5.4.1	Siaya	232
5.4.2	Nyabeda	239
5.5	Sap flow	241
5.5.1	Siaya	242
5.5.2	Nyabeda	243
5.6	Light interception by maize crops in boundary planted trees at Siaya.....	243
5.7	Maize growth and yield response to tree crown and root pruning.....	245

5.7.1	Siaya	245
5.7.2	Nyabeda	249
CHAPTER SIX		251
6.0	CONCLUSIONS AND RECOMMENDATIONS	251
6.1	Conclusions.....	251
6.2	Recommendations	253
REFERENCES.....		254
APPENDICES.....		287

LIST OF TABLES

Table 2.1:	Summaries of wheat yield decreases by distance from tree lines in western Himallia, India.....	30
Table 2.2:	Summaries of effects of boundary planted trees on adjacent crops in the tropics (Percent reduction in PAR reaching crops).	31
Table 2.3:	Summaries of effects of boundary planted trees on adjacent crops in the tropics (percent reduction in crop yields).....	32
Table 3.1:	Some selected properties of soils at Siaya and Nyabeda experimental sites, western Kenya.	85
Table 3.2:	Details of assessments made during the course of the study for Siaya, western Kenya	115
Table 3.3:	Details of assessments made for Nyabeda, western Kenya	116
Table 3.4:	Structure of the ANOVA comparing the different Treatment at Siaya.	118
Table 3.5:	Structure of the ANOVA comparing at Nyabeda.	119
Table 4.1.1:	Farm/household decision makers in Siaya, western Kenya.....	123
Table 4.1.2:	Niches for trees used by respondents in Siaya, western Kenya.	124
Table 4.1.3:	Tree planting arrangements in Siaya, western Kenya.	124
Table 4.1.4:	Categories of tree species planted on-farm in Siaya, western Kenya....	125
Table 4.1.5:	Summary of farmers tree pruning activities in Siaya, western Kenya. .	127
Table 4.1.6:	Time spent on tree pruning in Siaya, western Kenya.	130
Table 4.1.7:	Farmers' evaluation of soils at Siaya, western Kenya.....	131

Table 4.2.1:	Tree survival and mean growth of <i>C. equisetifolia</i> , <i>E. grandis</i> , <i>G. robusta</i> and <i>M. lutea</i> at age 48 months, just before trees were pruned at Siaya, western Kenya.....	135
Table 4.2.2:	Mean scores of stem form, branchiness and canopy spread of trees at age 48 months, just before pruning at Siaya, western Kenya.	135
Table 4.2.3:	Dry biomass produced from crown pruning at age 48 and 53 months at Siaya, western Kenya.....	136
Table 4.2.4:	Time taken in tree pruning at Siaya, western Kenya.....	137
Table 4.2.5:	Firewood consumption and quality ranking of pruning materials at Siaya, western Kenya.....	137
Table 4.2.6:	Overall tree survival and mean DBH at 10 and 24 months after tree pruning at Siaya, western Kenya.....	138
Table 4.2.7:	Mean ranking of sprouting ability of tree species after crown pruning at Siaya, western Kenya.....	140
Table 4.2.8:	Mean new branch number and coppice re-growth of different tree species, at 2 years after pruning at Siaya, western Kenya.	143
Table 4.2.9:	Mean root re-growth (%) potential of pruned tree roots at 2 years after pruning at Siaya, western Kenya.	143
Table 4.2.10:	Tree survival and growth of <i>G. robusta</i> at age 6 years, just before root pruning was imposed at Nyabeda, western Kenya.....	144
Table 4.2.11:	Mean growth parameters for <i>G. robusta</i> trees 1 year after root pruning at Nyabeda, western Kenya.....	145

Table 4.3.1:	Probability values from ANOVA examining the effects of species, tree pruning and increasing distance, and their interaction on %VSWC of the top 30 cm of the soil profile during the 3 maize growing seasons at Siaya, western Kenya	147
Table 4.3.2:	Mean volumetric soil water content of the top 0-30 cm soil layer under different tree species, pruning treatments and all distances at Siaya, western Kenya.....	148
Table 4.3.3:	Half matrix of pair wise comparisons of tree species and pruning treatments for mean volumetric soil water content pooled for all distances and depths for 1 st season long rain 1999 at Siaya, western Kenya.....	149
Table 4.3.4:	Mean volumetric soil water content of the top 0-30 cm soil layer under different tree species, pruning treatments and all distances at Siaya, western Kenya.....	150
Table 4.3.5:	Half matrix of pair wise comparisons of tree species and pruning treatments for mean volumetric soil water content pooled for all distances and depths for 2 nd season short rain 1999 at Siaya, western Kenya.....	151
Table 4.3.6:	Overall mean volumetric soil water content in the top 0-30 cm soil layer under different tree species at Siaya, western Kenya.....	152
Table 4.3.7:	Half matrix of pair wise comparisons of tree species and pruning treatments for mean volumetric soil water content pooled for all distances and depths for 3 rd season long rain 2000 at Siaya, western Kenya.....	153

Table 4.3.8: Probability values from ANOVA examining the effect of species, pruning treatments, soil depth of and distance from tree lines and their interactions on %VSWC during long and short rains 2000, at Siaya, western Kenya.....	160
Table 4.3.9: Mean volumetric soil water content under species and pruning treatments for all soil depths and distances at Siaya, western Kenya. ..	161
Table 4.3.10: Mean volumetric soil water content for all pruning treatments and all distances under tree species at Siaya, western Kenya.	162
Table 4.3.11: Half matrix of pair wise comparisons of tree species and pruning treatments for mean volumetric soil water content pooled for all distances and depths for 4 th season short rain 2000 at Siaya, western Kenya.....	163
Table 4.3.12: Effect of soil depth on mean volumetric soil water content for all pruning treatments and distances under tree species at Siaya, western Kenya.....	164
Table 4.3.13: Effect of soil depth on mean volumetric soil water content for all pruning treatments and distances under tree species at Siaya, western Kenya.....	165
Table 4.3.14: Summaries of probability values for greater F-ratio from ANOVA examining effects of root pruning treatments, soil depth and distance from tree lines and their interactions on %VSWC during the maize growing seasons of short rain of 1999, long rain of 2000 and short rain of 2000, at Nyabeda, western Kenya.....	175

Table 4.3.15: Effect of tree root pruning on volumetric soil water content pooled for all depths and distances from tree lines for January 2000 to January 2001 period at Nyabeda, western Kenya.	175
Table 4.3.16: Effect of soil depth on %VSWC pooled for all distances and treatments during the 3 maize cropping seasons at Nyabeda, western Kenya.	177
Table 4.5.1: Light intercepted by 4 boundary planted tree species, immediately after pruning, during the first maize cropping season of the long rain in 1999 at Siaya, western Kenya.	189
Table 4.5.2: Probability values for greater F-ratio for ANOVA of the effect of species, treatments and rows of maize from tree lines and their interactions on PAR by trees (a) and Maize (b) at Siaya, western Kenya.	191
Table 4.5.3: Mean of fractional light intercepted by maize crops during the 4 cropping seasons at Siaya, western Kenya.	191
Table 4.6.1: Probability values for greater F-ratios for the effect of species, treatments and rows of maize from tree lines and their interaction at 3, 6, and 8 weeks after maize planting for maize growths, plant and cob numbers during the first season long rain in 1999 at Siaya, western Kenya.	199
Table 4.6.2: The effect of tree pruning on maize height and root collar diameter at 3, 6 and 8 weeks after planting during the long rain in 1999 at Siaya, western Kenya.	202

Table 4.6.3:	Effects of tree species and pruning treatments on maize plant and cob numbers during the long rains of 1999 at Siaya, western Kenya.....	203
Table 4.6.4:	Probability for greater F-ratio values for effect of species, pruning treatments and distance of maize rows from tree lines and their interactions on maize yield over the different cropping seasons at Siaya, western Kenya.....	204
Table 4.6.5:	Effects of tree pruning treatments on dry maize cobs yield over five cropping seasons at Siaya, western Kenya.	206
Table 4.6.6:	Effects of tree pruning treatments on dry maize grain yield over five cropping seasons at Siaya, western Kenya.	207
Table 4.6.7:	Probability for greater F-ratio values of the effect of root pruning and increasing distance of maize rows from pruned tree lines and their interactions on maize cobs dry weight (kg/ha) and maize grain yield during different cropping seasons at Nyabeda, western Kenya.	210
Table 4.6.8:	Effect of tree root pruning on maize grain yield during the four cropping seasons at Nyabeda, western Kenya.	211

LIST OF FIGURES

Figure 3.1:	Location of Siaya and Nyabeda experimental sites in western Kenya....	82
Figure 3.2:	Mean monthly rainfall distribution for (a) Siaya and (b)_Nyabeda (1998-2000) in western Kenya.....	84
Figure 3.3:	Experimental layout of Siaya, western Kenya	86
Figure 3.4:	A field layout showing the arrangement of trees and maize rows in a plot at Siaya, western Kenya.....	88
Figure 3.5:	Experimental layout of Nyabeda, western Kenya	90
Figure 3.6:	A field layout showing the arrangement of trees and maize rows in a plot at Nyabeda, western Kenya.....	92
Figure 3.7:	Illustration of a set of heat pulse gauges inserted into a stem	107
Figure 4.2.1:	Mean DBH development over time in relation to tree species and pruning treatments at Siaya, western Kenya.....	139
Figure 4.2.2:	Mean DBH development (a) and Cumulative mean DBH annual increments (b) of the different tree species before and after tree pruning treatments were applied at Siaya, western Kenya.	141
Figure 4.3.1:	Effect of tree pruning and increasing distance from tree lines on mean volumetric soil water content (%) during the 1 st season long-rain, April-May 1999 at Siaya, western Kenya.....	154
Figure 4.3.2:	Effect of tree pruning and increasing distance from tree lines on mean volumetric soil water content during the 2 nd season short-rain, October-November 1999 at Siaya, western Kenya.	156

- Figure 4.3.3: Effect of tree pruning and increasing distance from tree lines on mean volumetric soil water content during the 3rd season long-rain, April-May 2000 at Siaya, western Kenya. 157
- Figure 4.3.4: Effect of soil depth on pooled mean volumetric soil water content during the April-May long rain 2000 of the 3rd maize growing season at Siaya, western Kenya..... 166
- Figure 4.3.5: Effect of soil depth on pooled mean volumetric soil water content during the June-July long rain 2000 of the 3rd maize growing season at Siaya, western Kenya..... 167
- Figure 4.3.6: Effect soil depth on pooled mean volumetric soil water content (%) during the September-January short rain 2000 of the 4th maize growing season at Siaya, western Kenya..... 168
- Figure 4.3.7: Trends of %VSWC pooled over (a) pruning treatments and (b) over species during the 3 maize growing season at Siaya, western Kenya... 170
- Figure 4.3.8: Effect of tree pruning on %VSWC trends for all soil depths over 3 maize growing seasons at Siaya, western Kenya. 171
- Figure 4.3.9: Mean monthly rainfall canopy throughfall as compared to the rainfall in an open air at Siaya, western Kenya..... 174
- Figure 4.3.10: Effects of soil depth and tree root pruning on percent volumetric soil water content pooled for all distances from *G. robusta* tree line during the short rain 1999, long rain 2000 and short rain 2000 at Nyabeda, western Kenya..... 178

Figure 4.3.11: Effect of distance and tree root pruning on percent volumetric soil water content pooled for all depths during the short rain 1999, long rain 2000 and short rain 2000 at Nyabeda, western Kenya.	180
Figure 4.3.12: Mean trends of %VSWC pooled for all soil depths and distances from tree line over three seasons at Nyabeda, western Kenya.	181
Figure 4.4.1: Trends of transpiration rates averaged for (a) all days and (b) hours/day for <i>C. equisetifolia</i> during the 4 th cropping season i.e. short rain 2000, 2 years after pruning, at Siaya, western Kenya.	183
Figure 4.4.2: Trends of transpiration rates averaged for (a) all days and (b) hours/day for <i>G. robusta</i> during the 4 th cropping season i.e. short rain 2000, 2 years after pruning, at Siaya, western Kenya.	184
Figure 4.4.3: Trends of transpiration rates averaged for all (a) days and (b) hours/day for <i>G. robusta</i> during the 2 nd cropping season i.e. long rain 2000 at Nyabeda, western Kenya.	186
Figure 4.5.1: Effect of trees and pruning treatments on the mean (4 measurements) fraction of incoming PAR reaching the maize crop for (a) March – May 1999 and (b) September – November 2000 cropping seasons at Siaya, western Kenya.....	190
Figure 4.5.2: Effects of tree pruning on the mean PAR fractional interception by maize foliage for April-May 1999 at Siaya, western Kenya.....	192
Figure 4.5.3: Effects of tree pruning on the mean PAR fractional interception by maize foliage for October-November 1999 at Siaya, western Kenya...	193
Figure 4.5.4: Effects of tree pruning on the mean PAR fractional interception by maize foliage for April-May 2000 at Siaya, western Kenya.....	195

Figure 4.5.5: Effects of tree pruning on the mean PAR fractional interception by maize foliage for October-November 2000 at Siaya, western Kenya...	197
Figure 4.6.1: Effect of tree pruning maize yield at Siaya, western Kenya.....	208
Figure 4.6.2: The effect of increasing distance from pruned trees on maize grain yield during the short rains maize cropping season of 1999 and 2000 at Siaya, western Kenya.....	209
Figure 4.6.3: Effect of increasing distance from the line of pruned trees on the maize above ground biomass at Siaya, western Kenya.	210
Figure 4.6.4: Effect of increasing distance from tree line on maize grain yield at Nyabeda, western Kenya.	212
Figure 4.7.1: Effects of mean rainfall received on mean %VSWC of all sampled distances from tree lines and soil depths over three maize cropping seasons (1 st season long rain 1999, 2 nd season short rain 1999 and 3 rd season long rain 2000) at Siaya, western Kenya.	214
Figure 4.7.2: Effects of mean %VSWC of all sampled distances from tree lines and soil depths on maize grain yield during long and short rains 1999 at Siaya, western Kenya.....	216
Figure 4.7.3: Relationships between maize grain yield and %VSWC during the 1 st (long rain 1999) and 2 nd (short rain 1999) maize cropping seasons at Siaya, western Kenya.....	217
Figure 4.7.4: Mean relationships between maize grain yield and sap flow of <i>C. equisetifolia</i> (a) and <i>G. robusta</i> (b) during the 3 rd (long rain 2000) & 4 th (short rain 2000) maize cropping seasons at Siaya, western Kenya.	218

- Figure 4.7.5: Mean relationships between maize grain yield and PAR under 4 boundary planted trees during the 1st (long rain 1999) and the 4th (short rain 2000) maize cropping seasons at Siaya, western Kenya..... 219
- Figure 4.7.6: Trends for PAR as % of sole maize and maize yield as a % of sole maize plots during the 1st (long rain 1999) and 2nd (short rain 1999) seasons of maize planting at Siaya, western Kenya. 220
- Figure 4.7.7: Relationships between %VSWC and Sap flow for all distance from the tree line and soil depths for *C. equisetifolium* and *G. robusta* subjected to different pruning treatments during the 3rd & 4th season of long rain 2000 at Siaya, western Kenya. 221
- Figure 4.7.8: The mean relationships between PAR interception and sap flow under boundary trees during the 4th maize cropping season at Siaya, western Kenya..... 222

LIST OF APPENDICES

APPENDIX 1:	Questionnaire for a targeted survey of farmers in western Kenya.....	287
APPENDIX 2:	Informal questions assessed in western Kenya.....	293

LIST OF ABBREVIATIONS AND SYMBOLS

AF	Agroforestry
AFRENA	Agroforestry Research Network for Africa
ANAFE	African Network for Agroforestry Education
ANOVA	Analysis of Variance
ASC	Amorphous Silicium Cells
CEH	Centre for Ecology and Hydrology
°C	Degree Centigrade
cm³	Cubic centimetre
CO₂	Carbon dioxide
cm	Centimetre
DBH	Diameter at Breast Height
DW	Dry weight
EARO	Ethiopian Agricultural Research Organization
FRC	Forestry Research Centre
FAO	Food and Agricultural Organization of the United Nations
FW	Fresh weight
F.p	Fisher's Probability
ha	Hectare
ICRAF	International Centre for Research in Agroforestry
KEFRI	Kenya Forestry Research Institute
Kg	Kilogram
KSh	Kenyan Shillings

LR	Long-rains
Lsd	Least Significant Difference
m	Meter
m³	Cubic meter
mm	Millimetre
N	Number
NGO	Non Governmental Organization
P	Probability level
PAR	Photosynthetically Active Radiation
RCBD	Randomized Complete Block Design
SE	Standard error of the mean
S.E.D	Standard error of the difference of means
SR	Short-rains
Spp.	Species
SPSS	Statistical Package for Social Sciences
TSP	Triple Super Phosphate
UK	United Kingdom
UNESCO	United Nations Educational, Scientific and Cultural Organization
US\$	US Dollar
VSWC	Volumetric Soil Water Content

CHAPTER ONE

1.0 INTRODUCTION

This Chapter is divided into four sections. Section 1.1 presents an introduction to Agroforestry and its components. Section 1.2 gives background information on boundary trees in Agroforestry system, while problem analysis and justification for both socioeconomic and biophysical studies are presented in section 1.3. The objectives and the hypothesis of the study are presented in section 1.4.

1.1 Introduction to Agroforestry and its components

Agroforestry (AF) is generally defined as farming systems whereby trees and crops and/or animals are integrated in the same farm area, either spatially or temporally. It is expected to maximize biological and economic productivity of the farmland (Rocheleau, *et al.*, 1988; Nair, 1991). A recent definition of AF states that it is a land use system in which trees or shrubs are grown in association with agricultural crops, pasture and/or livestock in a spatial arrangement, rotation or both, and in which there are both ecological and economic interactions between the tree and other components of the system (Leakey, 1996; Young, 1997). Such a system increases exploitation of resources by effectively growing trees and crops at the same time or in rotation on a single piece of land (Nair, 1991). Although AF has long been traditionally practiced by farmers, it is only comparatively recently that this land use practice has been studied by scientists and economists.

The AF approaches of incorporating woody perennials (tree/shrubs) into existing farming systems have the potential for providing both high productivity and maintain environmental services. Trees and shrubs have the potential of providing wood products (e.g. fuelwood, food, and fodder) as well as providing services such as soil erosion control (Young, 1989; Lal, 1989; Kakuru, 1993; Kiepe and Rao, 1994; Young, 1997) and soil fertility improvement (Campbell *et al.*, 1992; Palm, 1995; Bursh and Tian, 1997). The major AF systems that are practiced in tropical agriculture include: dispersed trees on cropland, alley cropping, relay cropping, trees on home gardens, rotational woodlots, improved fallows, and trees on farm boundaries (Rocheleau, *et al.*, 1988).

1.2 Boundary tree planting in AF system

Planting trees along the farm and field boundaries (boundary plantings) is one of the traditional AF technologies practiced in most African highlands (Von Maydell, 1987; MacDicken, 1990). Woody perennials are grown in one or two lines to mark boundaries and provide windbreaks, shade and wood production for household needs. Tree species that are commonly grown in this way in East Africa include trees such as *G. robusta* and *E. grandis* species (Rocheleau *et al.*, 1988). The trees are grown for production of construction poles, fuelwood and/or fodder for livestock. Evans (1988) reported that a one-hectare farm having a 400-m perimeter would accommodate 100 trees of *Eucalyptus* species, 5-6 years old, ($0.1\text{m}^3/\text{tree}$) at 4-m spacing, which may provide adequate fuelwood (open stove) for a household of 7 to 9 people, on rotational basis per year, for several years. This assumes an annual

fuelwood consumption of 0.1m³/person/year. The technology has the potential of benefiting a large number of resource poor farmers. It makes use of areas that are usually under-utilized on the farms and it is not labour intensive.

In western Kenya, a densely populated zone of 300-1000 persons per km² (Swinkels *et al.*, 1997), farm boundaries are increasingly becoming an important niche for planting trees as farm size per household diminish (1-3 ha) and natural wood resources dwindle (Tyndall, 1996). Superficial root systems of boundary trees may reduce loss of nutrients by leaching and runoff and improve soil porosity, infiltration and aeration (Bowen, 1985; Cooper *et al.*, 1996; Buresh and Tian, 1998). Deep roots intercept leached nutrients and recycle them to the surface and may reduce the degree of competition between trees and crops (Cooper *et al.*, 1996).

However, a major constraint to boundary tree plantings by small-scale farmers along agricultural fields is the fear of competition of the trees with food crops for light, space, available nutrients and water. In land scarce areas, such as western Kenya, small-scale farmers would be unwilling to sacrifice crop yields due to competition of trees.

The result of a preliminary informal survey (Wilson *et al.*, 1999) showed that *G. robusta* is the most commonly grown tree species along field boundaries in central Kenya and *M. lutea*, *E. grandis* and *G. robusta* in western Kenya. However, extension of this AF technology to much of the region is limited because farmers observed reduction in crop yields where crops are grown adjacent to boundary

planted trees (Tefera, 1999). It has been observed that this is due to competition of trees and adjacent crops for water, light and nutrients (Neumann and Pietrowicz, 1987; Ong *et al.*, 1992b). Research results (Neumann and Pietrowicz, 1987; Mwihomeke, 1990; Okorio *et al.*, 1994; Akyeampong *et al.*, 1999) and on-farm surveys (Hoekstra *et al.*, 1991; Wilson *et al.*, 1999) have shown that tree competition for growth resources affects crop growth and yield.

The suppressive effect of boundary trees on annual crops has also been reported elsewhere in the tropics (Malik and Sharma, 1990; Puri and Bangarwa, 1992; Kater *et al.*, 1992; Kessler, 1992; Yadar *et al.*, 1993; Dhyani *et al.*, 1996; Maheta *et al.*, 1996).

In-order to encourage farmers to carryout boundary tree planting along agricultural fields, competition between trees and crops should be minimized by tree management (Tefera *et al.*, 2001). In any AF system, trees have to be managed to make them economically profitable on farm. A single tree species can be exploited for its leaves, wood, bark, roots, fruits and so on. Different goals and specific practices correspond to each use. Carrying out tree management practices, such as tree pruning; depend on the products that the farmer would like. For example, the farmer who is looking for light shade should prune his trees differently from the one who wants an abundant harvest of leaves for fodder and/or abundant harvest of branches/wood for fuelwood.

Khybri *et al.* (1992) reported that tree species and distance from tree line in boundary planted AF system significantly reduced the yield of wheat interplanted with *Eucalyptus grandis*, *Grewia optiva* and *Morus alba*. They further reported that wheat yields at various distances from the tree lines showed the lowest values within 1 m. Wheat yields decreases were 49% for 1m, 33% for 1-2 m, 26% for 2-3 m and 16% for 3-5 m distances from the tree lines.

Large differences among species for competitiveness were also observed 3 years after tree establishment on field boundaries by Okorio *et al.* (1994). They reported crop yield reduction from 60% adjacent to the fast growing *Muesopsis eminii*, to 38% in the slow growing *M. lutea*.

1.3 Problem analysis and justification

1.3.1 The need for socio-economic survey

Population increase in the highlands of East and Central Africa has been rapid since the turn of last century, resulting in areas with up to 1000 persons km⁻² in Western Kenya and elsewhere in the region. Individual farms are very small (0.1 – 1.0 ha.) and these limited land holdings often must support up to ten family members (Mugo, 1998). Farmers need food to survive and fuel to cook the food. The increase in population and shortage of land holdings per family will not allow farmers to grow crops and fuel wood on separate plots. Farmers, therefore, are mixing trees and crops on the same piece of land in order to produce both food and fuelwood for household needs. Although they have noticed the reduction in crop yields when trees are grown

adjacent to food crops, they have little knowledge to overcome the problem. Farmers either suffer loss of crops and get wood from the intercropped plots or stop growing trees in agricultural fields and suffer from the shortage of wood, which is vital to the well being of any farm family.

Trees are hardly noticeable when first planted in the field but in time they grow to considerable size. As the years go by they demand more room both above and below the ground. The occupation of the fields and the arrangement of the canopy layers evolve in the same way and hence above-ground and below-ground competitions of trees with crops. However, there are several questions which should be answered before carrying out any field experiment and transfer of new or modified technology to farmers' fields. Therefore, evaluation of existing farmers' knowledge of tree crop interaction in western Kenya and their tree management practices, if any, is essential.

Farmers in Central Kenya (Embu) manage trees very actively (Tyndall, 1996) but this seems to be restricted to a small area. Tree pruning is rarely practiced in western Kenya due to lack of knowledge, tradition, shortage of labour and fear of damage caused to trees. In order to be able to exploit the indigenous pruning practices by farmers, constraints to tree pruning and farmers views of various tree pruning practices adjacent to crops before and after pruning, it is essential to carry out socio-economics and biophysical studies of tree pruning concurrently. Consequently, farmers' problems and their indigenous knowledge in controlling those problems need to be assessed.

There are many important reasons that justify socio-economic survey. Some of the more common reasons are based on the need of AF scientist to use realistic research environments to test hypothesis and to investigate the performance of new systems in comparison with existing "indigenous" AF systems. Farmers possess invaluable knowledge about their indigenous AF systems, which can both lead to the identification of pertinent research questions and a shortening of the research process (Rusten, 1990). The success of any AF interventions ultimately depends on how well the research results are integrated with farmers' needs.

1.3.2 The need for tree pruning study

Competition, which can be defined as the negative effects of one species on another, can occur as trees cast shade and roots deplete soil moisture and nutrients. Above ground competition includes light and space, while below-ground competition includes water, nutrients and space (Ong *et al.*, 1996). Shading by the tree directly affects photosynthesis, transpiration and energy balance of the associated crops (Monteith and Unsworth, 1990). Below ground competition for soil moisture, nutrients and space has been identified by researchers as crucial especially where trees and crops are intercropped (Ong *et al.*, 1996).

Trees and crops compete for moisture and nutrients when grown in close proximity because most of their root systems are confined to the top 30-cm of the soil profile (Odhiambo, 1999). Numerous attempts to select for spatial complementarity in root distribution have been disappointing (Schroth, 1995; Odhiambo, 1999). Therefore,

root pruning has been suggested (Hocking and Islam, 1998; Wilson *et al.*, 1999). Root pruning is the cutting of lateral tree roots extending into adjacent crop. Cutting these roots has the potential to reduce competition between border trees and the crop for soil moisture and nutrients. Digging of open trenches between the trees and the fields reduces root competition and increase crop yields near the tree-crop interface. Crown pruning of trees is also assumed to reduce the amount of water that plant use, since it reduces the leaf area index. Both tree crown and root pruning on agriculture fields should, therefore, help increase soil moisture availability for utilization by crops.

Since trees and crops compete for the same resources, above and below-ground (Ong and Black, 1994), the question is whether we should exclude all trees from on-farms inter-plantings for fear of entwining root systems and shading effects of trees on crops. To answer this question we must address above and below-ground competition between trees and crops through tree management by crown and root pruning in order to minimize tree-crop competition.

Tree crown and root pruning offers mechanisms to enable farmers to manipulate trees' transpiration requirements, and zone of moisture extraction, thereby reducing competition with crops. It will also enable farmers to extend the life span of valuable trees once they have reached marketable size thus allowing them to retain "money in the bank" to meet their requirements for occasional capital expenditure. Reducing the extent of tree-crop competition, will enable farmers to maintain crop yields and

maximize benefits from tree products, and will enable tree planting to continue close to boundaries.

Diversified and increased farm outputs will help alleviate the chronic effects of poverty which are prevalent in drylands and should provide a positive feedback for tree planting leading to the expansion of more sustainable land use systems. Valuable timber trees can also be maintained alive and relatively un-competitive by heavy pruning and could be sold in times of need. Transpiration demand is determined by tree leaf area, which can be manipulated by crown pruning, and zone of water extraction could be manipulated by root pruning. If the availability of water is a major limitation to crop growth, it means that nutrient availability is also a limiting factor as water is the medium for making nutrients available to growing plants. Reduction in water use by trees is likely to result in substantial improvement in crop yield.

Adequate information about adaptability and behaviour of trees and agricultural crops in an intercropping situation is very necessary for good management. Unfortunately we know very little about the interactions between the trees and crops when trees are subject to crown and root pruning (Jones and Sinclair, 1996; Hocking *et al.*, 1997).

A tree pruning workshop organized by the Institute of Terrestrial Ecology and ICRAF in Uganda (Wilson *et al.*, 1999) discussed the needs for crown and root pruning in minimizing tree crop competition for light, nutrient, water and space.

Most of the end users, such as, women's group and individual farmers, observed the problems of growing trees with crops but did little to manage them. They all welcomed the idea of tree pruning and showed their willingness to test them. This shows that, there is an urgent need for the study of the value of crown and root pruning as a practical tool for farmers to manage tree-crop interactions through farmers' evaluation and field experiments.

The major goal of this study, therefore, was to assess the effect of crown and root pruning on tree survival, growth and to determine tree pruning practices that reduce competition of trees with crops. The value of crown and root pruning as practical tools for farmer management of tree-crop interactions was undertaken by direct measurement in two field experiments (Siaya and Nyabeda) in western Kenya and farmer perception of pruned trees.

Farmers' survey identified local tree pruning practices adopted by farmers and socio-economic factors influencing adoption. Field experiments which quantified soil water dynamics, light, tree water uptake combined with maize yield studies had permitted evaluation of competition by pruned and unpruned trees with adjacent maize crops. It also looked at pruning methodologies which control competition and knowledge of species tolerance to pruning. Crown pruning was also quantified in terms of range of utilizable products such as fuelwood and construction materials.

1.4 Objectives and hypothesis

1.4.1 Objectives

1.4.1.1 Overall objectives

To assess socio-economics of pruning boundary trees planted with crops as well as to evaluate the effect of crown and root pruning treatments on utilization of soil water, tree and maize growth and yield.

1.4.1.2 Specific objectives

- 1. To assess farmers' perceived competition effects of the trees on maize in boundary plantings and tree pruning practices to solve the problems.**
- 2. To identify the socio-economic factors affecting farmers practicing tree pruning in Siaya, western Kenya.**
- 3. To determine soil water dynamics in relation to the different tree pruning treatments.**
- 4. To assess the effect of tree crown and root pruning practices on tree and maize growth and yield.**

1.4.2 The alternative hypotheses

- 1. Crown and root pruning of trees reduces above and below-ground competition between trees and crops by improving use of soil water,**
- 2. Lateral root pruning of competitive tree species reduces water uptake from the zone exploited by crop root and promotes greater water uptake from deep soil, and**
- 3. Pruning can be used effectively by farmers to improve crop yield, gain valuable tree products, and reduce the likelihood of drought induced crop failure.**

CHAPTER TWO

2.0 LITERATURE REVIEW

This chapter presents a review of relevant studies carried out earlier on the topic of the present study. The needs for farmers' survey prior to any experiment in AF are reviewed in Section 2.1. Tree crop interactions for limiting resources in AF systems are reviewed in Section 2.2. A review of availability of soil water and water uptake by tree in boundary planting is presented in Sections 2.3 and 2.4 respectively while availability of light in boundary planting is reviewed in Section 2.5. Types of tree species used in this study are reviewed in Section 2.6.

2.1 Farmers' survey

2.1.1 Background

Farmers in developing countries have a long tradition of raising food crops, trees and animals together on the same land unit (Arnold and Dewees, 1997; Nair, 1991). Growing trees along with crops and livestock can enhance crop yields, reduce land degradation and improve recycling of nutrients, while producing fuelwood, fodder, fruits and timber (Sanchez, 1995).

Until recently, little attention was paid to this extensive but widely dispersed tree resource in the agricultural landscape. National agricultural services tended to be concerned only with those tree species, which have been domesticated and adopted

as agricultural crops. On the other hand, forest services focused only on trees within areas defined as forests. Falling between these two categories, most tree stocks maintained by farmers remained effectively ignored (Arnold and Dewees, 1997). Little effort has been made to implement the farmers' practices of growing trees and crops in their field.

In sub-Saharan Africa, agricultural technologies developed on research station led to spectacular yield increases in large scale commercial agriculture, but have generally not been adopted by small-scale farmers (Clarke, 1991). In the 1950s and 1960s, it was thought that education was all that was needed to improve the productivity of small-scale farms. Thus, efforts were concentrated on improving extension services. The 1970s and 1980s brought a change in approach based on the realization that these technologies were failing not because of lack of awareness on the part of small-scale farmers, but simply because the technologies developed on research stations were inappropriate (Clarke, 1991). Hence it is important that one looks at the socioeconomic factors of any technology being developed, its output and dissemination of this output to end-users.

2.1.2 Why socio-economic survey

Researchers view socio-economic survey as means of providing feedback from farmers to researchers. Trials in which farmers participated in all phases of the research process came closer to attaining the goal of farmer adoption of the technologies (Pinney, 1991; Franzel, 1992; Tyndall, 1996). Understanding the

dynamics of indigenous resource management system can potentially benefit natural development (Rusten, 1990). The survey results enable AF scientists to use realistic research environments to test hypothesis and to investigate the performance of new systems in comparison with existing “indigenous” AF systems. Farmers possess invaluable knowledge about their indigenous AF systems, which can both lead to the identification of pertinent research questions and shortening of the research process (Rusten, 1990). The success of any AF interventions ultimately depends on how well the research results are integrated with farmers' needs. Monitoring and evaluation of technology performance in AF projects may be approached from different angles: farmer evaluation and field testing (Scherr and Muller, 1990).

For the purpose of this study, a survey can identify tree pruning techniques, tools used in tree pruning and constraints in pruning trees. Simple pruning techniques and instruments which are normally identified by socioeconomic survey and which farmers are already using in their day to day farm activities need to be given first priority in any experimental setup. In this way we will be able to ensure that final recommendations do not require the injection of capital prior to implementation of results on farmers' field. Close involvement with farmers will also enhance the ownership of the result of the research by the end-users at the dissemination stage. Therefore, there was an urgent need for socioeconomic survey of tree plantings on farm in western Kenya, prior to the establishment of the tree pruning experiment in the area.

2.2 Tree-crop interaction

2.2.1 Background

In a historical review of AF, King (1987) noted that: 'throughout the world, at one period or another in its history, it has been the practice to cultivate trees and agricultural crops in intimate combinations. Although AF, defined in this seemingly simple but powerful way, has been practiced relatively recently by scientists and policy makers as a potentially useful approach to land management. Defining AF in one way or another has been a recurrent activity for many (Lundgren, 1982; see also various authors in: Stepller and Nair, 1987; Nair, 1989; Sanchez, 1995; Leakey, 1996).

Integration of trees into farmers' fields is termed as AF and was recently redefined as a dynamic, ecologically-based natural resource management system that through the integration of trees into farm-land and range-land, diversifies and sustains small holder production for increased social economic and environmental benefits (Leakey, 1996).

Agroforestry can be classified in two major groups: those which are sequential such as improved fallow, where crops are grown in fields previously improved by growing trees; and those that are simultaneous such as alley cropping, where crops are grown together with trees (Cooper *et al.*, 1996). However, it has been suggested that AF practices should be seen as stages in the development of an agro-ecosystem such that

the increasing integration of trees into land-use systems can be seen as the passage towards a mature agroforest of increasing ecological integrity (Leahey, 1996). Thus, the integration of various AF practices is like the formation of patches in an ecosystem, each of which is composed of many niches, and where the niches are occupied by different organisms making the system ecologically stable and biologically diverse (Leahey and Simon, 1997).

Several ecological factors may limit the extent to which specific AF systems can be adopted. Due to population pressure and decline in soil fertility within the humid tropics more people are moving into marginal semi-arid areas (Cooper *et al.*, 1996; Mungai, 1991), leading to changes in land-use and increased demand for tree products. Lack of affordable inputs and poor agricultural management of marginal land may result in widespread land degradation as more forests are cleared for agriculture, timber and fuelwood (Jackson *et al.*, 1995; Anderson, 1987). As a result, the soil and water resource base for food production is being degraded and essential sources of food, shelter, fodder, medicines and many other products are decreasing (Erskine, 1991; Harrison, 1987).

Inadequate and unreliable rainfall aggravates the situation because frequent crop failures and uncertainties in food availability necessitate that large areas of land be cleared for cultivation in order to provide adequate yields and food security. The long dry periods reduce tree growth rate and species diversity, and those few adopted species, which do survive, take longer to reach maturity. Thus a previous adequate

supply of mature tree products gradually decreases and increasingly young trees are harvested for timber and fuelwood.

Can a lesson from traditional land-use systems where farmers incorporated valuable trees into their farms help to develop sustainable AF systems? The success of AF in many parts of the tropics is particularly dependent on efficient use of the available soil resources including water. Arnold and Dewees (1997) argued that the use of trees as part of the farming system depends on two attributes: firstly, trees maintain and restore the physical environment needed to sustain crop production mainly through the restoration of soil fertility; secondly, tree products include those used directly by households such as food, fuel, construction materials, those used as inputs to agriculture such as fodder and mulches, and those used as raw materials for making agricultural implements. They also provide members of the household with income and employment. Other uses include establishment of trees to ensure tenure (to denote land ownership) and for cultural activities.

The product and service functions offered by trees underline the potential for AF to alleviate rural poverty (Sanchez, 1995). Benefits from trees can only be realized if losses due to competition between trees and crops are minimized and if trees offer high value products, which can compensate for crop losses due to competition.

It is argued that sustainability of AF systems is linked to high biological diversity of ecosystems and evidence exists that the introduction of trees into cropping systems could increase diversity of farm out-puts (Sanchez and Leakey, 1996). In their

examples, Sanchez and Leakey (1996) suggest that home gardens in Nigeria and the complex agroforests in Sumatra offer some of the best examples of how trees can be integrated into crop lands to increase land productivity on a sustainable basis. Increase in productivity has also been reported in the much less diverse traditional parkland systems with *Faidherbia albida* in West Africa (Sanchez and Leakey, 1996).

While some of the systems have been productive, reports of failures have also been cited mainly with hedgerow intercropping (Mathuva *et al.*, 1998; Rao *et al.*, 1991; Ong *et al.*, 1991 and Singh *et al.*, 1989). Some of these failures may be attributed to the use of AF technologies inappropriate to a particular ecosystem. Failure of hedgerow intercropping in some areas has been attributed to competition for water between the trees within the alleys and crops, which outweighs the benefits to site fertility improvement and dry-season production (Ong *et al.*, 1992; Mobbs *et al.*, 1998). The total water use by the combined tree and crop system may increase because both components use rain water during the cropping season and trees use stored water during the off season in the dry season (Ong *et al.*, 1996). However, the trees usually compete with the crops for water leading to crop yield losses relative to situations without trees.

Trees in cropland systems are categorized into three major systems, that is, scattered trees, boundary plantings, and intercropping with annual crops between widely spaced rows of trees (Rao, *et al.*, 1998). The degree of tree/crop interactions increases with increasing tree density, from low density in scattered trees systems to

high density in tree/crop intercropping systems. Scattered or dispersed trees in cropland, often known as “parklands”, are a widespread traditional practice in the semi-arid tropics, while boundary plantings and intercropping systems are commonly practiced throughout the tropics. In these systems trees are deliberately planted and managed for production of poles, timber, fruits, and/or fodder. Boundary planting involves planting of trees on farm and field boundaries, soil conservation structures such as on terrace risers.

Boundary or upper-story AF systems use widely spaced rows of trees such as *Populus deltoids* in northern India (Singh *et al.*, 1993; Singh *et al.*, 1998) or upper-storey trees such as *Cedrela odorata*, *Grevillea robusta*, *Albizia* species, *Markhamia lutea* found in East Africa (Hoekstra *et al.* 1991; Akyeampong *et al.*, 1995). They are usually associated with perennial (banana, coffee) and annual (bean, maize) crop fields.

Three distinct tree/crop interaction zones can be distinguished in boundary tree planting AF systems (Rao *et al.*, 1998). These are: 1) a zone of light and root competition, mostly under the tree crown, 2) a zone of root competition, some area beyond the tree crown, and 3) open cropped areas that are relatively free from the interference of the trees. The extent of the first two interaction zones depends on the tree species, climate and soil, and extends progressively over time with age and size of the tree. An understanding of these zones is essential for determining the optimum tree density and development of appropriate pruning regimes to maximize resource use and productivity of the system, and those relevant to this review, are soil water

relations and shading (light competition). Rao *et al.* (1998), argue that the exploitation of interactions between woody and non woody components is the key to the success of AF and that a better understanding of interactions is needed for improvement of traditional as well as newly evolving AF practices.

Rooting depths vary between tree species but most studies of fine root distribution have shown that fine roots are mostly found in the topsoil, which implies that trees are potentially competitive with crops. It is believed that trees with faster above ground growth rates have faster root growth rates and could be very competitive with crops (Rao *et al.*, 1993). For example, *Leuceana leucocephala* was more competitive with food crops because it was fast growing than *Senna siamea* or *Grevillea robusta*, which grew more slowly. In general it is believed that fast growing trees will use more resources than slow growing tree species. The effects of tree species on maize production, in relations to crown and root pruning needs to be investigated and hence the reasons for having 4 commercially valuable tree species in this study.

2.2.2 Competition and complementarity in Agroforestry systems

The exploitation of interactions between woody (tree/shrubs) and non-woody (annual crops) components is supposed to be the key to the success of all AF systems. Therefore, a better understanding of these interactions provides a strong scientific basis for the improvement of traditional as well as evolving AF systems. Recently, research on interactions in AF systems has received increasing attention and there have been various reviews on the topic. Anderson and Sinclair (1993) and Nair *et al.*

(1994) have given reviews from an ecological perspective, while Ong *et al.* (1996) reviewed the quantitative and physiological aspects of biophysical interactions in AF systems. Rao *et al.* (1998) gave a synthesis of the agronomic significant of biophysical interactions in the major AF systems, and stressed the importance of management implication of these interactions.

Plants depend on balanced and adequate availability of light, water, nutrients and space. When different plant species are grown together they share these resources, which often lead to differentiation, complementarity and competition (Buck, 1986; Michael, 1986). Differentiation is when each plant makes demand for a resource at different time and space, while complementarity is when one plant benefits from the other (Buck, 1986). Competition is the negative effect of one species on another (Campbell and Dawson, 1992). Competition occurs when different species require the growth resources in excess of the supply (Wear and Clement, 1980) or when one species has more access to a resource than another (Buck, 1986). Spatial complementarity occurs when mixed species are able to acquire environmental resources from different location at the same time (Anderson and Sinclair 1993). Temporal complementarity occurs when plants have different patterns of growth or life spans (Hooper, 1998) so that the periods of maximum demand for resources of different species are separated in time (Ahmed and Rao 1982). Temporal resource sharing concerns phenological mechanisms, and leads to enhanced productivity due to capture of more resources rather than changes in the efficiency of resource utilization (Willey *et al.*, 1986; Ong and Black 1994).

One of the most promising AF technologies that can help reduce land degradation while at the same time reducing pressure on indigenous forests in the tropics is boundary tree planting. Boundary planting is a part of an AF system in which trees are grown along agricultural fields or boundaries with food crops. Besides providing wood production for the household needs, field and border trees are effective tools in reducing wind borne soil erosion and protecting crops from wind damages. Border trees improve crop yields and water use efficiency by altering the micro-environment by reducing wind speed and minimizing climatic stress factor (Frank *et al.*, 1974; Rosenberg, 1974). With wind protection, grain yield of crops increased during years of normal or below normal precipitation (Ferber *et al.*, 1955; Staple and Rehane, 1955; Stoeckelcr, 1962; Read, 1964; Radke and Burrows, 1970; Frank *et al.*, 1974; Ogbuehi *et al.*, 1982 and Brandle *et al.*, 1984).

Above ground competition includes light and space, while below ground competition includes water, nutrients and space (Etherington, 1975). Shading of crops by trees directly affects photosynthesis, transpiration and energy balance of the associated crops (Rosenberg *et al.*, 1983). Some advantages of shade include soil temperature reduction during crop germination and establishment in hot climates (Vandenbeldt *et al.*, 1990) and reduction of evapo-transpiration of shaded crops (Beer, 1987). However in semi arid conditions the transpiration of trees may increase water stress of associated crops (Nair, 1993).

Below-ground interactions between trees and crops can also be positive or negative. Positive interactions involve, nitrogen fixation, improvement of soil physical conditions, addition of organic matter from turnover and mobilization of nutrients from sub-soils to surface soil for use by shallow rooted crops (Sanchez, 1987; Campbell and Dawson, 1992). Negative interactions involve competition between trees and crops for moisture, nutrients and space. When trees and crops are grown together, rooting densities increase and inter-root distances decrease, thereby increasing competition (Bohm, 1979, Young, 1989, 1997; Gillespie, 1989). Root excavation studies indicate that an extensive and dense spread of tree roots results in serious competition with crops (Ong *et al.*, 1992).

2.2.2.1 Capture of growth resources

Above ground competition for light and below-ground competition for water are both important under boundary tree plantings, as was demonstrated in a study in Uganda that used a rift mesh to prevent lateral spread of roots (Okorio *et al.*, 1994). Without the root mesh, crop yields adjacent to the tree ranged from 20-55% of yields in the treeless plots. When the root mesh was installed to 0.5-m depth and 0.5-m away from trees, yields increased by 16-152%. However, the presence of the root mesh did not restore crop yields to open area levels, suggesting the existence of above ground competition for light.

Another study in Burundi also using a root mesh, found below-ground competition between beans on the one hand and bananas and *G. robusta* on the other, to be more

important than competition for light in a multi-strata AF system (Akyeampong *et al.*, 1999). Aboveground competition for light can be reduced by side pruning of branches (Kessler, 1992), while below ground competition for water by periodic root pruning either by deep ploughing or by use of axes and hoes (Roger and Rao, 1990; Rao *et al.*, 1990; van Roodc, 1992).

Competition may be more severe between similar species than between species with contrasting growth habits (van Demeer, 1989). However, the opportunity for complementarity of resource use between species is restricted by the fact that all plants are competing for the same finite resource of light, water, CO₂ and nutrients. Thus, there is extensive overlap between species in their resource requirements. Various works (Van DenBeldt *et al.*, 1990; Ong *et al.*, 1991a; Monteith *et al.*, 1991; Ong and Black, 1996) have reviewed competition in plants in relation to AF.

The component of AF systems often differ greatly in size, with the result that the growth of the smaller under-story species may be inhibited by shading, and possibly also by competition for water and nutrients. Competition for light can be the primary limitation when water and nutrients are freely available. However, in many tropical systems, water or nutrient availability rather than light is the major limiting factor (Ong *et al.*, 1991b).

When resources are not limiting, densely planted monocultures usually provide the most efficient resource capture system. However, where one (or more) resource (s) is (are) limiting, it may be possible to improve productivity by using species mixtures.

This is because the component species capture more of the available resources or use them more efficiently for growth than monocultures. In such instances, mixtures may provide a greater yield than the combined yield of the corresponding sole crops (Ofori and Stern, 1987).

Research on competitive interaction in AF systems has tended to concentrate on establishing the relative importance of above ground and below-ground competition for resources (Synadon and Harris 1981; Corlett *et al.*, 1992a, b) and on complementarity or resource sharing (Ong and Black 1994). Determining the relative importance of above ground and below ground interactions is difficult (Donald 1958), although methods such as root separation have been applied in some studies (Marshall and Willey 1983; Singh *et al.*, 1989; Okorio *et al.*, 1994; Chirko *et al.*, 1996b).

2.2.2.2 Concepts of resource capture

The concept of complementarity in the use of resources is central to the assumption that mixtures of trees and crop species may lead to increased productivity in AF (Ong and Black 1994). Complementarity in resource use in AF systems occurs when trees acquire resources of water, light and nutrients that crops can not acquire (Cannell *et al.*, 1996). Complementarity must also lead to more efficient conservation of resources, such that total productivity increases (Ong *et al.*, 1996; Hagger and Ewel 1997; Hooper 1998).

The potential for complementarity in AF has largely been based on the assumption that benefits occur when grain legumes are grown in mixtures with cereal crops (Willey 1979). However, in AF, trees have a network of fine roots in the soil at the time the crop is planted giving the trees an advantage in soil water and nutrient uptake (van Noordwijk *et al.*, 1996). Depending on the tree species, environment, age and management, tree competition may limit the potential for complementarity of resource use in AF.

Agroforestry species may use resources in a complementarity manner between AF components (Ong, 1995). Such complementarity describes positive associations of species that result in increased system of productivity (Hooper, 1998). Cannel *et al.* (1996) state simply that complementarity in resource use in an AF system occurs when trees acquire resources that crops could not acquire and that available resources must be used efficiently such that total productivity increases. This implies that complementarity may be manifested by either increased resource or improved resource use.

Crop yields in semiarid tropics may often be low due to competition for water between the crops and the trees in AF systems. However, the use of trees with complementarity in water use with crops can minimize competition for water between the trees and the crops. The concept of complementarity in the use of resources is central to the assumption that mixtures of tree and crop species may lead to increased productivity in AF (Hooper, 1998; Ong and Black, 1994). Results from semiarid tropics have shown that AF systems are not always productive since low

crop yields have sometimes occurred when trees were introduced into croplands (Rao *et al.*, 1997). Established trees network of fine roots in the soil at the time the crop is planted give the trees a possible advantage in soil water and nutrient uptake (Ong *et al.*, 1996). Depending on the tree species, environment, age and management, tree root competition may limit the potential for complementarity of water use in AF.

2.2.2.3 Effects of trees on crop yield in tropics boundary planting

While appreciating the fact that complementarity has the potential to improve productivity in AF systems as whole, recent studies (Odhiambo, 1999) highlight the fact that trees can out compete crops for soil water and nutrients leading to greatly reduced crop yields in overall system. The effect of boundary trees on crop yields, therefore, depends on the site and age of trees. Malik and Sharma (1990) found that 3.5 year-old *Eucalyptus tereticornis* on field boundaries reduced crop yields by 41% up to 10 m from the tree row.

Similarly, crop yield losses were observed 2 years after tree establishment, with different tree species showing different patterns of competition depending on growth rates and rooting patterns (ICRAF 1996). The fast growing *Grevillea robusta* and the slow growing *Croton megalocarpus* depressed crop yields only over a short distance (<3 m). Although *Senna spectabilis* had faster height growth than the other tree species, it depressed yields least, probably because of its limited canopy and deeper rooting system.

Tree species and distance from tree line significantly affected the yield of wheat interplanted with *Eucalyptus grandis*, *Grewia optiva* and *Morus alba* (Khybri *et al.*, 1992). The trees were planted in lines in a north-south orientation and were spaced 5 m between individual trees. *Eucalyptus grandis* had the greatest depressing effect on wheat yields, and as the age of the trees increased, the effect also increased from 4% in the first year to 61% in the ninth year. Corresponding values for *Grewia* and *Morus* were 5% to 52% and 13% to 58% respectively.

Wheat yields at various distances from the tree lines showed the lowest values within 1 m (Table 2.1). Wheat yields decreases were 49% for 1m, 33% for 1-2 m, 26% for 2-3 m and 16% for 3-5 m distances from the tree lines. As the distance from the trees increased, the shading effect decreased.

Large differences among species for competitiveness were also observed 3 years after tree establishment on field boundaries in Uganda (Okorio *et al.*, 1994). Over 3 to 4 m from the tree row, crops yield reduction ranged from 60% adjacent to the fast growing *Maesopsis eminii*, to 38% in the slow growing *Markhamia lutea*. It appears that trees become competitive with age and increased size.

Table 2.1: Summaries of wheat yield decreases by distance from tree lines in western Himallia, India.

Distance (meters)	Yield reduction (%)
1-m	49
1-2-m	33
2-3-m	26
3-5-m	16

Crop yields under tree in boundary planting may be unaffected during the early years of tree growth, but could increase or decrease when the trees grow large, depending on the tree species. Any positive influence of trees on crop yields would not be expected for many years (Poschen, 1986; Rhodes, 1997). However, fast growing trees such as *Eucalyptus* species, *Cordia abyssinica* and *Maesopsis eminii* reduce crop yields a few years after their establishment (Ralhan *et al.*, 1992; Okorio *et al.*, 1994; Akycampong *et al.*, 1995).

Competition for light in boundary planting AF systems is unlikely when lopping for livestock feeding is practiced (Tejwani, 1994), or where trees drop their leaves during the rainy season when crops are grown (Vandenbeldt and Williams, 1992). However, shade can be a major problem under large, unmanaged, and/or evergreen trees (Kessler, 1992; Jonsson *et al.*, 1999). In such cases, as little as 20% of incoming photosynthetically active radiation (PAR) reaches the under-story crops thereby affecting their growth and productivity (Tables 2.2 and 2.3).

Table 2.2: Summaries of effects of boundary planted trees on adjacent crops in the tropics (Percent reduction in PAR reaching crops).

Reference	Country	Species	Age (years)	PAR reduction (%)
Daniel et al., 1991	Kenya	<i>Cajanus cajan</i>	2	46-57
Miah et al., 1995	Philippines	<i>Acacia auriculiformis</i>	2.5	53
		<i>Acacia mangium</i>		55
		<i>Gliricidia sepium</i>		59
Okorio et al., 1994	Uganda	<i>Alnus acuminata</i>	3	25
		<i>Casuarina</i>	3	59
		<i>equisetifolia</i>		
		<i>Grevillea robusta</i>	3	33
		<i>Markhamia lutea</i>	3	49
		<i>Maesopsis eminii</i>	3	58
Newman et al., 1998	China	<i>Paulownia trees</i>	8	45 80
Sskabembe et al., 1997		<i>Robinia pseudoacacia</i>	2	25

% reduction is comparisons of plots with and without tree plots.

In short term AF experiments in Uganda, a wide range of competitiveness was also found, ranging from positive interactions between trees and crops (*Alnus acuminata*) to extremely negative (60% loss in crop yield with *Maesopsis eminii*). Although differences in root system architecture occur, it is clear from studies at Machakos (Howard *et al.*, 1997) that root systems of the majority of tree species rapidly form extensive networks and extract water from the crop rooting zone, creating substantial tree-crop competition when moisture content below crop rooting zone is very low, 12-45 mm (Wilson *et al.*, 1999).

Table 2.3: Summaries of effects of boundary planted trees on adjacent crops in the tropics (percent reduction in crop yields).

Reference	Country	Species	Age (years)	Crop reduction (%)
Akyeampong et al., 1995	Burundi	<i>Maesopsis eminii</i>	2	12
Howard et al., 1997	Kenya	<i>Grevillea robusta</i>	4	30
Newman et al., 1998	China	Paulownia trees	5	63
Malik and Sharma (1999)	India	<i>Eucalyptus tereticornis</i>	3.5	41
Khybri et al., 1992	India	<i>Eucalyptus species</i>	1	4
			9	61
		<i>Grewia optiva</i>	1	5
			9	52
		<i>Morus alba</i>	1	13
			9	58
Corlett et al., 1992b	Kenya	<i>Leuceana leucocephala</i>	5	77
ICRAF, 1996	Kenya	<i>Grevillea robusta</i>	2	25
Okorio et al., 1994	Uganda	<i>Alnus acuminata</i>	3	23
		<i>Casuarina equisetifolia</i>	3	31
		<i>Grevillea robusta</i>	3	29
		<i>Markhamia lutea</i>	3	59
		<i>Maesopsis eminii</i>	3	31

% reduction is comparisons of plots with and without tree plots.

Many researchers are currently investigating the processes by which AF systems can be sustained, adopting modelling approaches such as those outlined by Lawson *et al.* (1995) to determine the factors limiting the success of such systems in the field. The hydrological reasons for the success or failure of intercropping trees and crops in AF systems are still largely unknown (Wallace *et al.*, 1995).

2.2.2.4 Tree pruning in boundary planting

Since quantitative investigations of water-use in AF systems are rare (Ong *et al.*, 1991), Jackson *et al.* (1999) suggested the use of management practices such as canopy pruning or root pruning, by trenching, in imposing complementarity on AF systems. He further reported how rainfall distribution was modified by both tree and crop canopies in AF systems. In addition, he also demonstrated how these processes could be controlled by regular manipulation of the tree canopy through pruning. Tree crown pruning would reduce shade, water loss through evapotranspiration and will limit zone of extraction of water (Wilson *et al.*, 1999)

Experience with alley cropping has shown that few farmers can afford the high labour demand required for regular pruning simply to reduce competition of fast growing trees (Cooper *et al.*, 1996). Yet, a recent survey of farmers' tree pruning practices in the highlands of Kenya has revealed a surprising range of local pruning practices (Tyndall, 1996). In Bangladesh, farmers adopted root pruning very quickly. The surface lateral roots of trees are pruned annually at a distance of about 1 to 2 m from the stem and the task is quite easily accomplished (Hocking and Islam, 1998).

Root pruning is the cutting of lateral tree roots extending into adjacent crop and cutting these roots has the potential to reduce competition between border trees and the crop for moisture and nutrients (Steven and Charles, 1990). Digging of open trenches between the trees and the fields reduces root competition and increase crop yields near the tree-crop interface (Singh, 1987; Onyewout *et al.*, 1994). An interesting aspect of root trenching might be that it forces tree roots into deeper soil layers (Ong and Khan, 1993; Wilson *et al.*, 1999). Crown pruning of trees, a common procedure in many associations, reduces competition with crops by reducing transpiration (Ong, 1995).

2.3 Soil water

Water is an essential component of plant life. It comprises approximately 70 to 90 % of the total fresh weight in physiologically active plants (Hsiao, 1973). Almost any parameter of crop growth is modified by water deficits provided that stress is severe and sustained (Stirling, 1988). Soil water stress leads to decrease in transpiration from plant canopies through stomatal closure (Acevedo, *et al.*, 1971). As the soil dries, the soil water potential and soil hydraulic conductivity decrease. It becomes more difficult for plants to extract water; consequently cell turgor pressure decreases, leaf expansion decreases, leaves wilt, and canopy duration is reduced, reducing light interception and photosynthesis (Hsiao, 1973). Stomatal control of transpiration can reduce rate of soil drying. Trees with more sensitive stomatal response to vapour pressure deficits are adapted to water limited environments and could be the most suitable choice when grown in mixtures with annual crops.

Soil water is one of the major below-ground resources required for plant survival. Water plays an important role in many soil chemical reactions, the movement of solutes, the redistribution of air and weakening of the soil matrix, to facilitate root growth (Russell 1988). In many tropical farming systems, plants survive for part of their growing cycle on stored soil moisture (Russell 1988), which is recharged by seasonal rainfall, and to a small extent by inter-layer soil moisture transfer. Vertical moisture distribution in the soil profile after rainfall content varies with infiltration, soil surface evaporation and plant activity while horizontal redistribution is mainly due to plant root activity (Pidgeon 1972).

Movement of water in soils is caused by differences in soil water potential or gradients due to gravity, solute concentration, temperature, surface tension and fundamentally by plant root activity. Root water uptake is substantially faster than inter-layer water flow and contributes greatly to soil water distribution within the soil. Loss of water into the atmosphere through evapotranspiration involves transfer of liquid water to vapour (Russell 1988). Potential evaporation rates can reach 8-10 mm/day in semi-arid areas (Messing *et al.*, 1998).

Movement of water due to soil surface evaporation slows down substantially when the surface 1 to 2 mm depth dries because then water vapour has to diffuse through pore spaces at low concentration gradients before it reaches the atmosphere (Penman and Schofield 1941). Water can also flow against capillarity movement or gravity in deeper horizons when it moves from deeper soil layers to recharge the root horizon, which gets continually drained as the season progresses (Thorburn *et al.*, 1993).

Though it does not provide information about water availability to plants, soil water content expressed in terms of volume or weight per unit of soil is less ambiguous than soil water potential. The most direct method of determining soil moisture content is on a gravimetric basis, involving determination of soil weight loss after oven-drying for 24 hours at 100-110 °C. This is expressed as a percentage of oven-dry weight of soil (w/w%). Volumetric soil water content can be determined by multiplying the gravimetric soil moisture content by its bulk density, assuming the soil does not swell or shrink.

Non-destructive methods of determining soil water content include the time domain reflectometry and the more commonly used neutron probe. Volumetric soil water can be determined by non-destructively using a neutron probe through a count of neutrons slowed down by nuclei of hydrogen atoms, mostly on water molecules within a sphere of 30-40 cm diameter in the bulk soil (London, 1991). The count of slow neutrons is proportional to the amount of hydrogen atoms in the soil and therefore to water content. A calibration is necessary. The neutron probe is not able to detect sharp soil moisture differences as occur across a wetting front. Also, it is not reliable for measuring soil surface water due to escape of neutrons in the air and inclusion in the counts of organically bound hydrogen in form of root litter (Eeles, 1969).

Other methods available for measuring soil water potential include tensiometers, thermocouple hygrometers, thermocouple psychrometers, gypsum blocks, filter paper, and pressure plates. Some of these methods that can be used in the field are not designed to cater for dry soil condition common in the tropics. Thermocouple hygrometers can measure arid-soil water potentials, but they are prone to errors from thermal gradients. Even so, the accuracy of most methods available for determining water potential is more than sufficient for agronomic purposes (Savage *et al.*, 1992).

The filter paper method is economical and yields accurate water potential measurements assuming that the environment into which the filter paper is placed is at the same total water potential as the medium. Soil water potential is inferred from the pre-determined retentivity of the filter paper with which it is in equilibrium (Savage *et al.*, 1992). Measuring soil water potential is beyond the scope of this study, however, overall summary of review is given for better understanding of the process of water uptake by plants or water movements in plants.

In summary, a mixture of methods measuring both soil water content and soil water potential is necessary if plant-soil interactions are to be understood. Measuring both soil water potential and soil moisture content may be necessary, given the limitations of using either alone. Water uptake by plants is influenced by the hydraulic conductivity, nature of the soil and the plant's ability to extract it. This varies with species as well as the stage of plant growth. In a mixed plant system, this is modified further by the activity of associated plants.

2.4 Sap flow

2.4.1 Water uptake by trees

Plants require water for photosynthesis of sugar, maintenance of cell turgidity, transport of soluble material and as a solvent of cell biochemical reactions. These requirements only constitute 1% of the water taken by the plants, most being transpired through open leaf stomata (Larcher, 1975; Comstock and Ehleringer, 1993) and to small extent by flower parts and pods e.g. 15% of total transpiration in rice (Batchelor and Roberts, 1983).

Transpiration and gas exchange are closely related because they occur when stomata are open (Swanson, 1984). When leaf stomata open to allow entry of CO₂ into the chloroplasts, water is lost. Air in leaf intercellular spaces is always near saturation even in drought-stressed plants (Ong *et al.*, 1996), therefore loss of water from open stomata depends on the vapour pressure gradient between the atmosphere and the intercellular spaces.

Water uptake from the soil into the plant is driven by a series of closely linked potential differences between the bulk soil, the root xylem, transpiring leaves and the atmosphere. Stem water content rarely changes except in severe drought (Jarvis, 1975).

Similarly, leaf water potential varies only within a narrow band (conservatism of leaf water potential), which corresponds to a wide range of water inflow rates in the roots (Hailey *et al.*, 1973). When soil water is low, atmospheric conditions govern transient leaf and root water potentials. Leaves can control their potential by reducing their conductance by curling wilting or closing their stomata, thus enabling plants to withstand soil and atmospheric moisture deficit (Simmonds and Kuruppuarachchi, 1995).

Overall plant transpiration is controlled by the total transpiring leaf area rather than individual leaf conductance (e.g., groundnuts, Black *et al.*, 1985). Leaf water potential becomes more negative with increasing height within the canopy due to difference in irradiance, low conducting ability of juvenile leaves at the shoot tips or the accumulation of xylem resistances as the hydraulic path length increases (Weatherley, 1979).

The flow of water from the soil matrix towards the root is driven by potential difference between xylem sap, and to a lesser extent, by high solute potential between the root stele, and the soil solution at the root surface (Baker, 1984). At high transpiration rates, steep gradients of soil water potential develop dynamically around individual roots. When transpiration rates are decreased, leaf water potential can recover completely, disguising soil moisture stress levels within the overall soil profile, due to perirhizal equilibration as soil water at the root surface is refurbished to near capacity levels (Weatherley, 1979).

Within a transpiring tree, the water potential is maintained between 0.01 and 0.05 Mpa m^{-1} , modified occasionally by change in the atmosphere and the leaf response to it (Baker, 1984). This within plant resistance to transpiration may facilitate conservative water use and act as buffer to protect leaves from very negative soil water potentials by allowing of vessels from stem storage (Passioura, 1988).

Transpiration is also hindered by a series of other resistances within the bulk of the soil but resistance at the soil-root interface is assumed to be negligible at field capacity, hence the major hydraulic resistance is that within the plant. As the soil drains, resistance at the root interface accounts for almost 65% of resistance to water flow, and is quite conservative despite differences in relative shoot: root sizes (Weatherley, 1979).

Various reasons have been given to explain this interfacial resistance. While in root cortical cells, water is mainly transported apoplastically and to a lesser extent through symplastic and vacuole to vacuole transfer (Baker, 1984), at the endodermis, only symplastic transport is possible because of the suberised Casparian strip (Passioura, 1988). This may account for some of the resistance to water entry into roots. Alternatively, intimate coupling of roots with soil matrix may be lost when soils become too dry, creating gaps that break the continuous cohesive flow of water (Weatherley, 1979).

In sandy soil, this occurs when soil moisture drops to 25% of that at saturation levels (Simmonds and Kurupparachchi, 1995). Decoupling occurs at individual root level,

especially when soil is dried rapidly (Weatherley, 1979). Another cause of root-soil interface resistance may be the accumulation of solute at the root surface, if their projection towards the root is faster than their upward transport into the stem creating a barrier with negative potential between the soil matrix and the root xylem (Passioura, 1981). The solute effect is transient and may, over time, most substantially affect water inflow especially in moist soils (Passioura, 1981).

Most water uptake within roots occurs radially, which is also the direction in which most resistance is encountered. Resistance to axial water uptake by roots is low in dicotyledonous plants, but is quite substantial in Poaceae, which have small vascular systems (Wilson *et al.*, 1976). Resistance to axial flow is mainly due to resistance by individual vessel walls, following Poiseuille's law in smooth vessels such as those in Poaceae (Greacen *et al.*, 1976). In dicotyledonous plants, vessel walls are perforated with pits and Poiseuille's law may underestimate their resistance (Jeje and Zimmermann, 1979). Taylor and Klepper (1978) showed that axial xylem resistance can significantly affect moisture in the soil layer from which water is exploited. Resistance to flow is inversely proportional to root length (Weatherley, 1979).

Water uptake by roots depends on their size, health and location in the soil matrix. Roots smaller than 2 mm diameter (fine roots) take up water all along their lengths, though the maximum uptake occurs just behind the root tip where xylem vessels have developed and suberisation of the endodermis has not yet taken place (Russell, 1988). Taproots have greater water conductance per unit suction than other forms because they contain more xylem (MacFall *et al.*, 1991; Dawson and Pate, 1996).

Plant health or soil conditions that affect live root cell functions directly affect water uptake. Drew *et al.* (1989) and He *et al.* (1992) observed a reduction in root hydraulic conductivity of nitrogen or phosphate starved *Zea mays* due to an increase in formation of aerenchymatous tissue, which had a discontinuous cell wall network. Diseased root of lupin also tended to lose their conductance (Grose and Hainsworth, 1992).

The rate of inflow may be also affected by root age, hence increasing acropetally (Russell, 1988). Younger roots extract water more rapidly from soils, creating regions of low water potential, hence low soil hydraulic conductivity (Simmonds and Kuruppuarachchi, 1995). In multistorey systems, crop roots normally grow within depletion zones of tree roots. Likewise, root branches grow in the depletion zones of the primary axis, thus they operate at lower water gradients and have a lower capacity to extract water than roots of the same characteristics growing in virgin soil (Robinson, 1994).

Overall water use of the plant is governed by the root: shoot ratio (Russell, 1988). That is why cereal crops, which stop growing their root system after flowering, leave residual water in the deep soil system after harvest (Hurd, 1974) than certain grasses with an extensive root system compared to shoot size (Willatt, 1971). With adequate water supply, maximum transpiration is proportional to root density. Resistance to flow or water within the root system does not vary between species and depends on the rate of inflow (Passioura, 1981).

If soil water potential is averaged over the whole profile, it may seem that water uptake is occurring at very low soil water potentials when in fact uptake is restricted to only a few roots with a less negative potential while the ones in the dry (surface) portion of the soil have become non-functional. When this occurs, the root xylem potential is high compared to that of the soil in the wetter portion causing inflow to increase as radial root resistance decreases (Weatherley, 1979). Thus, at negative soil water potentials, root extent and soil water uptake are not related (Cook and Dent, 1990).

2.4.2 Sap flow in plants

Sap flow, or water movement in a plant occurs when atmospheric evaporative demand at the leaf surfaces causes water potential gradients to occur within the plant and between its root and the soil. At a given stem water content, sap flow is closely related to transpiration, but lags slightly behind it. Schulze *et al.* (1985) observed a 90 minute lag between sap flow and transpiration measured using cuvettes on *Larix decidua* and *Picea abies*.

2.4.3 Application of sap flow techniques

Measuring sap flow on individual stems and scaling up to stand level is direct way of measuring plant water use compared to use of micro meteorological data. Sap flow measurement is most appropriate in regions where transpiration rates are low compared to the atmospheric demand (Hatton *et al.*, 1995), which is usually the case if soil water is limited. Methods available for determining sap-flow on individual

stems involve use of heat transfer and they include the heat balance, the steady-state balance and the heat pulse.

Stem heat balance (SHB) method

The SHB method involves supplying a volume of stem with a known amount of heat, using a heater wound or wrapped around a section of the stem (Sakutarani, 1981). Thermocouples are used to measure heater temperature and sap temperature on entering and on leaving the heat section. From the heat balance within the stem, the heat transported by moving sap, Q_r , is calculated as:

$$Q_r = C_w F (T_d - T_u) \dots\dots\dots \text{(Equation 2.1)}$$

Where, C_w is the specific heat capacity of sap (or water), F is mass of the flow rate of water, and $T_d - T_u$ is the temperature difference between water entering and that leaving the heated stem segment. Because of its external installation, SHB is more complex to set up properly in experiments (Shackel *et al.*, 1992). The weakness in the SHB theory results from assumed values of thermal conductivity of the stem and the insulating material (Baker and Niebler, 1989). The method is also prone to errors from destabilization from rapid warming of air at sunrise or after a period of cloudiness (Steinberg, 1988). Nevertheless, SHB measurements have high absolute precision (Baker and van Bavel, 1987).

Steady-state temperature method (SST)

Sap flow can also be measured through supplying heat to the stem to maintain a constant temperature by varying power input rather than in pulses. This called the steady-state method. An example is the Granier gauge (1985, 1987), where two metal probes are inserted into the wood. Sap flow is derived as a function of rate of heat loss from a heater in comparison to the ambient sap temperature recorded by a second sensor far upstream on the stem. Here, sap velocity is calculated as:

$$U = [\delta T(0) / \delta T(U) - 1/a]^{1/b} \dots\dots\dots \text{(Equation 2.2)}$$

Where $\delta T(0)$ and $\delta T(U)$ are temperature differences at zero velocity and at sap velocity U , respectively; $a = 0.0206$ and $b = 0.8124$ (Granier, 1987). Values of (a) and (b) are not species sensitive, making the method more suitable than the SHB for measuring sap flux in large stems.

Heat pulse velocity methods (HPV)

Heat pulse velocity (HPV) measurements involve determination of sap flux within the whole trunk by integrating various point measurements within conducting wood. HPV measurements are based on the assumption that wood is thermally homogeneous, vessels conduct sap at uniform velocity, and that interstitial space between vessels are small enough to allow transverse heat transfer to occur between moving sap and stationary wood in negligible time (Marshall, 1958).

Swanson (1981) found that interstitial distance larger than 0.4 mm were enough to cause wood thermal inhomogeneity. Heat transfer calculation can be based on maximum temperature or temperature equilibration between two sensing points. In the former method (Equation 2.3), HPV is computed from the time, t_m , it takes a single sensor at a known distance downstream from the heater to reach maximum temperature (Erickson, *et al.*, 1986; Cohen *et al.*, 1988).

$$V = (x^2 - 4kt_m) / t_m \dots\dots\dots \text{(Equation 2.3)}$$

Where V is the heat velocity, x is the distance between the heater and the sensor, and k is the thermal diffusivity of the wood (Cohen *et al.*, 1981). When sap flow is high, t_m is definite, but with lower rates, the heat peak is less definite and takes longer to detect, thus lengthening the interval between individual measurements (Grime, 1992).

The equilibration technique on the other hand, is based on the fact that the temperature wave is symmetrical along the stem axis. Thus, if equal temperature is detected at two points up-and down-stream of the heater, then the peak has travelled to a distance half way between the two sensors (Swanson and Whitfield, 1981). It is calculated as:

$$V = (x_d - x_u) / 2t_0 \dots\dots\dots \text{(Equation 2.4)}$$

Where x_d and x_u are distances of the downstream and upstream sensors from the heater, and t_0 is the equilibration time. The construction material of sensor probes and the heater have negligible influence on heat transfer (Swanson and Whitefield, 1981). This method is favoured because the only measured value is the time of equilibration. No restricted spacing is recommended, but t_u (time of upstream from the heater) is usually less than t_d (time of downstream from the heater) Measurements from widely spaced sensors are not as accurate as those from close ones, but they are more reproducible (Cohen *et al.*, 1988, 1993).

Marsahl (1958) converts heat velocity to sap velocity using Equation 2.5.

$$V_s = V_h (P_{sm} C_{sm}) / (P_s C_s) \dots\dots\dots \text{(Equation 2.5)}$$

Where V_s is heat velocity, P_s , C_s are density and specific heat capacity of sap (assumed to be equal to heat of water), and P_{sm} and C_{sm} are density and specific heat capacity of green wood.

The density and heat capacity of green wood is obtained by determining moisture content, volume (W_i) and oven – dry weight (W_d) of wood (equations 2.6-2.9). Then heat capacity and density of green wood are computed as the sum of the proportion of each multiplied by its heat capacity or density respectively (Edwards and Warwick, 1984).

$$F_l = (W_r - W_d) / W_d \dots\dots\dots \text{(Equation 2.6)}$$

$$F_m = W_d / (1.53 W_i) \dots\dots\dots \text{(Equation 2.7)}$$

$$P_{sm} = (1530 F_m + 1000 F_l) \text{ kg/m}^3 \dots\dots\dots \text{(Equation 2.8)}$$

$$C_{sm} = ((1.53 F_m C_m) + (C_s F_l)) / (F_l + 1.53 F_m) \text{ KJ/kg}^{\circ}\text{C} \dots\dots\dots \text{(Equation 2.9)}$$

Where,

W_r and W_d are weight of green and oven dry wood respectively

W_i is volume of wood sample

F_l and F_m are volumetric fraction of water and the wood matrix respectively.

Limitations of Heat Pulse Velocity Methods

The heat pulse velocity method was used in the current study. Therefore, literature on its utility is reviewed in more detail here. Since embedding of heat sensors into the stem tissue causes damage to its vessels, it modifies its conductivity (Zimmermann, 1983). This can be accounted for by measuring the wounding extent (Swanson and Whitefield, 1981).

Wound effects can be observed by tyloses bud initiation, which demonstrated a loss of vessel water conductance (Zimmermann, 1983). Tyloses buds appearing close to the probe insertion points can be assumed to be caused by wounding, though sometimes drought may cause the same effects (Tyree and Ewers, 1991; Moore, 1993).

Wound diameters can be determined by measuring those areas of the stem cross sections that are not stained when cut trees are made to absorb dyed water (Olbrich, 1991). Wound diameter increases with time, but may stabilize at a given day (Hatton *et al.*, 1995) while in *Pinus* species wound diameter remained stable for 10-20 days (Swanson and Whitefield, 1981), and up to 27 days in *Eucalyptus marginata* (Marshall, 1993). Wounding can be avoided by using heaters wrapped around stems (Heine and Farr, 1976). This is most desirable for small stems, but it can overheat the xylem bearing the heater (Stone and Shirazi, 1975).

Measuring sap flow by heat pulse methods requires precision in temperature determination in a situation prone to noise from ambient conditions as well as physiological growth processes and sometimes microbial activity (Swanson, 1984). Such points of measurements on individual stems are prone to more error than is generated when scaling readings up to homogeneous stand levels using stem diameter or canopy size (Hatton *et al.*, 1995).

Linear relationships between transpiration and leaf area are only good when soil water is not limiting (Greenwood *et al.*, 1992). Linear relationships between conducting wood diameter or stem diameter and transpiration were found to be more consistent (Hatton *et al.*, 1995).

Even within the same trunk, sap flux density varies at different loci in the conducting wood depending on previous climatic conditions (Miller *et al.*, 1980; Olbrich, 1991). When integrating point measurements to whole stem sap flux, fitting a polynomial to

sap flow velocity at different depths into the stem is prone to artefact (Edwards and Warwick, 1984).

Errors from using heat pulse methods accumulates from several empirical equations. therefore, calibration is necessary especially if used on species that are not thermally homogeneous. The accuracy of the heat pulse method with the compensation technique varies with tree species when tested against the gravimetric transpiration of the cut tree.

High accuracy was obtained with *Eucalyptus grandis* (Olbrich, 1991) and *Eucalyptus Magnifera* Mudie (Moore, 1993), but as much as 62% underestimation was observed in *Eucalyptus largiflorens* during drought (Streeter, 1993). Granier *et al.* (1996) found that sap flux density from the heat pulse was in agreement with that from other methods for flows of more than 0.5 cmh^{-1} in various species.

Stem capacity contributes up to 25% of total daily transpiration (Morikawa, 1972). If this contribution is obtained from above the position of sap flow measuring devices, it might be missed. That is why instantaneous measurements of transpiration and sap flow sometimes fail to agree (Grime *et al.*, 1995a). Nevertheless, all thermal methods mentioned above, if carefully set up, are capable of generating good agreement between daily sap flow and transpiration measured as weight loss from covered potted tree or cut stem (Smith and Allen, 1996).

Conducting wood vessels

The distribution of conducting vessels in wood determines where sap flow occurs. In ring porous wood, sap moves primarily through vessels in the most current annual growth ring (Granier *et al.*, 1994). In diffuse porous wood, vessels are scattered within the functional sapwood, but most sap flow occurs in the larger, new ones for each annual ring (Kozlowski and Winget, 1963).

Sap flow does not occur in heart wood (Whitehead and Jarvis, 1981), or in the immature newly differentiating tissue just inside the cambium, or in late wood (Booker and Swanson, 1979) of coniferous trees. Movement of the heat pulse through the heartwood is due to heat transfer by moving sap in the adjacent vessels (Swanson, 1981).

Vessel (tracheid) layout in the stem is such that efficiency and safety are maintained. Efficiency of transport is mainly through large diameter vessels, but these have to be small enough to maintain mechanical strength. Vessel length also reduces resistance to sap flow through avoidance of traversing of pits, but then again there is less risk of breakage of the water column in shorter vessels. Another protective measure to maintain transpiration is the fanned out arrangement of vessels such that damage of a trunk at any point does not result in damage of the whole length of the conductivity pathway.

Vessel number is another way of increasing conducting efficiency. At branch and petiole junctions, hydraulic resistance is high, preventing rapid loss of water especially in drought conditions (Zimmermann, 1983).

Conservative water users are better adapted to conditions when water is available for an extended period. Where water is available only for a short while, opportunistic water users are more likely to benefit from it before it is lost in form of surface evaporation, deep percolation or uptake by competitors (Zimmermann, 1983). It does not follow though, that opportunistic water users may assimilate more dry matter than conservative ones in case of short-term water availability. All it shows is that opportunists transpire more. This lead into the matter of water use efficiency.

Water use efficiency of plants changes when they are water stressed (Ong *et al.*, 1996) and the most sensitive stages occur at seedling establishment and crop anthesis (Howard *et al.*, 1997; Mooney, 1980). Interestingly, some dryland species shed their leaves to conserve water immediately drought sets in but flush new leaves before the rains start. Then, available soil moisture, which is stored in soil profile, is used by species that maintain greater leaf area during drought when other species shed theirs.

However, the presence of many leaves does not automatically imply increased photosynthesis as some leaves may have reduced transpiration, but efficiency of water use and stomatal activity determine photosynthetic processes (Fischer, 1980). Water use efficiency was not part of this study and therefore will not be discussed in detail.

2.5 Light capture and utilization in AF systems

2.5.1 Theory

Solar energy is the source of energy for the physiological process of plants. Radiant energy is converted into chemical energy by leaves and stored by the plants for further use. The interception and utilization of light, therefore, limits dry matter production of actively growing plants.

Light regimes in plant canopies are influenced by several physical and biological factors such as solar position, plant structure, leaf geometry, size, anatomy, age, height and arrangement of the plants in the field. Moreover, the success and survival of individual plants in mixed AF systems depends upon how they intercept, compete for and respond to light (Ludlow, 1978).

Competition for light has been observed to cause reduction in arable crop yields in various AF systems (e.g., *Leuceana leucocephala* with maize, Kang *et al.*, 1981; Srinivasan *et al.*, 1990). Shading by *Leuceana leucocephala* caused reduced yield of *Zea mays* and *Vigna sinensis* growing adjacent to it (Karim *et al.*, 1991).

Light transmission through upper story canopies depends on their leaf area and light extinction coefficients (Jackson and Palmer, 1989).

The effects of shading on the under story, on the other hand, depends on its light requirements. Light (PAR) saturation in potato (*Solanum tuberosum*) occurs at 450 W/m², in bean (*Phaseolus vulgaris*) at 600-650 W/m² (Salc, 1975) and in cabbage (*Brassica oleracea*) at about 800 W/m² (Jackson, 1983). Light interception by maize decreases more gradually than water uptake after the plant matures (Howard *et al.*, 1997). Light use efficiency of maize is conservative at about 1.3 to 1.4 g/MJ (Squire, 1990; Howard *et al.*, 1997).

Shading during the reproductive stage resulted in less pod production and increased leaf area and internode length of groundnuts, but shading during the pod-filling stage had no effect on development (Stirling *et al.*, 1990). Shaded leaves tend to operate at a greater light use efficiency, but they suffer from premature senescence (Stirling, 1990; King, 1994). Shading can result in increased leaf biomass to fine root biomass ratio (Messier, 1992). Biomass partitioning between the root and shoot is driven more by light intensity rather than light quality (Messier, 1992).

Competition for light occurs when the presence of one plant reduces the net photosynthesis of another by reducing the amount of radiant energy it receives. In the context of photosynthesis, the solar spectrum can be divided into two fractions. The waveband between 400 and 700 nm, which most plants use for photosynthesis, is referred to as photosynthetically active radiation (PAR). In the tropics, the ratio of PAR to total solar radiation has been found to be 0.51 for clear sky conditions and 0.63 for cloudy conditions (Stigter and Musabilha, 1982).

The fraction of PAR in the coming solar radiation at the top of a crop canopy can be separated into that reflected by the canopy and that which is effectively available to plants (Net), that is:

$$\text{Net PAR} = \text{incoming PAR} - \text{Reflected PAR} \dots\dots\dots \text{(Equation 2.10)}$$

Part of Net PAR is absorbed by the plants, while the other is transmitted to the ground that is:

$$\text{Net PAR} = \text{Transmitted PAR} + \text{Absorbed PAR} \dots\dots\dots \text{(Equation 2.11)}$$

Experimentally, the absorbed PAR is estimated by the difference between the net and transmitted PAR, though more commonly the interception of PAR by canopies is assessed from the difference between incoming PAR and transmitted PAR.

Solar radiation received directly from the sun is called direct or beam radiation. Its irradiance on a horizontal surface is proportional to the sine of the solar angle, which varies during the day and with latitude and season. Some of the solar radiation is, however, scattered by gas molecules of the atmosphere (e.g. dust, gas, clouds) and is received as diffuse radiation. Diffuse radiation is richer in PAR than direct radiation as it emanates from the whole sky hemisphere and its proportion of total radiation increases with cloudiness (Szczic, 1974a). Because of the greater penetration of diffuse light and the progressive absorption of direct light, the proportion of diffuse to direct increases with depth in the canopy.

2.5.2 Light interception in boundary tree planting AF

Vertical gradients in light interception are important depending on the relative heights of the tree and crop components. In this AF system, the crop is shorter and has a much smaller leaf area than the tree component.

It is, therefore, at a competitive disadvantage relative to the trees with large canopies. Because the canopies are separated vertically, the relationship between the two species can be analyzed as a permanent shading of the crops by the trees. In this case, it is possible to treat the tree and crop canopies as vertically discrete strata intercepting light (Ong *et al.*, 1996), therefore, the quantification of light interception and conversion by each component is done by using sensors located above and below the tree and crop canopies.

Line planting of a 7-year old *Paulownia* trees had light transmissivities that ranged from 50, 55 and 35%, for 3, 7.5 and 12 m respectively from the lines of trees (Newman *et al.*, 1998). Maize yields were 63% of the sole crops and light was found to be the limiting factor in the system. Zhang (1996) working in a temperate climate in UK found that a line of Poplar trees shaded under-story grass to a distance of 2 m from the tree line. The amount of the incident radiation reaching the grass beneath the trees was 49% compared to that in the open.

Several studies in the literature also show that unpruned hedgerows behave like upper-story trees in terms of light competition with crops. Daniel *et al.* (1991), using lines unpruned pigeon pea interplanted with various crops, found that shading by the pigeon pea extended up-to 1 m and PAR reaching the under-story crop ranged from 46 to 57%. Unpruned 2-year-old black locust tree (*Robinia pseudoacacia*) imposed serious competition for light on the interplanted maize crop (Ssekabembe *et al.*, 1997).

The amount of PAR reaching under-story maize crop in the unpruned hedges ranged from 22 to 25% compared to that in the open. Miah *et al.* (1995) found that the unpruned hedgerows of *Gliricidia sepium*, *Acacia auriculiformis* and *Acacia mangium* reduced light incidence on the under-story rice and mungbean crops by 53 to 59%, thereby causing reduction in crop yields.

Similarly, Corlett *et al.* (1992b) found that reductions in millet yield of 69 to 77% relative to sole millet was attributed to reductions in mean daily solar radiation and mean seasonal fractional light interception by *Leuceana leucocephala*, due to its greater canopy development increased shading (Howard *et al.*, 1995).

2.5.3 Methods of measuring light interception in AF systems

Light interception by plants can be measured directly or indirectly. Sheehy (1985), Pearcy (1989) and Sinoquet and Caldwell (1995) have reviewed the main methods for measuring intercepted radiation by crops. Indirect estimation of the light interception consists of measuring variables that are strongly dependent on light capture. Such methods include single leaf photosynthesis (Beyschlag *et al.*, 1990), plant CO₂ assimilation or transpiration and dry matter production (Rimington, 1985; Sinoquet *et al.*, 1990).

However, indirect estimation methods always involve additional mechanisms that may themselves fluctuate as the result of resource availability. Consequently, the general reliability of such approaches is questionable, but they may be “useful” in providing estimates, especially in case of mixed foliage (Sinoquet & Caldwell, 1995).

In direct measurements, radiation sensors measure downward and upward radiation fluxes within the canopy (Sinoquet & Caldwell, 1995). In particular, sensors located at the upper and lower bounds of the canopy allow one to obtain a radiative balance of the whole canopy (Varlet-Grancheer and Bonhomme, 1974). Plant scientists have used two types of sensors, the energy (PAR) sensor and the photon (quantum) sensor (Newman, 1989), to measure light interception by plants.

The quantum sensor is often preferred for measurement of photosynthetic efficiency in relation to absorbed PAR, whilst the energy sensor is preferred for the measurement of PAR in relation to canopy transmissivities (Blackburn & Proctor, 1983; Corlett *et al.*, 1992a; 1992b). Tube solarimeters sensitive to radiant energy over the whole spectrum and the quantum sensors, which respond to the wavelength band from 400 to 700 NM, are the most commonly used sensors for measuring light interception by plant canopies.

Contrary to homogeneous monocultures, measuring light capture in intercrops requires a great number of sensors in order to integrate variation due to the canopy structure and distinguish light interception between species. Low-cost sensors are useful in avoiding experimental limitations in other types of radiation field measurements. New sensors such as Amorphous Silicium Cells (ASC) correctly measure quanta fluxes in PAR waveband (Chartier *et al.*, 1989). Newman (1985, 1998) used low-cost E cell coulometers for longtime integration. Tracking systems that move sensors along a transect provide an alternative way to integrate spatial variation (Perch, 1986; Matthews *et al.*, 1987).

2.6 Description of study tree species

In Siaya, farmers were reported to prefer *Markhamia lutea*, *Eucalyptus* species, *Grevillea robusta*, *Casuarina equisetifolia*, *Senna siamea* and *Acacia mearnsii* for boundary planting (AFRENA, 1997). For the purpose of this study, the top 4 most preferred species for household needs by farmers were selected.

The four tree species which were selected for this study at Siaya are reviewed as follows and references for species description is mainly taken from Doran and Turnbull (1997), ICRAF (1998), MacDicken (1994), National Academy of Sciences (1994) and Useful trees and Shrubs for Tanzania (1994).

2.6.1 *Casuarina equisetifolia* L.

2.6.1.1 Botanic description

An evergreen, dioecious or monoecious tree 6-35 (60) m tall, with a finely branched crown. Crown shape initially conical but tends to flatten with age. Trunk straight, cylindrical, usually branchless for up to 10 m, up to 100 (max. 150) cm in diameter, occasionally with buttresses. Bark light greyish-brown, smooth on young trunks, rough, thick, furrowed and flaking into oblong pieces on older trees; inner bark reddish or deep dirty brown, astringent.

The branchlets are deciduous, drooping, needlelike, terete but with prominent angular ribs, 23-38 cm x 0.5-1 mm, greyish-green, articles 5-8 mm long, glabrous to densely pubescent, dimorphic, either deciduous or persistent. Twigs deciduous, entirely green or green only at their tips. The minute, reduced, tooth like leaves are in whorls of 7-8 per node.

Flowers unisexual; perianth absent, replaced by 2 bracteoles. Male flowers in a terminal, simple, elongated spike, 7-40 mm long, borne in whorls with 7-11.5 whorls/cm of spike, with a single stamen. Female inflorescence on a short lateral

branchlet, cylindrical, cone-shaped or globose, 10-24 x 9-13 mm; bracteoles more acute, more or less protruding from the surface of the cone. Inflorescence a woody, conelike structure. Fruit a grey or yellow-brown winged nut (samara).

2.6.1.2 Ecology and distribution

Casuarina equisetifolia has the widest distribution of all *Casuarina* species and occurs naturally on subtropical and tropical coastlines from northern Australia throughout Malaysia, southern Myanmar and the Kra Isthmus of Thailand, Melanesia and Polynesia. It is doubtfully indigenous to the Mekong Delta in Vietnam and to Myanmar and possibly also to Madagascar. It has also been introduced to a number of countries, where it is often naturalized. By 1954 South China had established an estimated one million hectares.

The climate in its natural range is semi-arid to sub-humid. In most regions there is a distinct dry period of 4-6 months, although this seasonality decreases towards the equator in Southeast Asia and in the southern parts of its range in Australia.

Casuarina equisetifolia is commonly confined to a narrow strip adjacent to sandy coasts, rarely extending inland to lower hills, as in Fiji. Found on sand dunes, in sands alongside estuaries and behind fore-dunes and gentle slopes near the sea. It may be at the leading edge of dune vegetation, subject to salt spray and inundation with seawater at extremely high tides. *Casuarina equisetifolia* may be the only woody species growing over a ground cover of dune grasses and salt-tolerant

broadleaved herbs; it can also be part of a richer association of trees and shrubs collectively termed the Indo-Pacific strand Florida, USA. It seeds freely throughout the area and has spread rapidly like a weed (National Academy of Sciences, 1994).

Altitude ranges from 0 to 1400 m, Mean annual temperature ranges from 10 to 35 °C. Mean annual rainfall is between 200-3 500 mm. Soils are invariably well-drained and rather coarse textured, principally sands and sand loams. The species tolerates both calcareous and slightly alkaline soils but is intolerant of prolonged water logging and may fail on poor sands where the subsoil moisture conditions are unsatisfactory.

2.6.1.3 Propagation and management

Casuarina equisetifolia is wind pollinated. Trees are mostly monoecious. Female cones mature about 18-20 weeks after anthesis and open shortly after this, releasing small samara. Fruit on a tree does not all mature at the same time, often presenting a problem for seed collection. In cultivation, *C. equisetifolia* hybridizes with *Casuarina glauca* and *Casuarina junghuhniana*.

Propagation is mainly by seed; however, there is an increasing use of cuttings. Seeds can be sown without pre-treatment but should be protected from ants. Germination takes up to 2 weeks and is epigeal. Plantations can be established using containerized seedlings, bare root seedlings or rooted cuttings. Seedlings should be planted in well-drained light soils, not clay soils, to decrease the incidence of diseases and pests. Appropriate watering, correct spacing of plants and adequate light should check

damping-off in the nursery. Seedlings can be pricked out when 3-10 cm tall and transferred to beds or containers. Plants are typically suitable for out-planting when 25-30 cm tall.

A planting density of 2 500 stems/ha is commonly used but some farmers plant up to 8 000-10 000 stems/ha when fuelwood and small poles are the required product. *Casuarina equisetifolia* is a poor self-pruner. Side pruning is necessary up to 2 m to make plantations accessible for maintenance. *Casuarina equisetifolia* is not fire resistant and protection is necessary. It coppices only to a limited extent and best results are obtained when cut young.

Timely thinning is essential as the species demand light. For timber production, an intermediate thinning will be required for stems to develop. Young trees are susceptible to competition from weeds, especially grasses. They are susceptible to drought until their roots reach the groundwater table, which may take up to 2-3 years after planting. The species is also susceptible to termites.

Casuarina equisetifolia has a life span of 40-50 years and displays fast early growth. Under favourable conditions, early growth rates are about 2 m/year in height and the trees have good form in cultivation. On favourable sites, it can yield an annual increment of 15 cubic m/ha of wood in 10 years. In India, plantations using 1 x 1 m or 2 x 2 m spacing on 6-15 year rotations yield 50-200 t/ha. Dry weight per tree ranges from 15 to 25 kg at 3 years of age, depending on site quality.

In South China, where an estimated one million hectares in shelterbelts along the coastal dunes have been established since 1954, heights of 7-8 m and diameters of 5-7 cm are achieved in about 4 years. The rotation period ranges from 4-5 years for fuelwood and 10-15 years for poles. Mean annual increments usually fall in the range of 4-5 cubic m/ha per year.

2.6.1.4 Functional uses

The highly regarded wood ignites readily even when green, and ashes retain heat for long periods. It has been called 'the best firewood in the world' and also produces high-quality charcoal. Calorific value of the wood is 5000 kcal/kg and that of the charcoal exceeds 7 000 kcal/kg. It has been used for both domestic and industrial fuel such as for railroad locomotives. In Asia, leaf litter from plantations is often removed to be used as fuel. The wood is used to produce paper pulp using neutral sulphate and semi-chemical processes, and as a raw material for rayon fibres.

Casuarina equisetifolia yields a heavy hardwood with an air-density of 900-1000 kg/m³. Heartwood is pale red, pale brown to dark red-brown, moderately to sharply differentiated from the sapwood, which is yellowish or pale yellow-brown with a pink tinge. Grain is straight, slightly interlocked or wavy; texture fine to moderately fine and even. Shrinkage is moderate to very high, and in the latter case the wood is difficult to season due to severe warping and checking. Wood is hard to very hard and strong.

The heartwood is highly resistant to pressure treatment, but sapwood is amenable to such treatment. On sawn timber, the rays are prominent on radial faces. Uses include house posts, rafters, electric poles, tool handles, oars, wagon wheels and mine props. The bark contains 6-18% tannin and has been used extensively in Madagascar for tanning purposes. It penetrates the hide quickly and furnishes swollen, pliant, soft leather of pale reddish-brown colour. Root extracts are used for medical treatment of dysentery, diarrhoea and stomach-ache. In West Malaysia, a decoction of the twigs is used for treating swelling and the powdered bark is used for treating pimples on the face.

Since it is salt tolerant and grows in sand, *C. equisetifolia* is used to control erosion along coastlines, estuaries, riverbanks and waterways. In Sarawak, Indonesia the species is protected because of its importance in controlling coastal erosion. The abundance of highly branched twigs absorbs wind energy amazingly well. In areas with hot, dry winds the tree protects crops and animals herds. In South China, an estimated one million hectares has been established in shelterbelts along the coastal dunes.

Root nodules containing the actinorhizal symbiont *Frankia* enable *C. equisetifolia* to fix atmospheric nitrogen. These root nodules can be prolific. *Casuarina equisetifolia* possesses proteoid roots and forms associations with vesicular arbuscular mycorrhizae.

It is grown as ornamental along streets and seashores. It can be pruned into hedges and used as a fence around food crops. With high productivity and properties that enhance soil fertility, *C. equisetifolia* shows promise as an AF species for arid and semi-arid areas. Experiments at Prabhunagar, India, showed citrus trees grew larger under *C. equisetifolia* than in pure stands.

2.6.2 *Eucalyptus grandis* Hill ex Maid.

2.6.2.1 Botanic description

Eucalyptus grandis attains a height of 45-55 m, usually with an excellent trunk and a wide-spreading, rather thin crown; most of the bark and branches are smooth, white or silvery, sometimes greenish, rough on lower stem, smooth above, debark easily. Juvenile leaves are petiolate, opposite for several pairs then alternate, ovate up to 16 x 8.5 cm, green to dark green and slightly wavy; adult leaves are petiolate, alternate, stalked, lanceolate to broad lanceolate, up to 15 x 3 cm, green on topside and pale green on underside, slightly wavy, with a long point.

Fruit or seed capsules several, short stalked, pear shaped or conical, slightly narrowed at the rim, thin, 8 x 6 mm, with whitish waxy coating, narrow sunken disc, and 4-6 (commonly 5) pointed, thin teeth, slightly projecting and curved inward, persisting on twigs.

The genus *E. grandis* was described and named in 1788 by the French botanist l'Héritier. The flowers of various *Eucalyptus* species are protected by an operculum, hence the generic name, which comes from the Greek words 'eu' (well) and 'calyptos' (covered). The specific epithet, 'grandis', is Latin word for 'large' or 'great'.

2.6.2.2 Ecology and distribution

Eucalyptus grandis is native to Australia and was introduced in South Africa before 1885, and by 1973 there were 275 000 ha planted, 75% of all *Eucalyptus* species in the country. The species was introduced to a number of other countries during 1890-1920, including Angola, Zimbabwe, India, Brazil, Argentina, Uruguay and the East African region.

In its natural range, *E. grandis* grows in tall, open forest in sheltered valleys and on hill slopes, often in pure or almost pure stands, sometimes in mixed forests. In the southern part of its natural range, it is found on flats and lower slopes of deep, fertile valleys and at the edge of rainforests.

Altitude ranges from 0 to 2700 m while mean annual temperature ranges from -1 to 40 °C. Mean annual rainfall ranges from 100 to 1800 mm. *Eucalyptus grandis* needs a deep, free-draining soil, and does best on fertile loam or clay-loam soils, but it will also perform well on lighter sandy soils, provided these are deep enough.

2.6.2.3 Propagation and management

The flowers are bisexual, with fertile male and female organs on the same flower. Pollination is dependent on insects or animal vectors. Like many *Eucalyptus* species, it has a tendency to out-breed.

Cuttings are more popular than grafting because of graft incompatibility. Selection can be made from trees already of substantial stature at 4 or 5 years of age, by felling outer lines in plantations and selecting the best trees in these lines. Coppice shoots from stumps have also been used for propagation.

For pulpwood, fuelwood and timber for mining, a 6- to 10-year rotation is common. In most countries, no thinning is done on these short rotations. In Zambia, for industrial plantations, an 8-year rotation is used with thinning at the ages of 2 and 5 years. In the same country, a 4-year rotation without thinning is used for production of small wood for domestic purposes.

Thinning should be done to 3 stems per stump. In Uganda, with initial spacing of 2.4 x 2.4 m to 3 x 3 m, a 7- to 8-year rotation is sufficient to produce trees of 15-20 cm diameter at breast height, the preferred size for tobacco curing. In India, a 9-year rotation is used with initial spacing of 3 x 3 m. For saw logs, a rotation of 30 years is recommended with thinning at ages 7, 11 and 15 years, leaving a final stocking of 250 stems/ha.

The use of boron to reduce die-back and improve the growth rate is essential. For most types of products, 1 seedling rotation, followed by at least 2 coppice rotations, is common practice. Under natural conditions, *E. grandis* bears heavy seed crops every 2-3 years. A fully mature tree can produce 2 kg of seed annually. Young trees of *E. grandis* in the 1st year or 2 after planting are extremely susceptible to termite attack.

2.6.2.4 Functional uses

Eucalyptus grandis blossoms regularly and sometimes heavily but usually provides only small honey surpluses. The tree's main nectar value is as a supporting species. The honey is amber and strongly flavoured but rather thin. Large quantities of the wood are used for charcoal for iron smelting, for example in Brazil. The firewood is used for domestic purposes and for curing tobacco, especially in Uganda.

Eucalyptus grandis has been used for manufacturing sulphate pulp, for example in Brazil, Uruguay, South Africa and Angola. The wood has been used for fence posts, building, transmission, telephone poles, Timber, boxes and hooks. It is especially used for boat building, flooring, plywood, panelling and general construction. It can also be used for sawn timber but has tendency to split.

Soya bean (*Glycine max*) interplanted with *E. grandis* as part of an AF research project in south-eastern Brazil suppressed weeds without adversely affecting *E. grandis* survival and growth. Maize and sorghum have also been found compatible

with *E. grandis*. In South Africa. *Eucalyptus grandis* planted adjacent to avocado orchards reduces the yields by shading and competing unfavourably with the avocados for light, nutrients and water.

2.6.3 *Grevillea robusta* A. Cunn. Ex R.Br.

2.6.3.1 Botanic description

The name commemorates Charles F. Greville (1749-1809), one of the founders of the Royal Horticultural Society of London. *G. robusta* is a deciduous medium-sized to large tree 12-25 (max. 40) m tall; crown conical, dense, with branches projecting upwards. Bole straight, branchless for up to 15 m, up to 80 (max. 120) cm in diameter, usually without buttresses; bark fissured, sometimes pustulate, dark grey to dark brown, inner bark reddish-brown. Leaves alternate, fernlike, pinnately (almost bipinnately) compound, 15-30 cm long, exstipulate; 11-21 pairs side axes (pinnae), 4-9 cm long, deeply divided into narrow, long, pointed lobes 6-12 mm wide, upper surfaces shiny dark green and hairless, underneath silky with whitish or ash-coloured hairs.

Flowers showy, yellowish, numerous, paired, on long slender stalks 1-2 cm, composed of 4 narrow yellow or orange sepals 12 mm long. Flower clusters 7.5-15 cm long, unbranched, arising mostly from the trunk, in a terminal or axillary simple or branched raceme, protandrous, petals 4, united into a tube that is mostly recurved under the broadened apex (limb); stamens 4, sessile in the concave limb; disk annular or semi-annular, sometimes bilobed; ovary superior, 1-locular with 2 ovules, style

curved and protruding from a slit in the perianth tube, the apex free from the limb, eventually straight, persistent.

Fruits podlike, broad, slightly flattened (boat shaped), 2 cm long, black with long slender stalk and long, threadlike, curved style; 1 or 2 seeds, 10-13 mm long, elliptical, brown, flattened with wing all around a coriaceous to woody follicle, usually oblique and opening along the ventral margin.

2.6.3.2 Ecology and distribution

Grevillea robusta occurs naturally in Australia. It has been introduced into warm, temperate, subtropical highland regions around the world and is widely planted in India, Sri Lanka and many countries in Africa.

Grevillea robusta occurs naturally in 2 distinct habitats: riverine rainforest in association with either *Castanospermum australe* or *Casuarina cunninghamiana*; or in vine forest dominated by *Araucaria cunninghamii*. Rainfall distribution has a summer maximum in the natural range, but *G. robusta* also grows well in climates with a winter maximum or a bimodal rainfall regime. In temperate areas, it can survive moderate winter frosts. It is not resistant to persistent strong winds. In its natural range, the species is semi-deciduous, shedding most of its leaves in the dry season, and can stand up to 6 months of drought.

Altitude ranges from 0 to 2300 m while annual temperature ranges from 14 to 23 to 25 to 31 °C. Mean annual rainfall ranges from 600 to 1700 mm. Establishes well in riverine habitats, on alluvial soils that are free of waterlogging and mildly acid to neutral. Loam soil is preferred. It also occurs on clay loam and sand

The tree first flowers when about 6 years old. In its natural range, flowering occurs over a few weeks in October-November, but when planted in equatorial latitudes, flowering is sporadic throughout the year or absent, as in Jakarta. The flowers are bisexual, and pollen is shed before the stigma becomes receptive. Pollinating agents include honeybees, birds and arboreal marsupials (Phalangeridae), which collect nectar and pollen from flowers.

The period from fertilization to fruit maturity is about 2 months. Fruit opens during hot, dry weather, releasing the seeds, which can be carried considerable distances by wind. In Java, *G. robusta* has mature fruit from September to January. Seed dispersal is by wind.

2.6.3.3 Propagation and management

Grevillea robusta can be propagated through seed and cuttings, although seed is difficult to collect because of the great size of the tree. No pretreatment of seed is required, and it germinates readily in a moist environment. The optimum temperature for germination is about 25 °C at a rate of 60-80% in 20-28 days. Cuttings can be

casily established using shoots from seedlings or saplings, which can also be air-layered.

Grevillea robusta is moderate to fast growing. When climate and soil are suitable and weed competition is not severe, annual height and diameter increments of at least 2 m and 2 cm, respectively, are usually achieved for the 1st few years in row planting on farms. Annual height increments of 3 m have been observed at the most favourable sites. *Grevillea robusta* regrows well after complete defoliation following pruning and pollarding, which can be carried out repeatedly to yield wood and to regulate shading and competition with adjacent crops. It is characterized by root suckering, hence it is a good candidate for management under coppice rotation; it responds well to pollarding, lopping and pruning.

A plant density of 800-1200 trees/ha is recommended for plantations. Some control of competing vegetation is required for the 1st 1-2 years after planting. Seedlings are normally planted at a spacing of 2.5-3 x 3-4 m. The relatively open canopy of *G. robusta* makes it less suitable for areas with erosional hazard. It also easily regenerates naturally, especially in agricultural fields. For firewood production, rotations of 10-20 years are applied and annual volume increments of 5-15 cubic m/ha may be expected. A growth reduction after 20 years is reported. The species is known to produce substances toxic to its own seedlings.

2.6.3.4 Functional uses

The golden flowers are attractive to bees, making it an important honey plant. *G. robusta* is popular for firewood and charcoal. It is also used to fuel locomotives and river steamers, power boilers and small industries. The calorific value of sapwood is about 4800 kcal/kg, while that of heartwood is 4950 kcal/kg. Mean fiber length is about 1.5 mm and width about 26 μ m; the wood is suitable for pulping.

Grevillea robusta yields a medium-weight hardwood with a density of 540-720 kg/cubic m at 15% moisture content. The timber has economic potential. Heartwood is pale pink-brown, turning to yellow-brown or red-brown on exposure; moderately clearly differentiated from the cream-coloured to pale pink sapwood; grain straight to wavy; texture medium to coarse and uneven; wood lustrous; prominent silver grain on radial surface.

Shrinkage upon seasoning is low to moderate; seasoning properties are rated from good to poor; wood air-dries slowly. It has a tendency to warp and check; therefore, thick material should be air-dried slowly followed by a mild kiln schedule to avoid honeycombing. The wood is hard, of low strength, but elastic, can be peeled and sliced satisfactorily, is moderately durable to non-durable and shows an absorption of creosote of 128 kg/cubic m when treated by open-tank method and 321 kg/cubic m with pressure treatment. The wood is susceptible to marine borer, pinhole borer and termite attack.

It is easy to work with hand and machine tools, but cutting at an angle of 10 degrees is required to obtain a good finish on quarter-sawn faces. The wood is used in making railroad ties, plywood, panelling, air-freight cases and furniture, parquetry, turnery, boat building, interior trim, cabinet work, parquet flooring, boxes, toys and novelties. Gum or resin: by virtue of their solubility, viscosity and relatively high resistance to hydrolysis, *G. robusta* gums may have some industrial applications.

The flower buds, fruit and seeds are cyanogenic. Through contact with the leaves, sensitive persons may develop contact dermatitis due to tridecylresorcinol, a chemical compound related to the allergen toxicodendron.

Grevillea robusta is grown as a shade tree in coffee and tea plantations. Its spreading branching system makes it ideal for windbreaks or shelterbelts against wind-induced mechanical damage, high rates of transpiration and surface evaporation. *Grevillea robusta* is a pioneering colonizer of disturbed sites. *Grevillea robusta* provides abundant quantities of leaf mulch, which may accumulate to a depth of 30-40 cm. This thick layer protects the soil and maintains soil temperature. The leaves and twigs are apparently rich in aluminium.

Its majestic height, attractive shape and beautiful foliage make *G. robusta* an ideal tree for landscaping of private and public gardens. The cut leaves are used in flower arrangements, and young plants are grown as indoor pot plants in Europe.

A deep rooting system causes little interference with shallow-rooted crops, and it can be successfully intercropped with banana, tomato and other agricultural crops. The species is prone to termite attack in the tropics.

2.6.4 *Markhamia lutea* Benth.

2.6.4.1 Botanic description

Markhamia lutea is an upright evergreen tree 10-15 m high, with a narrow, irregular crown and long taproot. The bark is light brown with fine vertical fissures. Leaves are compound, often in bunches, thin and wavy, each leaflet is up to 10 cm, wider at the tip, often with round outgrowths at the base.

Flower buds are yellow-green and furry, splitting down 1 side as flower emerges. Flowers are bright yellow, in showy terminal clusters, each trumpet shaped, to 6 cm long, with 5 frilly lobes, the throat striped with orange-red.

The fruit is very long, thin, brown capsules, to 75 cm in length, hanging in clusters and tending to spiral, splitting on the tree to release abundant seed with transparent wings, 2.5 cm long and yellow-whitish when mature. The genus was named after Sir Clement Markham, who introduced the famous quinine-yielding cinchona into India. The specific epithet, 'lutea', is Latin for golden-yellow.

2.6.4.2 Ecology and distribution

Markhamia lutea is common in the lake basins and highland areas of eastern Africa. The tree is drought resistant but cannot withstand water logging. The species is native to Ethiopia, Kenya, Tanzania and Uganda.

Altitude ranges from 900 to 2000 m. Mean annual temperature ranges from 12 to 27 °C while mean annual rainfall ranges between 800 to 2000 mm. Trees prefer red loam soil but can tolerate well-drained, heavy, acidic clay soils.

Markhamia lutea trees flower for much of the year. In western Kenya, flowering occurs from August to September, followed by seeding in February to March. Fruits develop within 6 months of insect pollination.

2.6.4.3 Propagation and management

Natural regeneration is mainly by seed. Pretreatment is not necessary, and under ideal conditions, seeds germinate within 20-30 days, with an expected rate of 30-60%. Trees may also be propagated by seedling or wildings.

Markhamia lutea grows fast in good forest soil, and plants can attain growth rates of more than 2 m/year. Trees can be pruned and pollarded to reduce shading and are coppiced when they are about 1.7 m in height. Pods should be collected from the

trees after they turn grey. Young trees are often attacked by shoot borers, resulting in crooked stems.

2.6.4.4 Functional uses

Markhamia lutea provides good bee forage. Trees are a source of firewood and produce good charcoal. Fuelwood is used to cure tobacco in western Kenya. The wood, which is fairly resistant to termites, is used for furniture, poles, posts, tool handles and boat building. Leaves are known to have medicinal value.

Markhamia lutea is recommended for use in soil-conservation. The species provides useful shade and acts as a windbreak. It provides mulch, which enhances soil-moisture retention and increases organic matter. *Markhamia lutea* poles can be used as props to support banana trees and along field boundaries.

Although *M. lutea*, *C. equisetifolia*, *E. grandis* and *G. robusta* are a very promising AF trees in western Kenya, there is not enough information available in-terms of their management, such as crown and root pruning, effects on growth and yield of crops when planted along agricultural fields as boundary plantings.

CHAPTER THREE

3.0 MATERIALS AND METHODS

The study consists of farmers' survey at Siaya and field experiments at Siaya and Nyabeda, western Kenya. The two experimental sites were chosen on the basis of the problems identified during earlier survey (Tefera, 1999). Thus, this chapter describes the materials and methods used in this study. It covers the following: the procedures and methods used in the farmers' survey, description of the sites where the studies were conducted and the tree species and crop that were used in the study. It gives details on experimental designs used and the establishment, management and assessments of farmers, trees, crop yield, soil water, light and tree water uptakes (sap flow). It also describes the types of data analysis used for farmers' survey, tree parameters, maize yields, soil water, sap flow and light interception, by both trees and maize crops.

3.1 Farmers' survey

Prior to initiation of the field trials, a base line survey was conducted in Siaya starting from January 1999 with the specific objective of identifying tree species grown on-farm, gathering farmers knowledge of trees for farmlands, constraints for tree planting and their willingness to plant economically valuable trees on crop land. Farmers' tree pruning practices and their observations of tree-crop interactions were also recorded.

The study was carried out in six randomly selected villages in Siaya (see section 3.2.1.1 for site description). Within each village, about 5-10 farmers were selected systematically for detailed survey (Franzel, 1996) and stratified sampling of farmers (Scott, 1985) was adopted in order to cover a range of farmers (women vs. men, small vs. large holdings, Appendix 1). Sample stratification also included information such as sex, income, education level and age. Sample farmers were chosen to give maximum coverage of the area. Structured questionnaire (Franzel, 1996) was used to find out whether or not farmers intercrop trees with crops, the types of intercrops, the complexity/degree of tree pruning and period(s) of tree pruning (Appendix 1). To avoid interview fatigue the questionnaire was divided into three broad sections:

1. household characterization
2. tree planting, niches or patterns of tree planting on farms etc.
3. farmers' tree pruning (management) practices and their observation of tree-crop interactions.
4. farmers' future plans and their constraints in growing trees with crops on their farms.

3.2 Field experiments

Two field experiments were carried out i.e. one at Siaya and the other at Nyabeda in western Kenya.

3.2.1 Siaya site

3.2.1.1 Site description

The field experiment carried out in Siaya (crop based land use system) District is located in Nyanza province in western Kenya (Figure 3.1). The District has an area of 3,528 square kilometres of which 1,005 square kilometres are under Lakes Sare and Kanyboli, adjoining the Yala swamp, and portion of Lake Victoria. Siaya has an average farm size of 1.4 hectares and a population density of about 400 person/km².

Siaya district is not well endowed in natural vegetation apart from few scattered woodlots of naturally growing trees such as *M. lutea* and few planted exotic species such as *E. grandis* and *G. robusta*. There are no gazetted forest resources. It is therefore one of the districts in the country that is least afforested (Siaya District Development Plan, 1993).

The field experiment with an over all objective of evaluating the effect of crown and root pruning treatments on utilization of soil water, tree and maize growth and yield was carried on an existing four-year-old trial entitled "Effect of phosphorus fertilizer application on the growth rate of six multipurpose tree species for pole production in boundary planting configuration." The experiment was established at the Siaya Institute of Technology farm (0° 04'N, 34° 17'E and at about 1300 masl.) in November 1995. The experimental area slope rises gradually from 0% east to about 3% to the west.

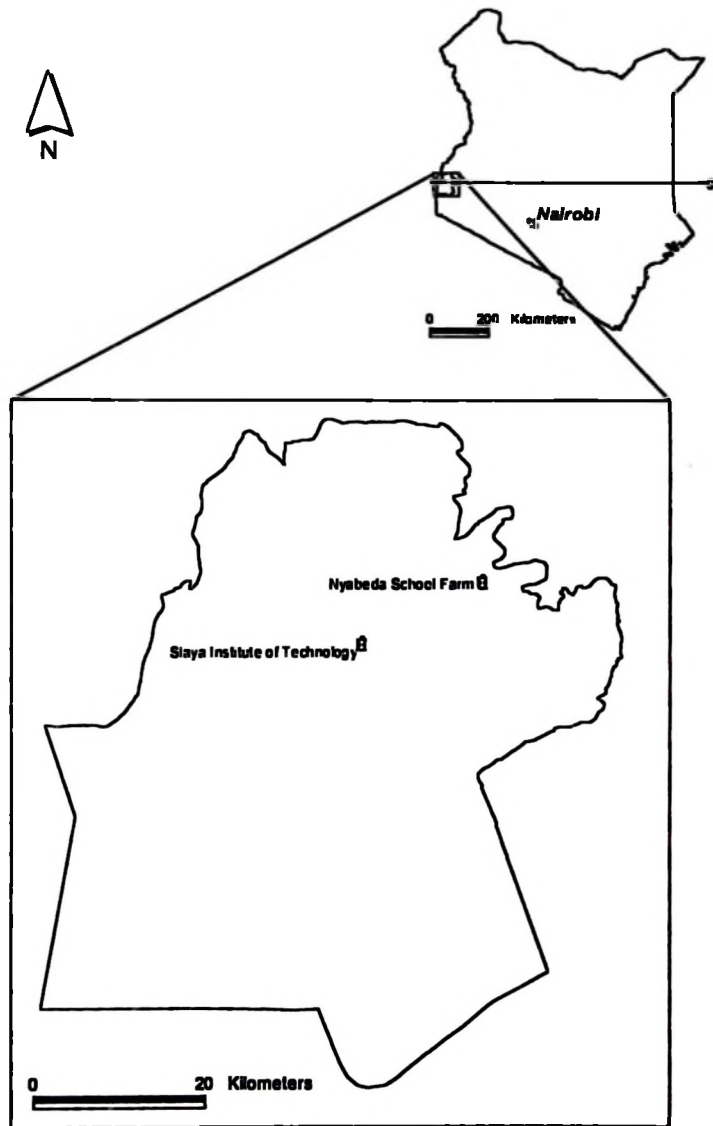

Figure 3.1: Location of Siaya and Nyabeda experimental sites in western Kenya.

The climate conditions are described using the data of Maseno, Usingu Dispensary (EAMD registration no. 90.34021) rainfall station which has a rainfall record of 28 years (Figure 3.2), and is about 30 km south east of the experimental site at an altitude of 1220 masl. Rainfall is bimodally distributed and averages about 1200 mm per year. The rainfall per year is not uniformly distributed. The highest proportion is received in only few days and therefore, drought is frequent. Long rains occur from March to August, peaking in April-May (Figure 3.2). Short rains are from September to January with peak in October-November. The mean annual temperature is estimated to be 22^oC. Potential evapotranspiration as calculated by Penman-Montieth equation is 452 mm in the short rains and 497 mm in the long rains, about 3 mm⁻¹day.

Soils are Eutric Ferralsol (FAO/UNESCO, 1988) and are dominantly developed on andesites. These soils are well-drained, very deep (>3m), reddish-to-reddish brown, friable loamy sand to loam. They are well structured and are of medium acidity (Table 3.1).

3.2.1.2 Experimental design and treatments

Seedlings of six tree species were planted in 1995 (AFRENA, 1997). From the six species, 4 species (*C. equisetifolia*, *E. grandis*, *G. robusta* and *M. lutea*), which were most preferred by farmers, during the farmers and pole/timber sellers evaluation day at Siaya (Tefera, 1999), were selected and used for this study.

The experimental design was a 4 x 4 factorial combination of tree species and pruning treatments laid out as a randomized complete block design (RCBD), with three replications. The field layout is as shown in Figure 3.3. Treatments and their respective levels were as follows:

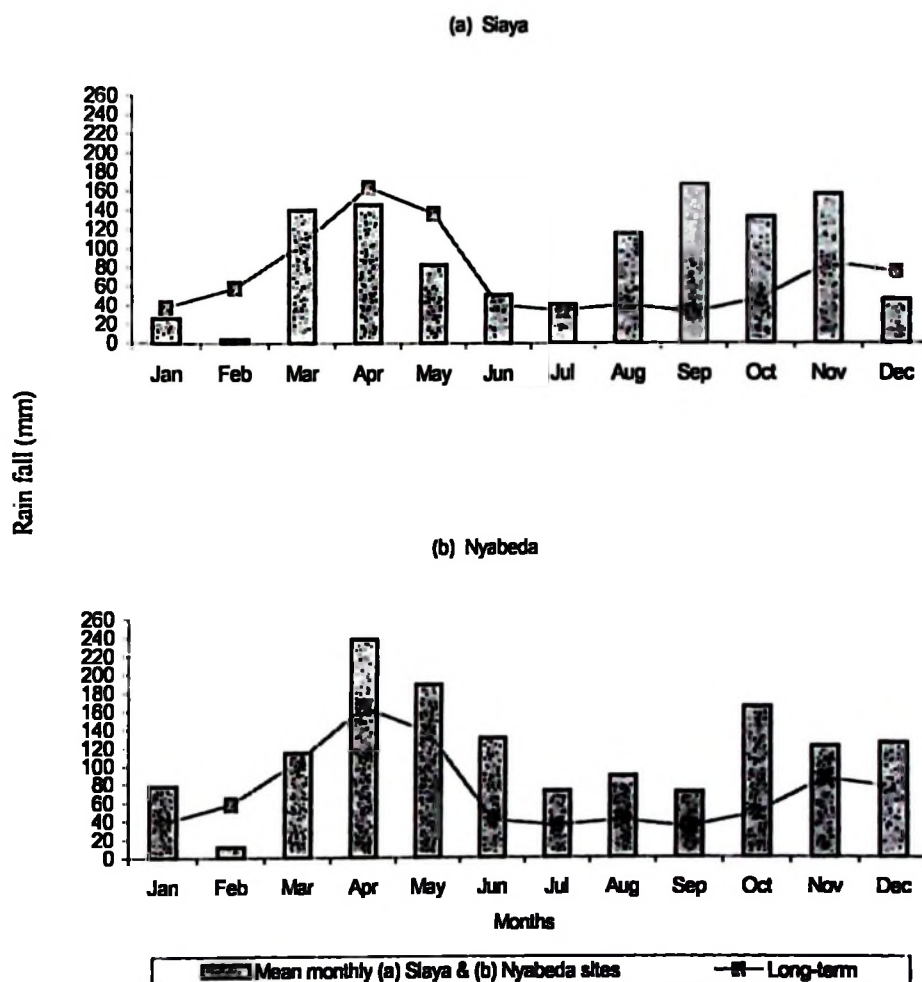

Figure 3.2: Mean monthly rainfall distribution for (a) Siaya (1997-2000) and (b) Nyabeda (1998-2000) in western Kenya.

Table 3.1: Some selected soil properties at Siaya and Nyabeda experimental sites, western Kenya¹.

Siaya

Soil depth (cm)	pH	OC (%)	P (mg kg ⁻¹)	Extractable minerals (cmol _c kg ⁻¹)			Soil textural class (%)		
				Ca	Mg	K	Sand	Silt	Clay
0-15	5.6	1.6	1.2	4.9	2.2	0.2	15.5	26.5	58
15-30	5.6	1.2	0.6	4.7	2.0	0.1	11.5	21.3	67.2
30-50	5.9	0.7	0.3	4.4	1.8	0.1	8.5	15.7	75.8
50-100	5.9	0.6	0.5	4.3	1.5	0.1	7.8	13.2	78
100-150	5.9	0.5	0.6	3.7	1.3	0.0	8.8	11.8	78.3
150-200	5.8	0.3	0.7	3.5	1.3	0.0	9.3	13.7	76
Mean	5.8	0.8	0.6	4.2	1.7	0.1	10.3	17.0	72.2
SED	0.03	0.08	0.06	0.11	0.06	0.01	0.49	0.96	1.31

Nyabeda

0-15	5.5	1.7	1.0	5.9	1.9	0.2	20.3	29.5	50.3
15-30	5.5	1.4	0.8	5.6	1.8	0.1	15.8	22.8	61.5
30-50	5.7	0.9	0.0	4.7	1.6	0.1	11.3	18.3	70.5
50-100	5.8	0.6	0.3	4.2	1.2	0.1	9.0	13.8	76.8
100-150	5.9	0.5	1.0	3.9	1.0	0.1	9.3	13.0	78.0
150-200	5.9	0.4	1.0	3.7	0.9	0.0	10.3	14.5	75.3
Mean	5.7	0.9	0.7	4.7	1.4	0.1	12.7	18.7	68.7
SED	0.03	0.10	0.10	0.18	0.08	0.01	0.90	1.25	2.09

¹CRAF soil laboratory, unpublished data; SED = Standard error of the different means.

Tree species (Provenance)

1. *Casuarina equisetifolia* (ex Kitale)
2. *Eucalyptus grandis* (ex Muguga)
3. *Grevillea robusta* (ex Meru)
4. *Markhamia lutea* (ex Bwazri)

Pruning treatments

- 1. Crown pruning
- 2. Root pruning
- 3. Both crown and root pruning
- 4. Control (no pruning)

Note: Crown pruning is cutting of side branches and pollarding.

R = Replication
 T = Types of treatments
 T1 = Crown pruning
 T2 = Root pruning
 T3 = Crown + root pruning
 T0 = Control (no pruning)
 SM = Sole maize

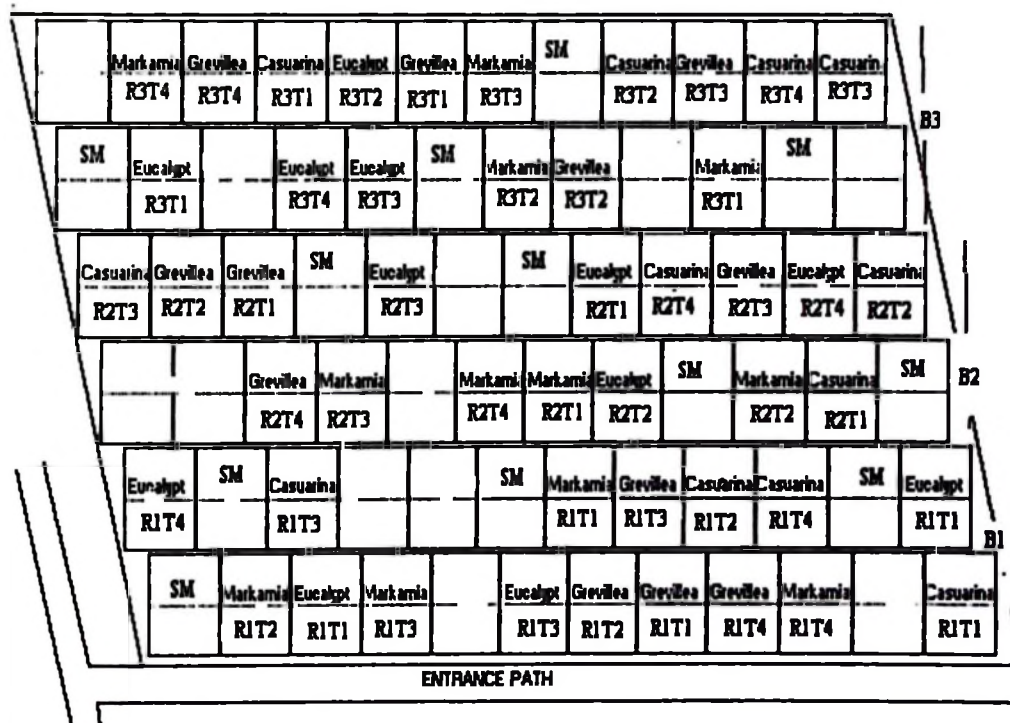

Figure 3.3: Experimental layout of Siaya, western Kenya

3.2.1.3 Experimental establishment

Each block measured 40 m x 100 m while each plot measured 7 m x 8 m. Each plot was made up of a single row of four trees planted at 2 m spacing (Figure 3.4). The following pruning treatments were imposed on all the four trees per plot in March 1999.

1. **Crown pruning:** Crown pruning (pollarding) was carried out at 4 m height. Branch pruning was applied up to 3 meters. Branches between 3–4 m were cut to 30 cm from the tree stem. Machetes (pangas) was used for crown pruning.
2. **Root pruning:** Tree roots were cut at 30 cm length and 30 cm depth from the base of the tree in all directions in circular form. Axe and hoes were used for root pruning.
3. **A combination of crown and root pruning:** Trees were subjected to both crown and root pruning. The procedures and methodologies of the pruning were as described above for crown and root pruning.

4. **Control:** Trees were left un-pruned (without crown or root pruning) for comparison with other treatments.

As noted above, the spacing between trees was 2-m. The spacing used for maize was 0.75-m for inter row and 0.25-m intra row. For the purpose of comparison the rows of maize were numbered from 1, being the nearest to the tree lines, to 4 being the furthest from the tree lines (Figure 3.4).

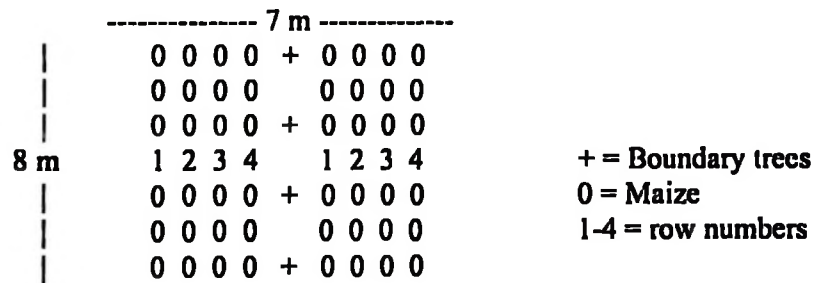

Figure 3.4: A field layout showing the arrangement of trees and maize rows in a plot at Siaya, western Kenya.

3.2.2 Nyabeda site

3.2.2.1 Site description

The Nyabeda tree root pruning experiment was located at the Nyabeda school farm (0° 08'N, 34° 25'E, 1300 masl) in Siaya district, western Kenya (Figure 1).

Climate is sub-humid with a mean annual rainfall of 1600 mm per year, which is bimodally distributed. Long rains occur from March to August, peaking in April-May (Figure 3.2). Short rains are from September to January with a peak in October-November. The mean annual temperature is estimated to be 22⁰C. Vegetation of the Nyabeda site is similar to that of the Siaya site (see section 3.2.1).

Soils are Eutric Ferralsol (FAO/UNESCO, 1988) developed from andesites parent materials. The topsoil (0-15 cm) has a clay content of 55% and pH of 5.5 (Table 3.1). The soil is deep (>3m).

3.2.2.2 Experimental design and treatments

The experimental design was RCBD replicated 4 times with 3 root pruning treatments. The field layout is as shown in figure 3.5.

Tree species

G. robusta

Pruning treatments

1. Root pruning (one side)
2. The other side unpruned
3. Control (no root pruning on both sides)

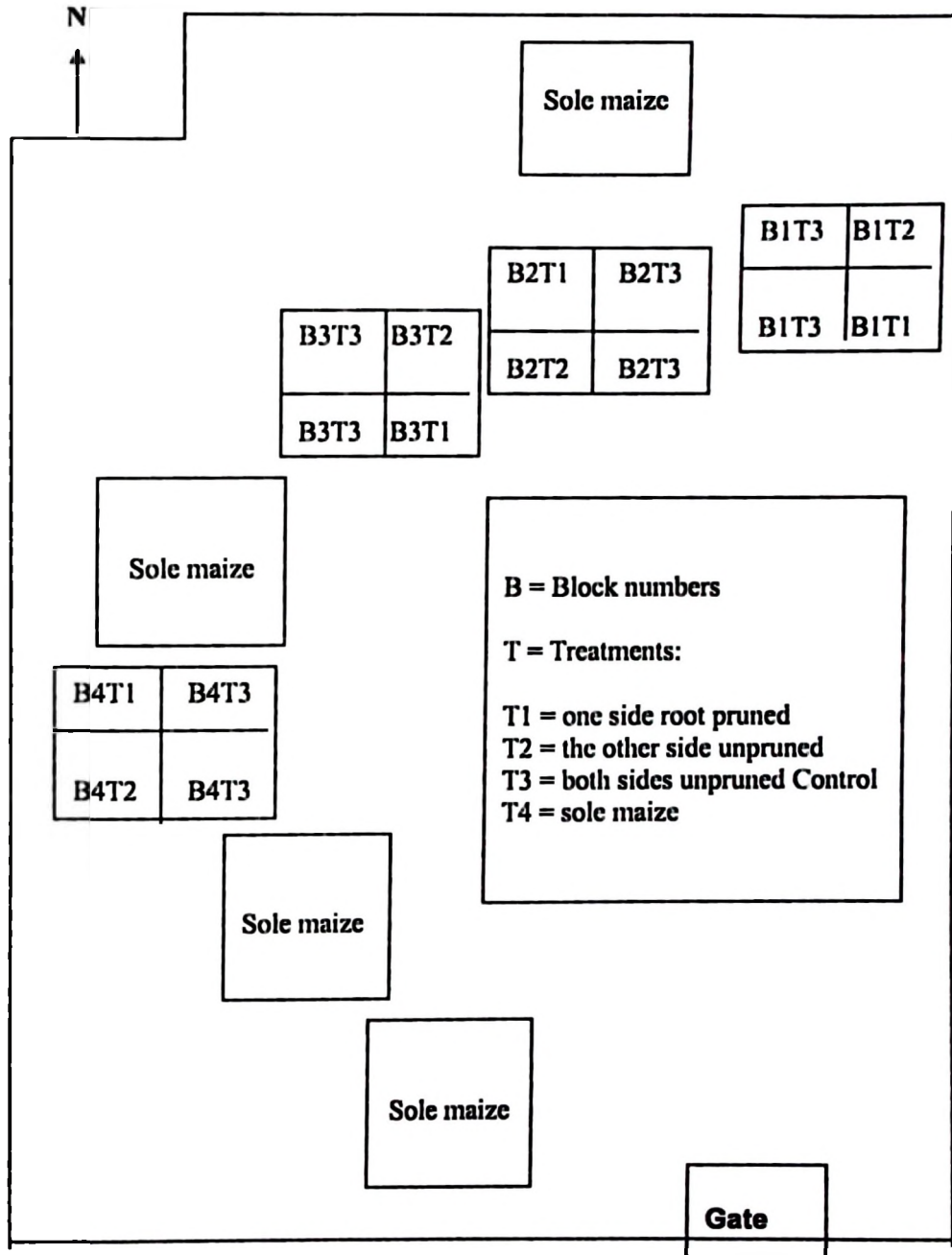

Figure 3.5: Experimental layout of Nyabeda, western Kenya

3.2.2.3 Experimental establishment

An existing experiment, originally planted for studies of “effects of trees on nutrient competition and capture” (Livesley, 1999), was used for Nyabeda experiment. Trees in Nyabeda were planted in March 1993 in a 20-m long single rows. *Grevillea robusta* was planted at 1 m spacing between trees in the row. For this study, rows were split into two sub-rows in which 10-m long tree rows were used for each treatment.

Due to bigger plot size (10 m x 10 m) tree root pruning study was extensively carried out at Nyabeda. Larger plot size also facilitated assessment of labour input for root pruning. Larger plot size may have helped to minimize interactions between plots and maximize treatment effects. A plot size of 10 m x 10 m, a block size of 20 m x 20 m, with a single row of 10 *G. robusta* trees per plot was used, and then the following treatments were imposed.

1. Root pruning (only on one side): Tree roots were cut at 30 cm radius and 30 cm depth from the base of the tree in one direction. Axe and hoes were used in root pruning.
2. Control with one side unpruned: The side in which tree roots left unpruned was monitored as different treatment and was compared with the side which was pruned.

3. Control (no pruning): Both sides of tree roots were *left unpruned for comparison.*

3.2.2.3 Field layout

The spacing used for maize was 0.75 m for inter row and 0.25-m intra row. For the purpose of comparison the rows were numbered from 1, being the nearest to the tree lines, to 10 being the farthest from the tree lines (Figure 3.6).

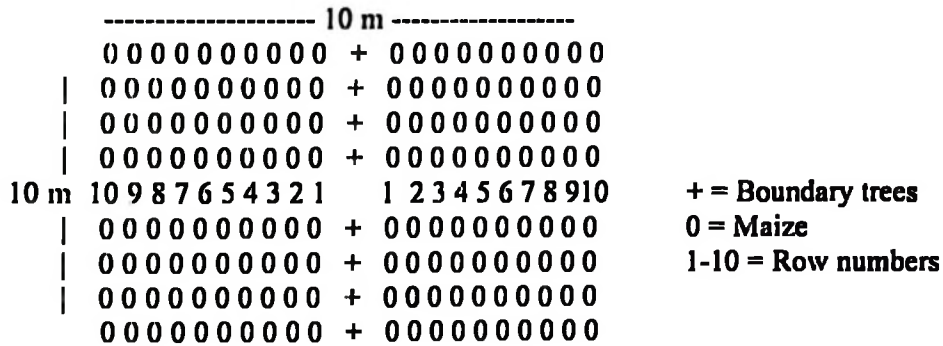

Figure 3.6: A field layout showing the arrangement of trees and maize rows in a plot at Nyabeda, western Kenya.

3.3 Establishment and management of experiments

After initial ground breaking, the land was manually cultivated according to local farming practice. The plots were cultivated with hoes (similar to mattocks) to a fine tilth when rains were about to begin. At the beginning of the first season, 1-m deep trenches were dug at margins of the sole plots in Siaya in order to stop roots of tree plots from interfering with the neighbouring sole maize plots.

The sole maize plots in Nyabeda were located at distance from tree plots and, therefore, needed no trenching. During the course of the study, there were five maize cropping seasons in Siaya and four maize cropping seasons in Nyabeda. For all cropping seasons, maize was planted in each site. Maize (hybrid 513) was cropped biannually during the long rains (March to April) and the short rains (September to January). As noted above, the maize was spaced at 75 cm between rows and 25 cm within rows giving a total population of 53333 plants per ha. There were 4 rows of maize on each side of the trees in Siaya and 10 rows on each side of the trees in Nyabeda. There were 9 rows for crop only control in Siaya and 21 in Nyabeda. Two seeds were planted per hole but were thinned leaving only one plant per planting hole at 4 weeks after planting.

Experimental plots were weeded twice per season. The first weeding was done 2 weeks and the second one 5 weeks after maize sowing. An insecticide was applied (Graduator) around trees to protect them against termites during termite attack periods. Crown and root pruning for Siaya and only one-side root pruning for Nyabeda were carried out at the start of both experiments. Triple super phosphate (TSP) 250 kg per hectare (65 kg P ha^{-1}) was applied during maize planting and urea 100 kg per hectare (46 kg N ha^{-1}) was applied 6 weeks after plantings, in all the plots on both sites in order to maximize treatment effects on variation of maize production. Both TSP and urea were applied to both sites at the start of the experiment, thereafter, TSP was applied every-other season while urea was applied every season. The application method for both TSP and urea was broadcasting all over the experimental plots.

3.4 Data collection

3.4.1 Farmer assessment

Informal and formal surveys (using structured questionnaire) were conducted in Siaya District with specific objectives of assessing farmers' tree pruning practices and their observations of tree-crop interactions on-farms. Farmers' constraints in managing trees planted with crops were also assessed. During selection of farmers for the formal survey, stratified sampling was adopted (Franzel, 1996). Within each village 5-10 farmers were selected and a total of 19 households in the district were able to participate in the formal survey. The number of farmers who participated in the informal survey was 50.

The five to ten farmers were visited randomly in the months of November, December 1999 for informal survey and in January 2000, for formal survey. Each farm visit and interview lasted between 30-45 minutes. The survey questionnaire (Appendix 1) was compiled after the informal survey was conducted in all the villages, in order to fulfil the objectives of the survey.

A household was used as sampling unit for the interviews. The interview was conducted with the head of the household, or the wife or member of the household acting as representative in decision-making. The interview exercise took about 15 days and was conducted between 9am to 5pm. Most of the interviews were in English and/or Luo (vernacular), in which the respondent was most proficient.

3.4.2 Tree growth assessment

As indicated earlier, the tree pruning experiment at Siaya was performed on an existing experiment. The objectives, methodology, and results up to 33 months after tree planting were reported in AFRENA progress reports (1997).

Tree growth in height and diameter at breast height (DBH), economic evaluations of tree pruning by farmers and pole sellers were assessed just before the pruning was applied at Siaya. Parameters such as branchiness, canopy spread and tree stem forms of the different species were also recorded.

Time taken in tree crown and root pruning were recorded and tools used in tree pruning were noted. Farmers and pole/timber traders evaluation of the quality of the species for fuelwood, construction poles and timber was also monitored by arranging farmers and pole/timber sellers visits to the experimental sites before and after pruning treatments were applied. Tree mortality, height (m), DBH (cm), crown (lateral) spread, radiation, stem form, biomass produced from pruning and tree response to pruning, by how quickly new foliage is produced following the crown pruning in Siaya, were monitored every month for the first 6 months and every 6 months thereafter for 3 years.

After pruning treatments were applied on trees in Siaya, only DBH was continued to be measured, due to the nature of the different pruning treatments applied in the test.

Some plots were crown pruned and the others were not. Lateral spread of tree canopy was scored, just before the treatments were applied visually.

Evaluation of farmers and timber merchants of tree species uses, assessments of tree growth parameters, tree performances, biomass produced from pruning and tree responses to pruning are detailed below:

Evaluation of tree species by farmers and/or pole sellers: Farmers and pole sellers were invited to evaluate, in terms of uses and market values, the tree species just before the pruning treatments were applied. Their evaluation of the different tree species was recorded accordingly.

Height in m and diameter at breast height (DBH) in cm were taken on all planted trees just before pruning treatments were applied (long rain, 1999 for Siaya and short rain 1999 for Nyabeda). Height was measured using a measuring rod to the nearest 0.1 m and DBH using a calliper to the nearest 0.1 cm.

Two diameter measurements were taken in opposite direction to reduce variability. The mean was then determined. Volume of a tree was calculated using a formula (Mwihomeke, 1990): $\text{Volume} = 1/3 \pi r^2 * h$, where $\pi = 3.142$, r = radius of the tree measured at 1.3 m height and h = height of the tree.

Branchiness was scored visually for all study trees before pruning using numerical numbers from 1 – 5. Where, 1 = very little branchiness, 2 = little branchiness, 3 = medium branchiness, 4 = branchy and 5 = very branchy.

Canopy spread was also scored visually using numbers from 1 – 5. Where, 1 = very little spread, 2= very spread, 3 = medium spread, 4 = wide spread and 5 = very wide spread.

Tree bole form was scored from 1 – 5. Where, 1 = very good, 2 = good, 3 = medium, 4 = bad and 5 = very bad. Tree bole straightness, lack of multiple leaders and/or forkiness were some of the qualities used in scoring the tree forms.

Biomass production from crown pruning: Biomass production per tree and species was taken for all species during the time of pruning. Measuring balance was used to weigh biomass production. Sample leaves and stems of pruning materials were also taken for dry weight estimation. Samples were oven dried (105⁰C) to constant weight and percentage moisture content was then calculated using the following equation:

$MC = \frac{SFW - SDW}{SDW}$; Biomass DW = (Biomass FW / MC - 1), where, MC = Moisture content, SFW = sample fresh weight and SDW = sample dry weight.

The pruned materials from the various species in the test were sun dried and given to the Institute of Technology, which is found within the experimental site. Informations (such as the amount of wood needed for cooking food (kg/hr), fire

strength and level of smoke) were noted while using the pruned materials as firewood.

Tree survival after pruning and sprouting ability of pruned trees were taken as major factors for tree responses to crown pruning. Therefore, tree survival rate was counted and tree branch sprouts were scored from 1-5, where 1 = no sprout, 2 little sprouts, 3 medium sprouts, 4 = many sprouts and 5 = very many sprouts. Branch sprout was also determined in terms of number, length and diameter at 2 years after pruning.

Measuring rods and callipers were used to measure branch length and diameter of trees respectively. This information was recorded after pruning and the data presented in this thesis are summaries of various scorings taken at various times.

Tree responses to root pruning in terms of survival and tree root re-growth was monitored on few (2 trees per species and treatments, replicated 3 times) trees at 2 years after tree pruning and was determined as percent of crosssectional area of new roots as compared to cut (old) roots of each species.

Root diameters were measured as cut and re-growth. Diameter measurements were converted to crosssectional areas for cut and new roots. The crosssectional areas of the re-growths were added together and were presented as percent re-growth compared to the cut (old) roots.

3.4.3 Soil water

Soil moisture content was determined biweekly for two years i.e. four cropping seasons in Siaya and three cropping seasons in Nyabeda. Both Theta probe (Delta T Devices, Burford, Cambridge, UK) and neutron probe methods were used in Siaya while the neutron probe was the only method used in Nyabeda.

a) Thetaprobe

Theta probe method was used to determine soil moisture content in the top 0.3 m. For calibration of Theta probe, 30 randomly selected soil samples were taken at 0-15 and 15-30 cm depth for 3 different moisture levels i.e. wet, moist and dry. All samples for the 3 different moisture levels were oven dried (105⁰C) to constant weight. Percentage moisture content was then calculated using equation 3.1:

$$\% \text{ moisture content} = ((\text{weight of moist soil} - \text{weight of dry soil}) / \text{weight of dry soil}) \times 100 \dots\dots\dots \text{Equation 3.1}$$

Percent moisture content was then regressed with the Theta-probe moisture readings to get the coefficients ∂_0 and ∂_1 for soil at Siaya. Values from the regression analysis were then fit to calibrate the readings from Theta-probe.

Volumetric water content = Theta-probe reading * 0.0387 + 7.6216. Therefore the fitted equation for relationship that has been given in the manual for Theta-probe calibration (User manual, 1998) was:

$$\text{Volumetric water content} = (1.1 + 4.44V) - \partial_0 / \partial_1$$

Where: V= Moisture readings by Theta Probe, ∂_0 (0.0387) and ∂_1 (7.6216) are constants from relationship equation found from calibration.

b) Neutron probe

Neutron probe was used because it integrates the soil moisture over a larger area than the Thetaprobe method, hence takes care of spatial variability in soil moisture content (Ong *et al.*, 1996). Therefore, soil moisture content below 20 cm soil profile was monitored by using a neutron probe (Didcot Instrument Co Ltd., Abingdon Oxon, England) at the centre of tree plots.

The neutron probe was standardized by first taking probe count reading from a drum full of water before each field-recording occasion. Aluminium access tubes (50mm internal diameter) were installed in every plot to depth of 2.1 m at 1 m and 2 m from tree lines for Siaya and at 0.3 m, 1.15 m, 2.25 m, 4.85 and 7.85 m from tree lines for Nyabeda.

Neutron probe calibration

Soil moisture calibration of the neutron probe was done gravimetrically (Bell, 1987). Volumetric soil water content (VSWC) was calculated from equation derived by using 100% water contents (in drum of full of water), actual soil counts and known soil volume and weight of cored soil samples. Using the known volume of a ring core, soil cores were removed at the same depths as those of the probe count (from 25 to 200 cm at intervals of 20 cm) and then dried in the oven to determine % water content gravimetrically (Bell, 1987).

To enable neutron probe calibration, extra access tubes were installed close to where the soil moisture probe count in the plots was being recorded. Calibration of the neutron probe was done using access tubes during the dry period. To achieve different soil water levels, the soil profile was wetted using three watering regimes of 0, 500, and 1000 litres.

Two of the access tubes received no water representing driest period. Two other tubes received 500 liters and another two 1000 litres. The use of several watering regimes provides the opportunity to increase the accuracy of estimating soil moisture counts when using neutron probe counts between dry and completely wetted soils (Bell, 1987).

Circular iron cylinders (50 cm radius) were driven into the soil (for each 20 cm soil profile up to 2 m) around the tubes to concentrate soil wetting around tubes. Wetting was done for 2 days and afterwards probe counts were made for all calibration tubes. Before taking probe counts in the extra calibration tubes, the drum water count was recorded. The neutron probe counts were divided by 100% water count to provide water count ratios at each soil depth.

From a trench of 2 m depth made on one side of the access tubes, soil cores for gravimetric water determination were taken down the profile at the same soil depth interval as those of the neutron probe counts. That is, at 20, 40, 60, 80, 100, 120, 140, 160, 180 and 200 cm of soil depths. The soil depths presented here are the real soil depths after correcting for the depth (15 cm) from the top of the access tube.

Known soil volume was obtained by using metal cylinders measuring 5 cm diameter and 5 cm length. The cylinders were driven carefully into the soil profile walls to extract undisturbed soil core samples at approximately the same depths as those used in the recording of the probe counts. The extracted wet cored soil samples were tightly sealed using plastic paper and weighed. Their dry weights were obtained by oven drying at 105^o C to constant weight. Volumetric soil water content was calculated directly as weight of water per unit volume of soil contained in sample cylinders. The percentage water content in sample rings was converted into volumetric soil water content by multiplying with soil bulk density (1.13 g cm⁻³ for both sites). Regression of probe counts ratios to volumetric soil water content provided the equation for converting probe count into volumetric soil water content.

Two separate calibration regression equations for neutron probe for 20-130 cm and 140-210 cm were used because (i) the neutron probe count sphere during dry periods may exceed the surface soil horizon into the atmosphere and (ii) in some plots hardpan and gravel occurred within less than 100 cm depths, thus having different soil texture between surface and deeper soils. For instance, Bell (1987) cautions that neutron probe sphere of influence in dry soils exceed 30 cm and therefore counts near the soil surface may give inaccurate readings due to loss of some neutrons into the atmosphere. Therefore using one calibration equation for both surface and at depth of soil layers might exaggerate the soil moisture situation at the surface. Neutron calibration was performed for each site separately as recommended by Bell (1987).

Regression equations of volumetric soil water content (\emptyset) to probe count ratio.

Siaya:

a) Volumetric water content (\emptyset) 20-130 cm depth:

$$(\text{Probe count/Water count}) * 43.35 + 13.325 \dots\dots\dots \text{Equation} \quad 3.2$$

b) Volumetric water content (\emptyset) 140-210 cm depth:

$$(\text{Probe count/Water count}) * 30.67 + 17.205 \dots\dots\dots \text{Equation} \quad 3.3$$

% Volumetric water content:

$$\text{Bulk density} * \% \text{ gravimetric water content} \dots\dots\dots \text{Equation} \quad 3.4$$

Nyabeda:

a) 20-130 cm depth:

Probe count/Water count * 66.668 + 1.4565 Equation 3.5

b) 140-200 cm:

Probe count/Water count * 48.191 + 10.211 Equation 3.6

% Volumetric water content:

Bulk density * % gravimetric water content Equation 3.7

Rainfall canopy throughfall

Rain throughfall under the crown pruned and un-pruned (control) trees of *G. robusta* and *C. equisetifolia* were quantified during the 3rd, 4th and 5th seasons of the Siaya experiment. This was done in block 1 and 2. Two rain-gauges were installed in each plot at the centre of the plot at one and two meters from tree lines on only one side of the plots.

Another two rain-gauges were also installed outside the plots, with no tree interference. This measurement gave an estimate of how much rainfall was received without being intercepted by trees. At all times, measurements were made after a rainfall event during the day.

3.4.4 Sap flow

Sap flow is water and solute movement in the phloem. Sap movement in the plants is correlated with transpiration rates (Zang *et al.*, 1996; Cohen *et al.*, 1993). The heat balance and heat pulse methods have been described as the best for estimating transpiration in AF systems (Khan and Ong, 1996; Hatton *et al.*, 1990). After evaluating the two methods, Cohen *et al.* (1993) recommended the use of heat pulse to estimate transpiration of bigger trees in the field rather than the heat balance method because of systematic errors encountered with the latter in estimating transpiration of bigger trees. For this reason, the heat pulse method was used to estimate transpiration rates of *C. equisetifolia* and *G. robusta* tree species used in this study.

Sap flow or transpiration per tree by treatments (in cm^3h^{-1}) was measured using heat pulse gauges manufactured at ICRAF based on the QM-54 heat pulse design (Khan and Ong, 1996). Heat pulse gauges consisted of a 38 ohms heater and two sensor probes. The sensor probes were embedded in the xylem of the pruned and unpruned trees. Positioning sensors at different depths into the stem tissue had taken into account the variability in sap flux density between the cambium and heartwood (Hatton *et al.*, 1995). Heat pulse gauges were connected to a datalogger (CR21X, Campbell Scientific, Leics) to record the velocity of the heat pulse every 30 minutes.

Heat velocity (V) was calculated using Equation 3.8 (Marshall, 1958):

$$V_h = (X_d - X_u) / 2t_o \text{ (mm/min)} \dots\dots\dots \text{Equation } 3.8$$

Where X_d and X_u are distances of the downstream and upstream sensors from the heater, and t_o is the time between the release of the heat pulse and the equilibration of temperature between the upstream and downstream sensors.

In order to measure total transpiration, heat gauges were installed on the stem of each tree being monitored (3 trees per treatment). Three trees per treatment were wired at the same time, each with 3 sets of probe gauges thus allowing nine probes at each recording. Because of the probes' limited wire length, only three closely planted trees could be used.

The heat probes were inserted into the trees through pre-drilled holes (Figure 3.7). The holes were drilled with help of a guide jig block that contained holes spaced at the appropriate distances for probe spacing (Khan and Ong, 1996). The probe needles were embedded into trees at height of 1.2 m and the diameter of the stem at this height was measured. The drilling was carefully done to avoid disturbing the tissues and tilting from horizontal drill line.

Each sensor probe is made of thermocouples placed at 0.5 cm, 1.5 cm and 2.5 cm from the tip. The sensor probe pair is placed in vertical plane to measure sap flow velocities upstream and downstream at 0.6 cm below and 1.6 cm above the heater probe respectively (Figure 3.7). Drilling through a deformed part of the stem was also avoided. After inserting the heat gauges, aluminium foil was used to cover the needles to reduce effect of ambient temperatures from interfering with that measured by the probes. Sap flow monitoring was carried out during the 2nd cropping season for Nyabeda and 3rd and 4th cropping seasons for Siaya, for 10-15 days. Due to the limitation of the availability of Sap flow equipment, only two species (*C. equisetifolia* and *G. robusta*) were included in this study.

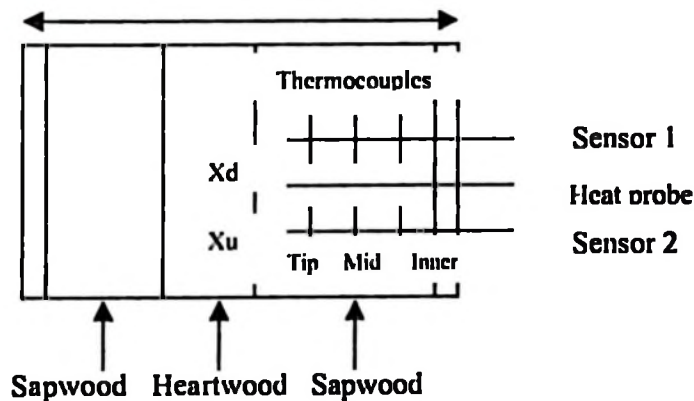

Figure 3.7: Illustration of a set of heat pulse gauges inserted into a stem of diameter D and indicating sapwood and heartwood proportion.

X_d and X_u are predetermined distances downstream between sensor 1 and the heater probe and upstream between sensor 2 and heater probe for calculating sap velocity respectively. The tip, middle and outer thermocouple positions on the probe sensor are indicated (Khan and Ong, 1996).

Sap flow calculations

Heat pulse velocity was converted to sap flux density (the volume of sap moving in the stem per unit cross sectional area per second) using equation 3.9:

$$V_s = V_h (P_{sm} C_{sm}) / (P_s C_s) \dots\dots\dots \text{Equation 3.9}$$

Where V_h = heat velocity

P_s = density

C_s = specific heat capacity of sap

P_{sm} = density of green wood

C_{sm} = specific heat capacity of green wood.

It is assumed that density and specific heat capacity of sap are equal to that of water. The volumetric proportions of wood and water were determined before P_{sm} and C_{sm} was estimated as described by Edwards and Warwick (1984).

For each treatment, Sap flow (Q) or transpiration per tree (in cm^3h^{-1}) was calculated by integrating the product of sap flux density at each sensor position and its respective cross sectional area of conducting wood (A) (Green and Clothier, 1988). Thus, for a tree of radius under bark (r) and heartwood radius (h) the cross sectional areas sampled by sensors at the three depths were calculated in equation 3.10 through 3.13:

$$\Lambda_1 = \pi r^2 - \pi (r-1)^2 \text{ for sensor closest to the cambium Equation 3.10}$$

$$\Lambda_2 = \pi (r-1)^2 - \pi (r-2)^2 \text{ for the second sensor Equation 3.11}$$

$$\Lambda_3 = \pi (r-2)^2 - \pi h^2 \text{ for the deepest sensor Equation 3.12}$$

$$\text{Therefore, } Q = V_s \cdot \Lambda \text{ Equation 3.13}$$

Where, Q = sap flux, V_s = sap flow velocity and Λ = wood conducting area ($\Lambda_1 + \Lambda_2 + \Lambda_3$), $\pi = 3.14$.

Three trees of the same size under each species and site were used simultaneously in the test during each measurement occasion. At the time of the sap flow measurement, mean DBH of *C. equisetifolia* was 8.23 cm and that of *G. robusta* was 9.11 cm at Siaya while that of *G. robusta* at Nyabeda was DBH of 12.73 cm. Sample trees used in Sap flow measurement exhibited similar DBH at both sites. The sap velocity data was averaged in half hourly interval for each probe thermocouples and stored in the datalogger.

3.4.5 Fractional light interception measurements

To determine the shading effect of the upper-story trees on the under-story maize crop in Siaya, light interception measurements were done during the four cropping seasons when maize was planted in the trial. The fraction of incoming photosynthetically active radiation (PAR) incident on the maize crop and the fraction intercepted by the maize canopy were measured during these seasons.

Light interception was measured using a sun fleck ceptometer. Ten measurements in each plot, replicated 3 times, were taken (at the height where leaves are green) by holding the ceptometer perpendicular to the rows. On every occasion, the fraction of incoming photosynthetically active radiation (PAR) incident on the maize crop and the fraction intercepted by the maize canopy were taken between 1200-h and 1400-h local time, every two weeks for two years. The above and below maize canopy measurements were used to determine fractional light interception by maize crop. Interception of PAR was estimated by the equation 3.14:

$$\text{Fractional intercepted PAR} = 1 - (\text{PAR below canopy} / \text{PAR above canopy})$$

Stigter and Musabilha, 1982 Equation 3.14

The fraction of incident photosynthetically PAR reaching the maize crop canopy and the fraction intercepted by it were then calculated for each treatment on row by row basis. For detailed data assessment information for Siaya and Nyabeda sites, please refer to Tables, 3.2 and 3.3 respectively.

3.4.6 Maize growth and yield

Growth measurement of maize crop commenced two weeks after maize emergence. Height (cm) of the middle ten maize plants, in each row were measured every two weeks. Height was measured using a height measuring pole to the nearest 0.1 m, and root collar diameter (10 cm above ground) using small calliper to the nearest 0.1 cm. Standing maize plants and cobs were counted row by row just before harvesting, in

order to be able to evaluate trends of maize yield with distance from the tree line. Thereafter maize was harvested and kept separately for each row. Cobs and stover fresh weight (kg) were also recorded for each row. Sub-samples of cobs and stovers from randomly selected rows of each treatment were taken and oven dried to determine grain and stover dry weight yields respectively. The oven-dried sub-samples of cobs were shelled manually to determine grain weight.

Threshing percentage was calculated using the equation 3.15:

$$\text{Threshing \%} = (\text{Grain weight} / \text{cob fresh weight}) \times 100 \dots \text{Equation 3.15}$$

Grain yield per row/plot was determined using the equation 3.16:

$$\text{Grain yield (kg)} = \text{cob fresh weight} \times \text{threshing \%} \dots \dots \dots \text{Equation 3.16}$$

Maize growth and yield studies were undertaken in five cropping seasons for two and half years in Siaya and in four cropping seasons for two years in Nyabeda. Effects of tree pruning on maize yields were studied by comparing growth and yields of maize, with and without tree pruning treatments for both sites.

The maize yield in both Siaya and Nyabeda were obtained from harvesting the mature maize cobs in the plots at specified maize rows on both sides of the tree lines during the five cropping seasons.

3.5 Data management and analysis

3.5.1 Farmers' survey

The data collected from the questionnaire were coded and keyed in a computer using excel and then transferred to SPSS 6.0, computer program for Windows (Erlbaum, (UK). Since most of the data were qualitative, frequency distribution of responses were examined using descriptive statistics and none parametric tests, such as Chi-square tests (for both tests of goodness or fit and tests of association).

3.5.2 Experimental data

For each experiment (site), inferential statistics was used to analyze tree, maize, moisture and light parameters. Analysis of variance (ANOVA, Tables 3.4 and 3.5) was used to test the differences between treatments for tree survival (data subjected to arc sign transformation prior to ANOVA), tree height, tree DBH, tree volume, crown spread, stem form, biomass produced from pruning, re-coppicing ability of crown pruned trees, time spent in pruning trees, changes in water content, rate of changes in sap flow or transpiration, fractional radiation intercepted by trees and crops and maize yield in terms of cobs dry weight and grain yield.

For ANOVA, a probability of 0.05 or less was accepted as indicating that treatment effects were occurring. If significant effect did occur, means were separated by Fisher's Least Significant Difference (LSD) method (Chew, 1977).

Regression analysis was used to determine correlations and their coefficients. Then mean ANOVA outputs of these results were transformed back to their original units. Mean scores and rankings of qualitative data were rounded to the nearest figures.

In addition to the main experimental design, different data analysis methods and approaches were involved depending on the design of the experimental level and objective of the comparison. Analysis of variance (ANOVA) was used to compare the effect of tree pruning treatment on crop yield at each experimental level. An experimental unit is defined as a single unit in which a treatment is applied and these were:

1. **Main plot:** where treatment means of e.g. Height, DBH, biomass from tree crown pruning are compared. It is also applicable where overall treatment effect on crop yields or soil moisture is compared at the plot level.
2. **Subplot:** where effects of tree on soil moisture or crop yields are compared between treatments at fixed distances from tree rows. This is necessary when evaluating the interactions between trees and distance on soil moisture, crop yields or crop growth.
3. **Sub subplot:** where soil water at different soil depths is compared between treatments at each fixed distance from the tree lines. This is also necessary when evaluating interactions between tree pruning treatments, distance and depth.

Microsoft Excel and Genstat 5 release 4.1 (Rothamsted Experimental Station) program for Windows were used for preparation of data summaries and analysis.

Because of the need not only to compare treatment difference but also interactions between tree species, treatments, distance and depth the structure of data analysis was treated as split plots in the main treatment plots (Mead *et al.*, 1993). For example: Crop growth and yield measurements for each sampling occasion for whole plots were compared between treatments by ANOVA.

Crop growth and yield measurements for each sampling occasion for whole plots were compared between species and pruning treatments by ANOVA. Since repeated measurements were carried out for crop yield, split-plot analysis of variance was used to establish differences between species and treatments at each measuring occasion.

The interaction between species, pruning treatments and distance was examined with, each distance from tree rows treated as a sub subplot. Least significant differences (Lsd) were determined when Fisher's F-test was significant. The relationship between maize grain yield and distance from tree lines at both sites were tested by regression analysis.

Table 3.2: Details of assessments made during the course of the study for Siaya Experiment, western Kenya.

Variables measured	Season of assessment	Nature of assessment and comments
Farmers survey	1 st	Farmers tree planting and tree pruning practices on farms in western Kenya
Farmers and timber sellers assessment of species at Siaya	1 st and 2 nd	Farmers and pole/timber sellers preferences of tree species grown at Siaya site for fuelwood, poles, timber and price estimate of those species if being sold by farmers or timber sellers
Tree parameters	1 st , 2 nd and 4 th	Height, DBH, bole form and crown scoring
Tree biomass (1 st pruning)	1 st and 2 nd	Tree biomass fresh weight in kg and dry weight in kg
Time spent in tree pruning	1 st	Time spent in crown and root pruning per tree per person
Tree responses to pruning	1 st and 2 nd	Survival, shoot coppice and number of coppice and DBH
Maize growth and yield	1 st and 2 nd for growth, 1 st , 2 nd , 3 rd , 4 th and 5 th for yield	Height, root-collar diameter and cobs and grain yields
Moisture	1 st , 2 nd , 3 rd and 4 th	Soil moisture readings by theta-probe and neutron probe
Sap-flow	3 rd and 4 th	Rate of transpiration per tree per hr for the pruned and unpruned trees
Light	1 st , 2 nd , 3 rd and 4 th	Light assessment using ceptometer
Rain-fall canopy interception	2 nd , 3 rd , 4 th and 5 th	Rainfall measurements under crown pruned and unpruned trees as well as in the open air for comparison

Note: 1st season = March-August 1999 (long rains), 2nd season = September-February 2000, (short rains 2000), 3rd season = March-August 2000, 4th season = September-February 2001, 5th season = March-August 2001.

Table 3.3: Details of assessments made during the course of the study for Nyabeda Experiment, western Kenya

Variables measured	Season of assessment	Nature of assessment and comments
Tree parameters	1 st , 2 nd and 3 rd	Height, diameter
Time spent in tree root pruning	1 st	Time spent in root pruning per tree per person
Tree responses to root pruning	1 st , 2 nd and 3 rd	Survival and effects on height and DBH
Maize yield	1 st , 2 nd , 3 rd and 4 th	Cobs and grain yields
Moisture	1 st , 2 nd , 3 rd , and 4 th	Soil moisture readings by neutron probe
Sap-flow	2 nd	Transpiration per tree per hr for the root pruned and unpruned trees
Light	3 rd	Light assessment using ceptometer

Note: 1st season = September-February 2000 (short rains 2000), 2nd season = March-August 2000 (long rains 2000), 3rd season = September-February 2001, 4th season = March-August 2001

Where similar repeated measurements are involved (e.g. crop yields, soil moisture, light etc.), residuals from the neighbouring sample units are likely to be more closely correlated on any measuring occasion than those measured at different times or those measured at the same times but further away.

In such cases assumptions made for ANOVA (that sample units are random, error terms are normally distributed, homogeneity of variance and additively effects occur in linear model) are violated and become invalid in estimating existing error. Other data analysis methods such as split plot analysis, regression analysis and least

significant difference of means (Lsd) were adopted, as appropriate (Mead *et al.*, 1993).

In most cases repeated measurements were treated as split plots at each measuring occasion since they were repeated in intervals in space and time (Mead *et al.*, 1993). Although there are many ways of analyzing repeated measurements such as multivariate analysis, which is rather complex, split-plot analysis was recommended for similar studies (Mead *et al.*, 1993).

Furthermore, where effects of tree on crops or soil moisture were compared at specific times and space, summaries of data for each variable were made and tested by regression analysis.

Where individual tree species growths such as height, DBH and volume of stem are summarized standard error of the means were used to test variations between individual values or means of tree species.

Specifically, to compare the effect of treatment on crop yields or soil moisture at plot level, ANOVA was appropriate for these comparisons between treatments. To compare relationships between crop yields and soil moisture or rainfall and crop yields or crop yields with rainfall, regression analysis was appropriated (Mead *et al.*, 1993) where independent variables (such as rainfall) were correlated with dependent variables (crop yields or soil moisture etc.).

Table 3.4: Structure of the ANOVA comparing the different Treatment at Siaya.

4 x 4 factorial design with different ANOVA analysis approaches (Random/split plot analysis)	
Source of variation	Degrees of freedom (df)
Trees/Sap flow: Random; Block = Block/plot & Treatment = Species x Treatment.	
Block (B)	2
Species (S)	3
B x S	6
Treatment (T)	3
B x T	6
S x T	9
Residual error	14
Maize/Light: Split/split plot; Block = Block/ main plot plot/sub-plot & Treatment = Sole maize/(Species x Treatment x Maize Row)	
Block (B)	2
Species (S)	3
B x S (error-1)	6
Treatment (T)	3
S x T	9
B x T	6
B x S x T (error-2)	18
Row (R)	3
B x R	6
S x R	9
T x R	9
S x T x R	27
Residual error	38
Soil water: Block = Block/main plot plot/sub-plot & Treatment = Sole maize/(Species x Treatment x Distance x Depth)	
Block (B)	2
Species (S)	3
B x S	6
Treatment (T)	3
S x T	9
B x T	6
B x S x T	18
Distance (D)	1
B x D	2
Depth (P)	8
B x P	16
S x D	3
S x P	24
T x D	3
T x P	24
S x T x D	9
S x T x P	72
S x T x D x P	32
Residual error	90

Table 3.5: Structure of the ANOVA comparing the different Treatment at Nyabeda.

RCBD design with different ANOVA analysis approaches (Random/split plot analysis)	
Source of variation	Degrees of freedom
Trees/Sapflow: Random; Block = Block/plot & Treatment = Treatment.	
Block (B)	3
Treatment (T)	2
B x T	6
Residual error	9
Maize: Split plot; Block = Block/plot & Treatment = Sole maize/(Treatment x Maize Row)	
Block (B)	3
Treatment (T)	2
B x T (error-1)	6
Row (R)	9
B x R	27
T x R	18
Residual error	36
Soil moisture: Split/split plot; Block = Block/main-plot/sub-plot & Treatment = Sole maize/(Treatment x Distance x Depth)	
Block (B)	3
Treatment (T)	2
B x T (error-1)	6
Distance (D)	4
T x D	8
B x D	12
B x T x D (error-2)	24
Depth (P)	9
B x P	27
T x P	18
T x D x P	72
Residual error	72

At sub plot level (e.g. at specific distance from tree lines or rows), effect of the interactions between trees and distance on crop yields or soil moisture was tested by ANOVA at each distance. However, regression analysis between yields or moisture summaries with distance was also done.

To separate effects arising from the presence of trees as opposed to those resulting from differences between tree treatments, a factor, named "sole maize" was included to distinguish plots containing trees from those lacking trees.

Furthermore, since the sole maize plots lacked corresponding distances from trees, treatment comparison with sole maize to determine trees effects was carried out when contrasting tree pruning treatments with sole maize at each sample distance using ANOVA.

At a sub subplot level (soil depth at specific distance), soil moisture at each depth was regressed with depth.

In summary, ANOVA was used to compare interactions between species, treatments, distance and depth effect on soil water content. Contrasting of individual species and pruning treatments with the control sole maize plots was carried out at each distance to determine the effect of trees on soil moisture at different distance from the trees.

The repeated measurements of soil water were analyzed separately for each measuring occasion as split plots and compared with least significant differences of means (Lsd) between species and treatments, when Fisher's F test indicated that differences were significant.

Because the sole maize plots had no trees, the results presented here comparing species and treatments with sole maize plots at different distance from trees, are made when each particular distance from trees is treated separately as an entity and then compared with soil water in the sole maize plots.

Data was grouped and merged according to the changes in rainfall during the long and short rains of measurement seasons. And, therefore, data was summarized for April-May (long rain-wet), June-July (long rain-dry), October-November (short rain-wet) and December-January (short rain-dry).

CHAPTER FOUR

4.0 RESULTS

Chapter 4 presents the results of the different outputs and research findings at both Siaya and Nyabeda sites. The chapter is subdivided into different sections for the specific sub- studies undertaken. Section 4.1 presents results of farmers' survey while results of tree growth and biomass produced are presented in section 4.2. Section 4.3 presents results of soil water under different trees and pruning treatments while section 4.4 deals with results of sap flow or water movement in the trees, in relation to the different treatments. Results of light interception in boundary planting are presented in section 4.5 while Section 4.6 deals with results of maize growth and yield in relation to the different pruning treatments.

4.1 Farmers' survey

A survey of farmers' tree pruning practices in Siaya District, western Kenya, was undertaken. Results from these surveys were used in the planning of tree-crop management studies at Siaya and Nyabeda, western Kenya. The baseline information based on the formal survey at Siaya has been processed and results are presented in this subsection. The survey results are categorized under different sub-sub sections. These include household characterization, farmers' tree planting and niches for tree planting, farmers' tree management practices and their observation of tree-crop interactions on farms and farmers' constraints in tree planting and management.

4.1.1 Household characterization

The decision on the farm and household activities was in most cases made by men while women made decisions when their husbands' were away or dead. Decision making by both men and women was noted in few cases (Table 4.1.1). Age class of the decision-makers ranged from 31 to > 70 years, although, the most frequently observed age class of decision-makers was between 31 and 40 years.

The second most frequently observed age class of the decision maker was from 51-60. Almost all (96%) decision-makers of the household have primary or adult education. Most households (89%) obtained household incomes from their farms. All (100%) respondents own their land. The average size of land holdings per household according to the 1993 Siaya District plan was 1.4 hectares, however, this survey found it to be 2.1 hectares.

Table 4.1.1: Farm/household decision makers in Siaya, western Kenya.

Category	N	% respondents
Male headed	14	73.7
Female headed	3	15.8
Both men and women	2	10.5
Total	19	100
F-pr	0.001	0.001

N = Number of farmers interviewed, F-pr = Probability value from chi square test.

4.1.2 Tree planting, niches or patterns of tree planting on farms

Trees are found on farm boundaries, home compounds, scattered in crop lands and woodlots. Niches for trees on farms were identified as homestead, hedgerow in cropland, internal and external boundaries (Table 4.1.2). Farmers who planted trees along agricultural fields observed shading effects on crops. Tree planting varied with planting arrangements among farmers. Some (36.8%) farmers planted trees in lines while others (10.5%) planted in both scattered and line arrangements (Table 4.1.3).

Table 4.1.2: Niches for trees used by respondents in Siaya, western Kenya.

Category	N	% respondents
Homestead/woodlot	9	47.4
Hedgerow in crop land	7	36.8
Internal and external boundaries	3	15.8
All	10	52.6
Total	29*	152.6*
F-pr	0.001	0.001

N = Number of farmers interviewed, F-pr = Probability value from chi square test.
* 'N' and % respondents are added more than 19 and 100% respectively as farmers used more than one niche for planting.

Table 4.1.3: Tree planting arrangements in Siaya, western Kenya.

Category	N	% respondents
Line	7	36.8
Scattered	7	36.8
Line and Scattered	2	10.5
All	1	5.4
No response	2	10.5
Total	19	100
F-pr	0.001	0.001

N = Number of farmers interviewed, F-pr = Probability value from chi square test.

4.1.3 Purpose of tree planting on-farms

Farmers in Siaya District grow trees mainly for fuelwood, construction poles, timber, shade, windbreak, boundary demarcation, fencing, fruits, beautification, cash generation, and medicine. The most important and widely found and/or grown tree species in Siaya are *M. lutea*, *Eucalyptus* spp, *G. robusta* and various fruit trees. Farmers responses to the categories of tree species planted were grouped as exotics and indigenous species (Table 4.1.4).

Indigenous species are normally found on-farm and were probably the result of natural generation. Farmers couldn't tell whether or not their parents or grandparents planted tree species such as *M. lutea*. What they know is, when they inherited the land the trees were already there and, therefore, continued using the trees as their parents and grandparents did in the past.

Table 4.1.4: Categories of tree species planted on-farm in Siaya, western Kenya.

Category	N	% respondents
Indigenous tree species only	1	5.3
Exotic tree species only	0	0
Exotics and fruit tree species	3	15.8
A mixture of indigenous tree species exotic tree species and fruit trees	15	78.9
Total	19	100
F-pr	0.001	0.001

N = Number of farmers interviewed, F-pr = Probability value from chi square test.

4.1.4 Tree pruning (management) practices

Seventy-four percent (74%) of the farmers in Siaya grow/have *M. lutea* in their farms. Farmers grow intercrop maize crop with trees. They, however, observed tree-shading effects on crops by comparing crop yield close to the trees and away from the trees (Table 4.1.5). Eighty-four percent of the respondents observed that crop yields that are close to trees were very low compared to crops that are far away from the trees while 8% said yields are the same. Eight- percent of the respondents could not answer the question.

Most farmers pruned pole/timber species such as *G. robusta*, *E. grandis* and *M. lutea* trees to reduce shading problems on adjacent crops, to improve stem quality and get wood for household needs. The most common type of pruning observed is pollarding *M. lutea* trees. Most farmers in Siaya cut *M. lutea* at the base of the trees for coppicing.

Most farmers do not prune fruit trees and trees planted as fences (Table 4.1.5). They claimed that pruning fruit trees will reduce production, however, lower branches are removed for easy access. Some farmers did not completely remove the branches from the tree stem. They said this will ease next climbing for more pruning to take place. They also mentioned that this helps trees to sprout faster.

Men did the pruning in 57.9% cases while young boys pruned in 10.5% cases. Women pruned young and accessible trees in 15.8% cases. Hired labour has been used in 5.3% cases and 10.5% cases were reported for all family members' participation in tree pruning.

Table 4.1.5: Summary of farmers tree pruning activities in Siaya, western Kenya.

Category	N	% respondents
Degree of shading effects		
- Heavy shading	13	68.4
- Light shading	3	15.8
- Could not tell	3	15.8
Total	19	100
F-pr	0.001	0.001
Reasons for pruning		
- Reduce shading on crops	3	15.8
- Get firewood & construction materials	2	10.5
- Improve wood quality and growth increment	3	15.8
- All (shade, fire wood, construction poles and improve wood quality)	11	57.9
Total	19	100
F-pr	0.001	0.001
Reasons for not pruning		
- Get more fruit production	9	47.4
- Shade for human and animals	1	5.3
- Protection against wind and encroachment	2	10.5
- No time and labour to prune	3	15.8
- No response	4	21.1
Total	19	100
F-pr	0.001	0.001

N = Number of farmers interviewed, F-pr = Probability value from chi square test.

Respondents who said women don't prune trees gave various reasons. Fifty-eight-percent of the respondents did not know why women are not allowed to prune trees while 21% respondents said it is just a tradition. Sixteen-percent of the respondents reported that pruning is a difficult job for women. Five-percent of the respondents mentioned lack of ownership on trees. They said trees are for men and only men have the right to do whatever they want do with their trees, including tree management.

Respondents who employed labour for pruning paid a range of 0.16-0.56 US\$¹ per tree, depending on the size, age and species. On average the cost of pruning was reported to be 0.35 US\$ per tree. Almost all (94.7%) farmers observed sprouting of *M. lutea* trees after pollarding.

4.1.5 Uses of pruning materials

Most farmers used tree prunings as firewood (47.1%) and bigger branches for building houses (20.6%). Farmers with surplus product of prunings sold out the wood (26.5%). Some farmers left tree branches on farm as mulch and manure (5.9%).

A bundle of fuelwood was sold, on average, for US\$ 0.64 in near market and/or on-farm. All (100%) farmers used the income from pruning sales for household needs.

¹ 1 US\$ at the time of the survey was about 63 Kenyan or 1000 Tanzanian Shillings .

4.1.6 Time of pruning and tools used in tree pruning

Almost in all cases (100%) farmers pruned or would prune their trees on-farms just before the planting season. They said trees will have time to utilize the coming rain for growing faster, avoid tree-shading effects on planted crops and damage caused during pruning. Pruning before the rain was also preferred, as farmers will be busy planting crops during the rain. Some (47%) farmers also indicated the importance of drying firewood in the sun and justified the need to do the pruning during the dry season.

Most farmers used machetes (pangas) to prune trees (84.2%). Very few farmers used both machete and saw (10.5%) and saw only (5.3). Ladder was used by most respondents for climbing taller trees (90%). Ten-percent of the cases were reported using various techniques such as climbing. Farmers start pruning when trees are young (6-12 months) and continue pruning depending on the species, size and age of the trees. Five-percent of the respondents said that they would prune their trees every 6 months (every season), while most (58%) said every year. Thirty-seven-percent said it depends on the species, size and age. Few (5.9%) respondents said they would prune every 2 years or more. Less commercially valuable species are not pruned as frequently as commercially valuable species. Fruit trees were also not usually pruned as farmers assume that pruning fruit trees would reduce fruit production. The time spent in branch or crown pruning varied from respondents to respondents (Table 4.1.6).

Table 4.1.6: Time spent on tree pruning (per tree) in Siaya, western Kenya.

Category	N	% respondents
Less than 30mins	11	57.9
30-60mins	3	15.8
Depends on species, age and size of trees	3	15.8
Don't remember	2	10.5
Total	19	100
F-pr	0.001	0.001

N = Number of farmers interviewed, F-pr = Probability value from chi square test.

4.1.7 Farmers' observations of tree-crop interactions due to crown shading and root competition with crops

Ninety-percent of the farmers observed positive changes on crops after crown pruning and, therefore, farmers are aware of the competition for shade and water when trees are grown in close proximity with agricultural crops. They, however, still found crops with trees to perform relatively less compared to the crops without trees. Most farmers (76%) suspect the problem as root interference with crops.

Although farmers observed tree root competition with crops, most (68.2%) of them did not take any measure to manage the problem. This is because they did not know what to do with such problems. They think root management needs special skill, more time, money and labour. Very few (4.5%) farmers used trenches to avoid tree root spreading into the crop fields. Some (27%) farmers believed to have disrupted the tree roots, unknowingly, which might have grown into crop fields while preparing the land for planting crops.

4.1.8 Farmers' observations on tree responses to pruning

All most all (95%) respondents, who pollarded their trees, observed sprouting of pollarded trees, and few (5%) observed faster growth increment in both height and diameter of side pruned trees. Twenty-one percent of them said trees had both sprouted and grew faster. Note that percentage response is added to more than 100% as respondents gave more than one opinion.

4.1.9 Farmers' observations of soils under trees after pruning

Farmers observed rich soils under trees, though not scientifically proved (Table 4.1.7). Farmers made the observations using soil colour, soil moisture and crop performance. Most farmers (90%) preferred to grow indigenous species such as *M. lutea* along crop boundaries than exotic species and they argued that soils under indigenous species are more fertile than soils under exotic species.

Table 4.1.7: Farmers' evaluation of soils after tree pruning at Siaya, western Kenya.

Category (which one is more fertile?)	N	% respondents
Soils close to trees	17	89.5
Soils far from trees (> 2m)	0	0
No difference	2	10.5
Total	19	100
F-pr	0.001	0.001

N = Number of farmers interviewed, F-pr = Probability value from chi square test.

4.1.10 Farmers future plans and constraints in growing trees on their farms

Farmers expressed their interest in growing more trees in the future. Almost all (100%) of them requested if there is any assistance given by any institution in getting them seeds and/or seedlings for planting. Most (85%) farmers further asked for support of pesticides and advise on tree management, to reduce competition with crops. Pests, shortage of labour during peak seasons, competition of trees with crops, lack of tree seeds and seedlings are some of the major constraints identified by farmers.

4.1.11 Farmers and pole/timber merchants evaluations of tree species just before trees were subject to pruning at Siaya

Although, *M. lutea* recorded the least performances in both growth and stem form in this study it was still the most preferred species by farmers and pole/timber merchants. Poles, timber, charcoal, fuelwood, furniture, ornamental and intercropping were some of the farmers benefits obtained from *M. lutea*. The second most preferred species was *E. grandis* followed by *G. robusta* and *C. equisetifolia*. *E. grandis* was preferred for poles, fuelwood, timber and furniture. However, farmers would intercrop this species if they could only prune the trees regularly, otherwise they would prefer to plant it as a woodlot in places where crops are not grown.

Farmers said they would intercrop *M. lutea* and *G. robusta* because, according to them, the two species won't compete with crops. They also believe that intercropping *M. lutea* would in fact increase crop yield. *G. robusta* was preferred for timber,

poles, fuelwood and other domestic uses. Farmers would only use *C. equisetifolia* as ornamental and shade tree around homesteads because they are not familiar with the species.

The price of 48 months old *M. lutea*² was estimated to be between 0.24 and 0.63 US\$ per tree. The cost of cutting at this stage was estimated to range between 0.05 and 0.08 US\$ per tree. Farmers estimates for the *E. grandis* price ranged between 10.32 and 28.57 US\$ per tree. Labour cost for cutting *E. grandis* was estimated between 1.59 and 2.38 US\$ per tree. The price of *G. robusta* per tree was estimated to be between 5.56 and 7.94 US\$. The cost of cutting one tree at this stage was estimated at around 0.79 US\$. The price estimates of *C. equisetifolia* per tree by farmers varied from 0.79 to 9.52 US\$ per tree.

According to pole/timber merchants (contrary to farmers), no species is ready for sale at 48 months of age except *E. grandis*. Their price of *E. grandis* at this stage was estimated to range from 2.38-3.17 US\$. Labour cost for cutting a tree was estimated from 0.48-0.63 US\$.

Species preference by pole/timber sellers also showed that *M. lutea* was the most valuable species for Siaya. *E. grandis* was the second most preferred species followed by *G. robusta* and *C. equisetifolia*.

² Please refer to Table 4.2.1 for information on tree sizes at age 48 months for all the species.

4.2 Tree growth

This study evaluated the extent to which tree crown and root pruning influence tree survival and growth of the pruned trees. In addition, time taken in crown and root pruning, and farmers knowledge of tree species and their response to tree crown and root pruning in western Kenya have also been monitored and results are presented in the following sub-sections.

4.2.1 Siaya

4.2.1.1 Tree parameters prior to pruning, at the time of pruning and after pruning

Tree species showed significantly ($P < 0.001$) high variability in survival and in both mean height and DBH at age 48 months (just before the pruning treatments were imposed). *Markhamia lutea* scored the highest survival (100%) followed by *C. equisetifolia* and *G. robusta* in which both scored 97%. *E. grandis* recorded the least survival of 89.6%.

At this age, *E. grandis* showed the highest growth in both mean height and diameter followed by *C. equisetifolia*. *Grevillea robusta* ranked third while *M. lutea* exhibited the least growth performance (Table 4.2.1). However, there were no significant ($P > 0.05$) differences in both height and diameter growth due to the earlier P application (AFRENA, 1997).

Table 4.2.1: Tree survival and mean growth of *C. equisetifolia*, *E. grandis*, *G. robusta* and *M. lutea* at age 48 months, just before trees were pruned at Siaya, western Kenya

Species	Tree survival (%)		Mean ¹	
	Untransformed	Transformed	Height (m)	DBH (cm)
<i>C. equisetifolia</i>	97.9	81.67 ^b	12.70 ^b	13.39 ^b
<i>E. grandis</i>	89.6	71.10 ^c	14.41 ^a	17.78 ^a
<i>G. robusta</i>	97.9	81.67 ^b	8.87 ^c	10.31 ^c
<i>M. lutea</i>	100	90.00 ^a	7.37 ^d	7.56 ^d
Prob > F-ratio	-	0.0001	0.0001	0.0001
SED	-	0.71	0.13	0.22
Lsd	-	1.32	0.30	0.46

¹Values in the same column followed by different letters are significantly different ($P < 0.05$). SED is the standard error of the difference of means, Lsd = Least significant difference.

Tree branchiness, canopy spread and stem form significantly ($P < 0.001$) differed between tree species. *Markhamia lutea* scored the least branchiness while *G. robusta* scored the highest (Table 4.2.2). *Markhamia lutea* had the least canopy spread while *C. equisetifolia* showed the highest (Table 4.2.2). *Casuarina equisetifolia* scored the best stem form while *M. lutea* scored the poorest (Table 4.2.2).

Table 4.2.2: Mean scores of stem form, branchiness and canopy spread of trees at age 48 months, just before pruning at Siaya, western Kenya.

Species	Stem form	Branchiness	Canopy spread
<i>C. equisetifolia</i>	1 ^a	4 ^b	4 ^b
<i>E. grandis</i>	3 ^c	3 ^c	3 ^c
<i>G. robusta</i>	2 ^b	5 ^a	5 ^a
<i>M. lutea</i>	5 ^d	2 ^d	2 ^d
Prob > F-ratio	0.01	0.01	0.01
SED	0.11	0.09	0.09
Lsd	0.23	0.21	0.21

Values in the same column followed by different letters are significantly different ($P < 0.05$). SED is the standard error of the difference of means, Lsd = Least significant difference.

4.2.1.2 Tree pruning

4.2.1.2.1 Biomass produced from crown pruning

Species showed significant ($P < 0.001$) variability in biomass produced from prunings at Siaya site. *Eucalyptus grandis* had the highest biomass (dry weight) production at the time of first pruning followed by *C. equisetifolia* and *G. robusta* (Table 4.2.3).

Table 4.2.3: Dry biomass produced (kg/tree) from crown pruning at age 48 and 53 months (during the first and the second pruning) at Siaya, western Kenya.

Species	Age in months	
	48	53
<i>C. equisetifolia</i>	31.5 (2.2)	2.0 (0.3)
<i>E. grandis</i>	107.2 (12.6)	9.7 (0.8)
<i>G. robusta</i>	18.0 (2.3)	3.4 (0.4)
<i>M. lutea</i>	5.5 (0.5)	4.0 (0.1)
Prob > F-ratio	0.0001	0.005
Lsd ²	6.24	0.48

¹Values in the same column followed by different letters are significantly different ($P < 0.05$). ²Lsd = Least significant difference, in parentheses are standard errors of the mean of 12 observations.

4.2.1.2.2 Time taken for during the first crown and root pruning

For both crown and root pruning, time taken for tree pruning was statistically ($P < 0.001$) different between species (Table 4.2.4). Both crown and root pruning of *E. grandis* took the longest time. Crown pruning of *C. equisetifolia* used less time than *G. robusta* although, pruning of *G. robusta* root took less time than that of *C. equisetifolia*. Both crown and root pruning of *M. lutea* took the least time (Table 4.2.4).

Table 4.2.4: Time taken in tree pruning (per person per tree) at Siaya, western Kenya.

Species	Time taken (minutes/person/tree) ¹		
	Crown	Root	Total
<i>C. equisetifolia</i>	14 ^e	85 ^b	99 ^b
<i>E. grandis</i>	30 ^a	96 ^a	126 ^a
<i>G. robusta</i>	20 ^b	77 ^c	97 ^b
<i>M. lutea</i>	6 ^d	44 ^d	50 ^c
Prob > F-ratio	0.0001	0.0001	0.0001
Lsd ²	3.13	7.30	8.22

¹Values in the same column followed by different letters are significantly different ($P < 0.05$). ²Lsd = Least significant difference.

4.2.1.2.3 Amount and quality of firewood consumed from pruning of 48 months old trees

The pruned tree woody materials from all species were sun dried and were used as firewood. The result of the amount of firewood needed for one hour cooking, in a locally made closed stove, is given in Table 4.2.5. The food cooked for an hour was to feed 50-60 people.

Table 4.2.5: Firewood consumption and quality ranking of pruning materials at Siaya, western Kenya.

Species	Amount (Kg/hr)	Fire strength ¹	Level of smoke
<i>C. equisetifolia</i>	6.06 ^d	1 ^a	5 ²²
<i>E. grandis</i>	10.3 ^a	5 ^a	1 ²³
<i>G. robusta</i>	7.3 ^c	4 ^b	4 ^b
<i>M. lutea</i>	7.8 ^b	3 ^c	2 ^c
Prob > F-ratio	0.03	0.01	0.01
SED	0.28	0.11	0.12
Lsd	0.44	0.22	0.23

¹Species are ranked in ascending order for fire strength and smokiness. Values in the same column followed by different letters are significantly different ($P < 0.05$). SED is the standard error of the difference of means, Lsd = Least significant difference.

4.2.1.2.4 Tree responses to crown and root pruning

4.2.1.2.4.1 Tree survival and DBH development

During the first two assessment occasions (i.e. 10 and 24 months after pruning) tree species significantly differed ($P < 0.05$) in survival and mean DBH (Table 4.2.6). *Markhamia lutea* had highest survival and least mean DBH, while *E. grandis* had least survival and highest mean DBH. For each tree species, there were no significant ($P > 0.05$) differences between trees subjected to different pruning treatments, however, *G. robusta* seems to have higher DBH in the control (unpruned) trees (Figure 4.2.1). In addition, no significant interactions were also found between species and pruning treatments for both survival and DBH ($P > 0.05$) over time. Trends of tree mean DBH growth of various tree species and cumulative annual DBH increments over the time were significantly ($P < 0.05$) different and are shown in Figures 4.2.2

Table 4.2.6: Overall tree survival (%) and mean DBH (cm) (average of all treatments) 10 and 24 months after tree pruning at Siaya, western Kenya.

Species	Survival (%)				DBH	
	Untransformed		Transformed		10	24
	10	24	10	24		
<i>C. equisetifolia</i>	93.7	93.7	75.46 ^c	75.46 ^c	15.12 ^b	16.76 ^b
<i>E. grandis</i>	83.3	79.2	65.88 ^d	62.87 ^d	21.12 ^a	22.45 ^a
<i>G. robusta</i>	95.8	95.8	78.17 ^b	78.17 ^b	11.79 ^c	12.88 ^c
<i>M. lutea</i>	100	100	90.00 ^a	90.00 ^a	8.86 ^d	10.30 ^d
Prob > F-ratio	-	-	0.015	0.0001	0.0001	0.0001
SED	-	-	0.92	0.55	0.25	0.29
Lsd	-	-	1.87	1.14	0.56	0.61

Values in the same column followed by different letters are significantly different ($P < 0.05$). SED = Standard error of the different means. Lsd = Least significant difference.

4.2.1.2.4.2 Tree coppicing and branch re-growth

Trees of all sizes recovered from the severe crown pruning without any mortality at Siaya, although there was a large variation in branch sprouts between species (Table 4.2.7).

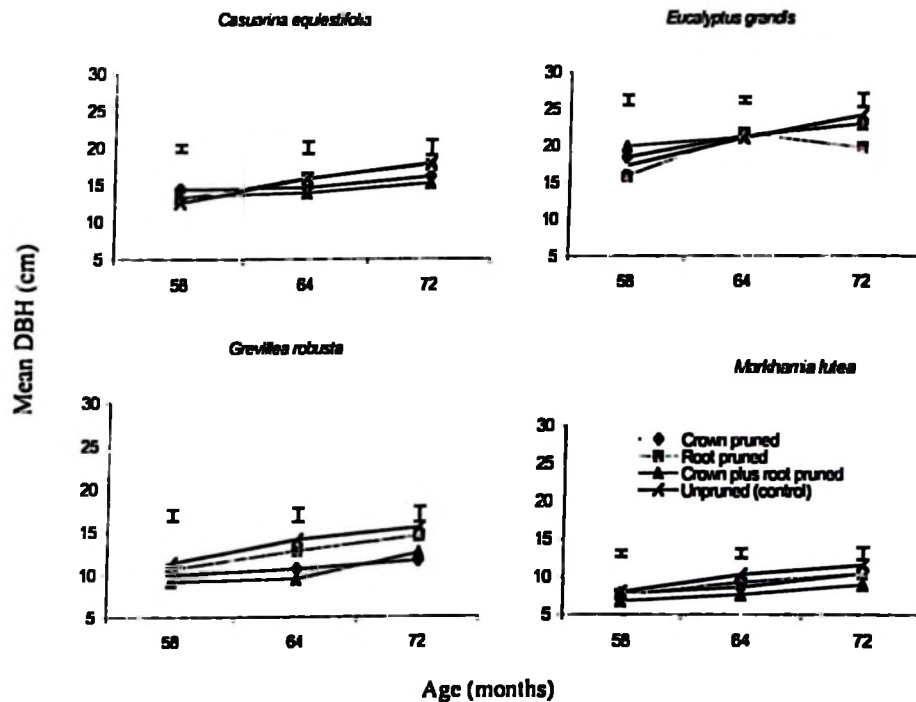

Vertical bars are standard errors of difference between means when comparing tree pruning treatment at different ages.

Figure 4.2.1: Mean DBH development over time in relation to tree species and pruning treatments at Siaya, western Kenya.

Markhamia lutea scored the highest branch sprouts up-to 3 months after pruning. It was followed by *G. robusta*, *C. equisetifolia* and *E. grandis* in that order. However, the situation changed 5 months after pruning where *E. grandis* scored the highest branch sprouts (Table 4.2.7).

Other species followed the same trend. *Markhamia lutea* became second after *E. grandis*. *Grevillea robusta* became the third in branch sprouting and *C. equisetifolia* the least. The situation remained un-changed one year after pruning (Table 4.2.7) and thereafter, except *M. lutea*.

Tree crown pruning was repeated five months after the first pruning and *E. grandis* produced the highest coppice biomass followed by *M. lutea*. *Grevillea robusta* maintained its third position while *C. equisetifolia* shifted to a fourth (least) place (Table 4.2.3).

Table 4.2.7: Mean ranking of sprouting ability of tree species after crown pruning at Siaya, western Kenya.

Species	Time after pruning (months)		
	3	5	12
<i>C. equisetifolia</i>	3 ^e	2 ^e	2 ^e
<i>E. grandis</i>	2 ^d	5 ^a	5 ^a
<i>G. robusta</i>	4 ^b	3 ^b	3 ^b
<i>M. lutea</i>	5 ^a	4 ^a	5 ^a
Prob > F-ratio	0.01	0.03	0.03
SED	0.09	0.09	0.07
Lsd	0.21	0.21	0.15

Values in the same column followed by different letters are significantly different ($P < 0.05$). SED is the standard error of the difference of means, Lsd = Least significant difference.

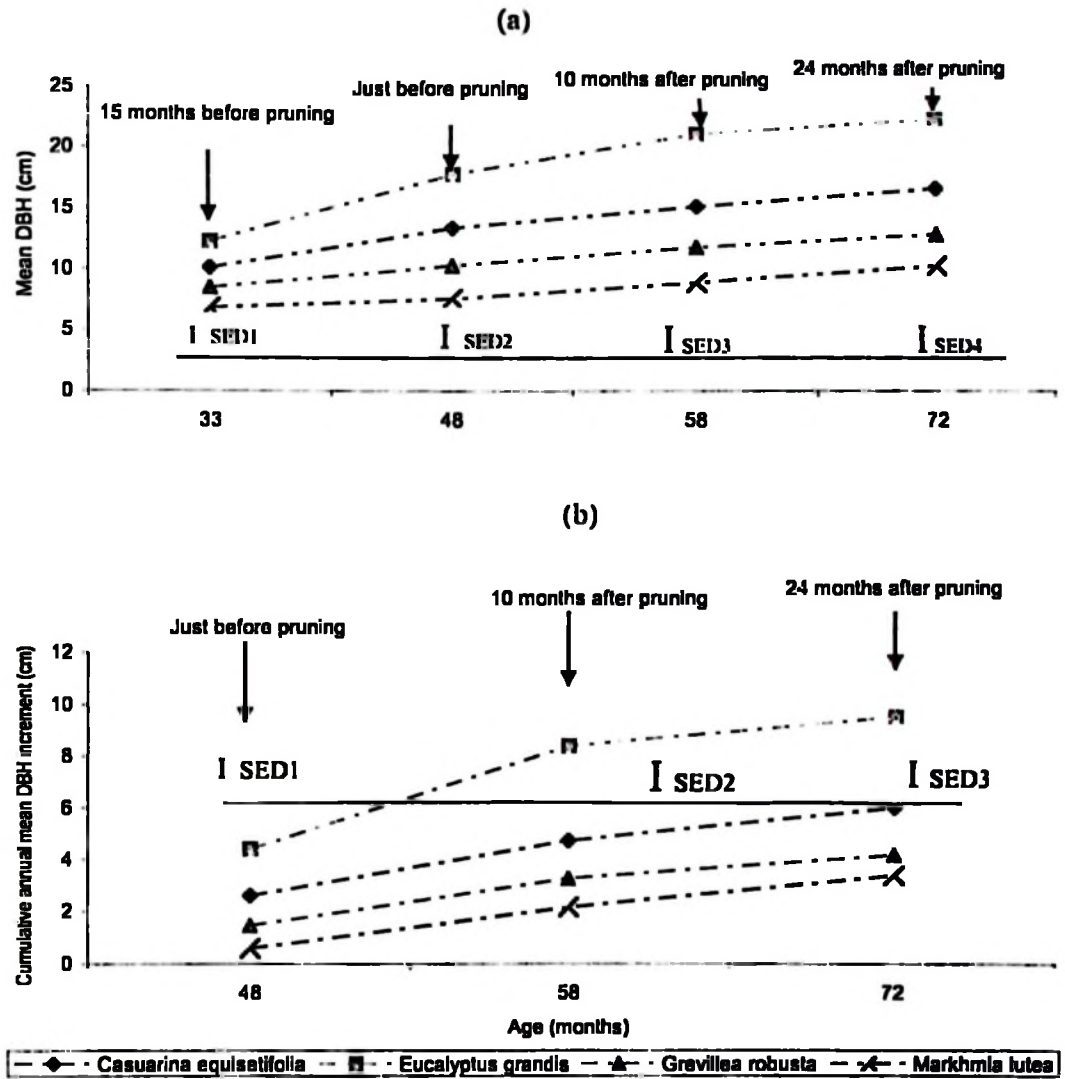

SED = Vertical bars denoted by SED1, SED2, SED3 and SED4 are standard errors of difference between means when comparing tree species at different ages.

Figure 4.2.2: Mean DBH development (a) and Cumulative mean DBH annual increments (b) of the different tree species before and after tree pruning treatments were applied at Siaya, western Kenya.

Sprouting ability of trees in terms of new branch number, length and basal diameter was assessed at 2 years after tree pruning and results are summarized in Table 4.2.8. Tree crown pruning and/or crown and root pruning did not significantly affect number, length and basal diameter of the new branch sprouts ($P > 0.05$). However, species showed significant differences in their number, length and basal diameters of branch coppices. *Eucalyptus grandis* branch sprouts were re-pruned several times since it produced branches all over its trunk. The other species were pruned only twice. Leaving *E. grandis* out of the ANOVA for coppice numbers, in testing number of new branches by species, will result in insignificant differences.

New branch length was high for *E. grandis* with 10.49 m followed by *C. equisetifolium* and *G. robusta*, each attaining coppice length of 6.9 and 6.1 m respectively. *Markhamia lutea* had the least new branch length of 5.39 m. New branch basal diameter was significantly different with *E. grandis* having 13.44 cm. *Casuarina equisetifolia* ranked next to *E. grandis* with 8.39 cm. *Markhamia lutea* and *G. robusta* had almost equal basal coppice diameter of 6.75 and 6.4 cm respectively.

4.2.1.3.4.3 Tree root re-growth

Pruning treatments (root only and a combination of crown and root pruning) did not have any effect on root re-growth of all tree species. However, species varied significantly ($P < 0.05$) in their root re-growth. *Eucalyptus grandis* trees had the least root re-growth while *G. robusta* trees had the highest (Table 4.2.9). For all the tree species, tree lateral roots within 30-cm soil depth had re-emerged at 2 years after pruning.

Table 4.2.8: Mean new branch number and coppice re-growth of different tree species, at 2 years after pruning at Siaya, western Kenya.

Measurements	<i>C. equisetifolia</i>	<i>E. grandis</i>	<i>G. robusta</i>	<i>M. lutea</i>	Prob > F-ratio	Lsd
Branch number (number)	7 (0.66) ^a	4 (0.36) ^d	6 (0.84) ^b	5 (0.35) ^c	0.0001	0.60
Branch length (m)	6.9 (0.30) ^b	10.49 (0.41) ^a	6.08 (0.37) ^c	5.39 (0.32) ^d	0.0001	0.35
Branch basal – diameter (cm)	8.39 (0.38) ^b	13.44 (0.54) ^a	6.74 (0.44) ^c	6.75 (0.37) ^c	0.0001	0.43

Values in the same rows followed by different letters are significantly different ($P < 0.05$). Numbers in parenthesis are standard errors. Lsd = Least significant difference.

Table 4.2.9: Mean root re-growth (%) potential of pruned tree roots at 2 years after pruning at Siaya, western Kenya.

Tree species	Mean root re-growth potential (%)	
	Untransformed	Transformed
<i>C. equisetifolia</i>	34.26	35.85 ^c
<i>E. grandis</i>	20.58	26.99 ^d
<i>G. robusta</i>	36.73	37.29 ^a
<i>M. lutea</i>	35.84	36.75 ^b
Prob > F-ratio	-	0.038
SED	-	4.25
Lsd	-	2.12

Values in the same column followed by different letters are significantly different ($P < 0.05$). SED is the standard error of the difference of means. Lsd = Least significant difference.

4.2.2 Nyabeda

4.2.2.1 Tree parameters prior to tree pruning

Out of 81 trees planted in the test, only one tree was found missing both during and after tree root prunings. Mean tree survival, height and DBH just before root pruning were as shown in Table 4.2.10. Trees were similar in their height and diameter at breast height and there were no significant differences between *G. robusta* trees.

4.2.2.2 Time taken for tree root pruning

Average time required for root pruning was 24 minutes per tree per person with a range of 14 to 27 minutes per tree per person.

Table 4.2.10: Tree survival (%) and growth of *G. robusta* at age 6 years, just before root pruning was imposed at Nyabeda, western Kenya.

	Survival (%)		Height (m)	DBH (cm)	Volume (m ³)
	Untras formed	Trans Formed			
Mean	98.8	83.71	13.03	13.72	0.071
Prob > F-ratio		0.999	0.562	0.471	0.787
SED		3.83	0.22	0.34	0.004

Prob > F-ratio = Probability value from ANOVA output and Fisher's F test.
SED = Standard error of the different means.

4.2.2.3 Tree survival, height, DBH and root regrowth responses to root pruning

Tree growth for Nyabeda was assessed a year after root pruning was applied. Tree survival was not affected by root pruning. Trees showed no significant differences in height and diameter growth due to root pruning. The growth of trees which were root pruned on one side was similar to that of trees which were not root pruned (i.e. controls) (Table 4.2.11).

Table 4.2.11: Mean growth parameters for *G. robusta* trees 1 year after root pruning at Nyabeda, western Kenya.

Treatments	Height (m)	DBH (cm)	Volume (m ³)
One-side pruned & the other side un-pruned	12.90	15.40	0.089
Both sides un-pruned control	13.60	15.90	0.100
Mean	13.27	15.66	0.090
Prob > F-ratio	0.052	0.899	0.874
SED	0.25	0.41	0.005

SED = Standard error of the different means,

Prob > F-ratio = Probability value from ANOVA output and Fisher's F test.

Tree root regrowth of *G. robusta* root pruned boundary trees at Nyabeda was assessed two years after root pruning was applied. The same techniques and procedures were applied as in Siaya, in assessing tree root regrowth. Results showed that there was a 7.5% root re-growth.

4.3 Soil water

Results of the influence of tree pruning on volumetric soil water content (%VSWC) at Siaya are presented in section 4.3.1 while those for Nyabeda are presented in section 4.3.2.

4.3.1 Siaya

4.3.1.1 Soil water content in the upper 30 cm of the soil profile as measured by

Thetaprobe during three maize cropping seasons at Siaya, western Kenya

Percent volumetric soil water content (%VSWC) of the top 30 cm soil layer was monitored during the first 3 cropping seasons of maize planting after tree pruning using a Thetaprobe. The ANOVA showed that both species and tree pruning treatments had significantly ($P < 0.001$) different effects on %VSWC. Increasing distance from the tree line significantly ($P < 0.001$) affected %VSWC when measurements were made during the wetter months but not when measurements were made during drier months (Table 4.3.1).

The effect of the interactions of species and tree pruning treatments on %VSWC was significant during all cropping seasons except for the third cropping season of 2000 short rain (Table 4.3.1). All other interactions of species, tree pruning and increasing distance had no significant effect on soil moisture (Table 4.3.1).

For all tree species, both crown and root pruning treatments conserved soil water as compared to the un-pruned (control) treatment during the first 3 cropping seasons (Tables 4.3.2 and 4.3.3). A combination of crown plus root pruning was more effective in conserving soil moisture under *E. grandis* and *M. lutea* but not under *C. equisetifolia* where crown pruning was more effective in conserving soil water during the first cropping season i.e. long rain in 1999. For *G. robusta*, both crown

only and root only prunings were more effective than a combination of crown plus root pruning in improving soil water status. Root pruning of *C. equisetifolia*, *E. grandis* and *M. lutea* was less effective in conserving soil moisture as compared to the crown, and crown plus root pruning treatments but were all better when compared with the unpruned (control) tree plots.

Table 4.3.1: Probability values from ANOVA examining the effects of species, tree pruning and increasing distance, and their interaction on %VSWC of the top 30 cm of the soil profile during the 3 maize growing seasons at Siaya, western Kenya.

Source of variation	Maize season – 1 long rain 1999		Maize season – 2 Short rain 1999		Maize season – 3 long rain 2000	
	April (wet)	July (dry)	October (wet)	January (dry)	April (wet)	July (dry)
Species (S)	0.003**	0.0001**	0.0001**	0.0001**	0.0001**	0.000**
Pruning (P)	0.0001**	0.0001**	0.0001**	0.0001**	0.0001**	0.000**
Distance (D)	0.0001**	0.076	0.0001**	0.115	0.0001**	0.450
S x P	0.026*	0.0001**	0.0001**	0.001**	0.001**	0.087
S x D	0.108	0.514	0.063	0.283	0.075	0.233
P x D	0.873	0.498	0.064	0.082	0.584	0.218
S x P x D	0.256	0.77	0.674	0.843	0.61	0.335

* = Significant at $p < 0.05$ and ** = Significant at $p < 0.001$.

During the second season of the short rain in 1999, root pruned *E. grandis* and *G. robusta* trees resulted in highest soil moisture content. The root pruned plots of *M. lutea* showed similar soil moisture content to unpruned (control) tree plots, while root-pruned tree plots of *C. equisetifolia* had the least %VSWC (Tables 4.3.4 and 4.3.5). No significant increase in soil moisture was noted under the maize only (sole maize) control plot compared to the moisture under the pruned trees during the first two cropping seasons (Tables 4.3.2, 4.3.3, 4.3.4 and 4.3.5).

Table 4.3.2: Mean volumetric soil water content (%)¹ of the top 0-30 cm soil layer under different tree species, pruning treatments and all distances at Siaya, western Kenya.

April-May 1999				
	<i>C. equisetifolia</i>	<i>E. grandis</i>	<i>G. robusta</i>	<i>M. lutea</i>
Crown pruning	24.28 ^a	21.25 ^b	22.30 ^b	20.44 ^c
Root pruning	17.19 ^c	19.58 ^c	22.83 ^a	21.08 ^b
Crown + Root Pruning	21.37 ^b	23.95 ^a	18.90 ^c	22.48 ^a
Un-pruned control	16.48 ^c	14.97 ^d	17.50 ^d	18.60 ^d
Prob > F-ratio	0.001	0.000	0.008	0.000
SED	0.47	0.42	0.43	0.38
Lsd	0.85	0.73	0.84	0.75
Sole maize = 23.79	SE = 0.42			

June-July 1999				
	<i>C. equisetifolia</i>	<i>E. grandis</i>	<i>G. robusta</i>	<i>M. lutea</i>
Crown pruning	14.12 ^a	14.57 ^b	15.46 ^a	14.20 ^b
Root pruning	12.24 ^b	13.07 ^c	13.43 ^b	13.10 ^c
Crown + Root Pruning	12.70 ^b	16.48 ^a	13.62 ^b	15.12 ^a
Un-pruned control	11.25 ^c	9.12 ^d	11.63 ^c	11.64 ^d
Prob > F-ratio	0.000	0.000	0.000	0.001
SED	0.29	0.33	0.32	0.29
Lsd	0.57	0.55	0.62	0.55
Sole maize = 15.12	SE = 0.32			

For each study period, mean values in same column or the same row followed by different letters are significantly different ($p < 0.05$), Lsd = least significant difference, SED = standard error of the differences of means, SE = Standard error of the mean, ¹Mean of 8 measurements, 1-6 months after pruning, 1st cropping season long-rain 1999.

During the third season of April-May i.e. long rain 2000, soil moisture within the top 0-30 cm soil profile under all pruned tree plots was higher than the unpruned (control) tree plots (Tables 4.3.6 and 4.3.7).

During the third season i.e. June-July 2000, *C. equisetifolia* had lost all the positive gain in soil moisture, due to tree pruning since no significant differences were noted between pruned and the unpruned (control) tree plots. *Eucalyptus grandis* and *G. robusta* tree pruned plots only differed from corresponding unpruned (control) plots, while %VSWC under *M. lutea* crown and crown plus root pruned plots, and root pruned and unpruned (control) tree plots was the same (Table 4.3.6).

Table 4.3.3: Half matrix of pair wise comparisons of tree species and pruning treatments for mean volumetric soil water content (%) pooled for all distances and depths for 1st season long rain 1999 at Siaya, western Kenya.

	Sole- maize	Unpruned (control)	Root pruned	Crown Pruned
<i>C. equisetifolia</i>				
Crown + root pruned	1*	2*	3*	4*
Crown pruned	5	6*	7*	
Root pruned	8*	9		
Unpruned (control)	10*			
<i>E. grandis</i>				
Crown + root pruned	1*	2*	3	4*
Crown pruned	5	6*	7*	
Root pruned	8*	9*		
Unpruned (control)	10*			
<i>G. robusta</i>				
Crown + root pruned	1*	2*	3*	4*
Crown pruned	5*	6*	7*	
Root pruned	8*	9*		
Unpruned (control)	10*			
<i>M. lutea</i>				
Crown + root pruned	1*	2*	3*	4*
Crown pruned	5*	6*	7*	
Root pruned	8*	9*		
Unpruned (control)	10*			

* = Significant at $p < 0.05$.

Table 4.3.4: Mean volumetric soil water content (%)¹ of the top 0-30 cm soil layer under different tree species, pruning treatments and all distances at Siaya, western Kenya.

October – November 1999				
	<i>C.</i>	<i>E.</i>	<i>G.</i>	<i>M.</i>
	<i>equisetifolia</i>	<i>grandis</i>	<i>Robusta</i>	<i>lutea</i>
Crown pruning	26.76 ^a	20.87 ^c	23.89 ^b	23.11 ^c
Root pruning	19.20 ^d	27.24 ^a	25.67 ^a	25.69 ^a
Crown + Root Pruning	24.55 ^b	22.06 ^b	21.78 ^c	24.04 ^b
Un-pruned control	20.89 ^c	22.14 ^b	23.25 ^b	25.28 ^a
Prob > F-ratio	0.000	0.000	0.000	0.000
SED	0.38	0.39	0.41	0.40
Lsd	0.68	0.74	0.80	0.80
Sole maize = 22.57	SE = 0.37			

December 1999 – January 2000				
	<i>C.</i>	<i>E.</i>	<i>G.</i>	<i>M.</i>
	<i>equisetifolia</i>	<i>grandis</i>	<i>Robusta</i>	<i>lutea</i>
Crown pruning	10.12 ^b	12.39 ^{ab}	10.29 ^b	11.81 ^a
Root pruning	7.46 ^d	12.93 ^a	14.45 ^a	11.29 ^a
Crown + Root Pruning	11.97 ^a	12.47 ^b	10.35 ^b	11.55 ^a
Un-pruned control	8.44 ^c	11.45 ^c	9.05 ^c	9.46 ^b
Prob > F-ratio	0.001	0.008	0.001	0.005
SED	0.34	0.33	0.36	0.33
Lsd	0.65	0.66	0.69	0.66
Sole maize = 10.74	SE = 0.37			

For each study period, mean values in same column or the same row followed by different letters are significantly different ($p < 0.05$), Lsd = least significant difference, SED = standard error of the differences of means. SE = Standard error of the mean, ¹Mean of 8 measurements, 7-12 months after pruning, 2nd cropping season short-rain 1999.

4.3.1.2 Effect of increasing distance from tree line on soil water content with the upper 30 cm soil depth as measured by Thetaprobe during three maize cropping seasons at Siaya

Although %VSWC increased significantly ($P < 0.001$) with increasing distance from the tree line in all the maize cropping seasons during the wetter months, none of its interactions with species and pruning treatments had significant effect (Table 4.3.1).

However, evaluation of the effect of pruning on variation of soil water with increasing distance from tree line, showed that the unpruned (control) plots under each tree species with distance from tree line had significantly lower %VSWC during the wetter months of the first season in April – May 1999 (Figure 4.3.1).

Table 4.3.5: Half matrix of pair wise comparisons of tree species and pruning treatments for mean volumetric soil water content (%) pooled for all distances and depths for 2nd season short rain 1999 at Siaya, western Kenya.

	Sole- maize	Unpruned (control)	Root pruned	Crown Pruned
<i>C. equisetifolia</i>				
Crown + root pruned	1*	2*	3*	4*
Crown pruned	5	6*	7*	
Root pruned	8*	9		
Unpruned (control)	10*			
<i>E. grandis</i>				
Crown + root pruned	1*	2*	3*	4*
Crown pruned	5	6*	7*	
Root pruned	8*	9*		
Unpruned (control)	10			
<i>G. robusta</i>				
Crown + root pruned	1*	2*	3*	4*
Crown pruned	5*	6	7*	
Root pruned	8*	9*		
Unpruned (control)	10*			
<i>M. lutea</i>				
Crown + root pruned	1*	2*	3*	4*
Crown pruned	5*	6*	7*	
Root pruned	8*	9		
Unpruned (control)	10*			

* = Significant at $p < 0.05$.

Table 4.3.6: Overall mean volumetric soil water content (%)¹ in the top 0-30 cm soil layer under different tree species² at Siaya, western Kenya.

April-May 2000				
	<i>C. equisetifolia</i>	<i>E. grandis</i>	<i>G. Robusta</i>	<i>M. lutea</i>
Crown pruning	9.61 ^a	9.20 ^b	10.45 ^a	11.44 ^a
Root pruning	7.70 ^c	10.02 ^a	8.78 ^c	9.60 ^b
Crown + Root Pruning	10.03 ^a	9.14 ^b	9.88 ^b	10.67 ^b
Un-pruned control	8.74 ^b	8.63 ^c	8.27 ^d	9.07 ^c
Prob > F-ratio	0.000	0.001	0.000	0.009
SED	0.22	0.21	0.22	0.24
Lsd	0.44	0.41	0.44	0.47
Sole maize = 11.68	SE = 0.23			
June-July 2000				
Crown pruning	10.97 ^a	10.83 ^{ab}	11.72 ^a	12.14 ^a
Root pruning	10.59 ^b	10.55 ^b	11.32 ^b	10.68 ^c
Crown + Root Pruning	10.98 ^a	11.10 ^a	11.47 ^{ab}	11.87 ^b
Un-pruned control	10.38 ^b	9.63 ^c	9.85 ^c	10.90 ^c
Prob > F-ratio	0.047	0.021	0.042	0.011
SED	0.15	0.16	0.15	0.16
Lsd	0.29	0.31	0.28	0.31
Sole maize = 13.06	SE = 0.22			

For each study period, mean values in same column or the same row followed by different letters are significantly different ($p < 0.05$), Lsd = least significant difference, SED = standard error of the differences of means. SE = Standard error of the mean, ¹Mmean of 8 measurements, 13-18 months after pruning, 3rd cropping season long-rain 2000. ²Pooled for all distances from the tree line.

Crown and crown plus root pruning of *C. equisetifolia* improved soil water content by 20-25% as compared to the unpruned (control) plots, when soil water content was compared at 1 and 3 m distance during the first cropping season i.e. April-May long rain 1999 (Figure 4.3.1). The un-pruned (control) and root pruned plots of *C. equisetifolia* showed no significant differences in %VSWC at both 1 and 3-m distances from tree lines.

A significant increase in %VSWC with increasing distance from the tree line was noted under *E. grandis* during the first season long rain 1999 where crown, root and crown and root pruning of *E. grandis* trees resulted in an increase in %VSWC of 25-50 (Figure 4.3.1) as compared to the unpruned (control) tree plots.

Table 4.3.7: Half matrix of pair wise comparisons of tree species and pruning treatments for mean volumetric soil water content (%) pooled for all distances and depths for 3rd season long rain 2000 at Siaya, western Kenya.

	Sole- maize	Unpruned (control)	Root pruned	Crown Pruned
<i>C. equisetifolia</i>				
Crown + root pruned	1*	2*	3*	4*
Crown pruned	5*	6*	7*	
Root pruned	8*	9*		
Unpruned (control)	10*			
<i>E. grandis</i>				
Crown + root pruned	1*	2*	3*	4*
Crown pruned	5	6*	7*	
Root pruned	8*	9*		
Unpruned (control)	10*			
<i>G. robusta</i>				
Crown + root pruned	1*	2*	3*	4*
Crown pruned	5*	6	7*	
Root pruned	8*	9*		
Unpruned (control)	10*			
<i>M. lutea</i>				
Crown + root pruned	1	2*	3	4*
Crown pruned	5*	6*	7*	
Root pruned	8*	9*		
Unpruned (control)	10*			

* = Significant at $p < 0.05$.

For *G. robusta* and *M. lutea*, %VSWC also increased with increasing distance, during the first maize cropping season i.e. long rain 1999, but no significant differences were noted between the treatments during all the three cropping seasons.

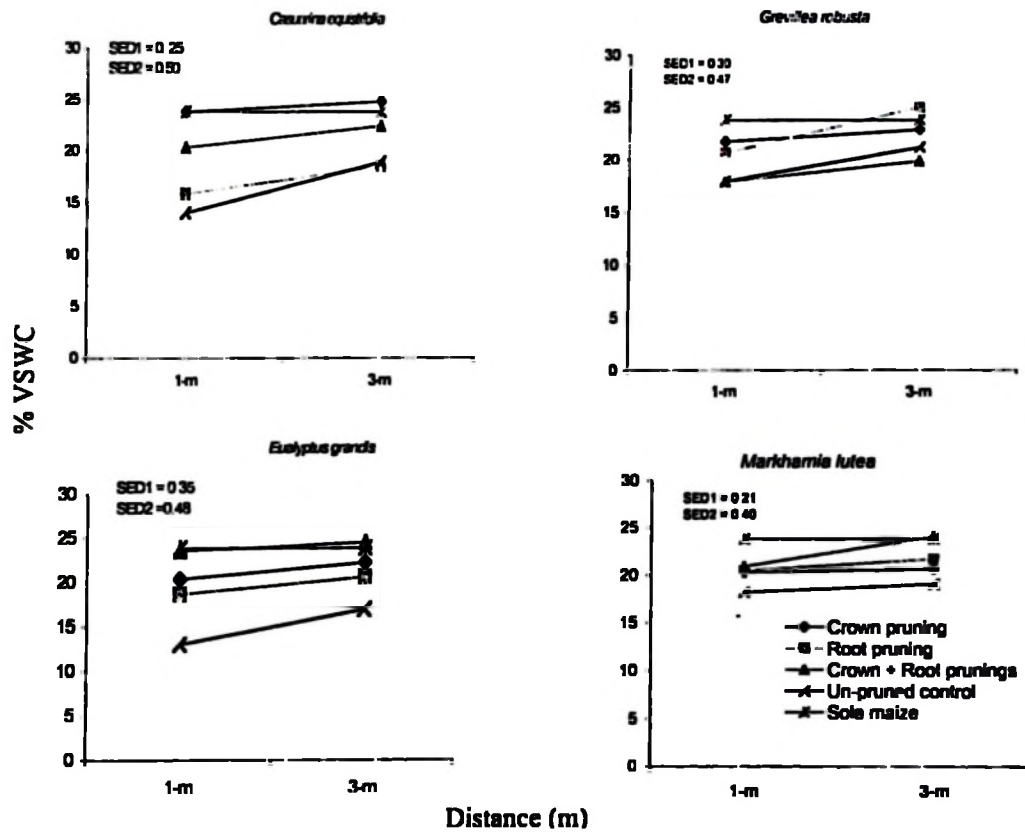

SED1 = Standard error of the means between distances in a treatment
 SED2 = Standard error of the means between treatments for a given distance.

Figure 4.3.1: Effect of tree pruning and increasing distance from tree lines on mean volumetric soil water content (%) during the 1st season long-rain, April-May 1999 at Siaya, western Kenya.

During the second maize cropping seasons of short-rain 1999, there was significant increase in %VSWC under crown and crown plus root pruned *C. equisetifolia* plots as distance increased from tree lines (Figure 4.3.2). These plots had the same or more %VSWC than the sole maize while the unpruned (control) and root pruned tree plots exhibited similar trends but resulted in less water content than the crown and crown plus root pruned tree plots.

During the second maize growing season of short-rain 1999, %VSWC under *E. grandis* root pruned plot was higher than the sole maize while the other treatments were statistically the same with the sole maize. There was no increase in %VSWC with increasing distance during the second season.

During the third season i.e. short-rain 2000, %VSWC increased with distance in all the pruned tree plots but no significant differences were noted among the pruning treatments under *C. equisetifolia* (Figure 4.3.3). No significant differences were noted between pruning treatments under Eucalypts, although the soil under root pruned plots had more water in the first three rows.

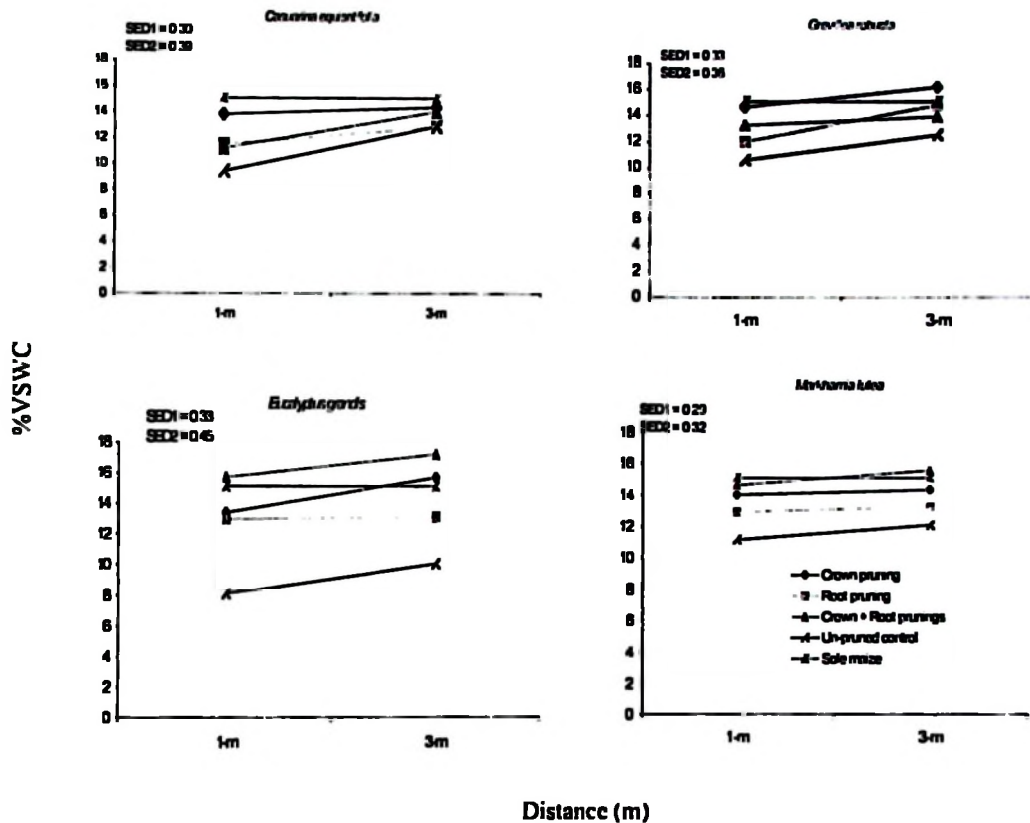

SED1 and SED2 as defined in Figure 4.3.1.

Figure 4.3.2: Effect of tree pruning and increasing distance from tree lines on mean volumetric soil water content (%) during the 2nd season short-rain, October-November 1999 at Siaya, western Kenya.

Generally, crown and crown plus root pruning of all tree species conserved more soil water than other treatments. For all species at all distance, unpruned (control) tree plots conserved least soil water, while sole maize plot had highest %VSWC. These effects were more pronounced in *C. equisetifolia* and *E. grandis* as compared to the other species. For all species and all assessments, except *M. lutea*, %VSWC increased with increase in distance from the tree line.

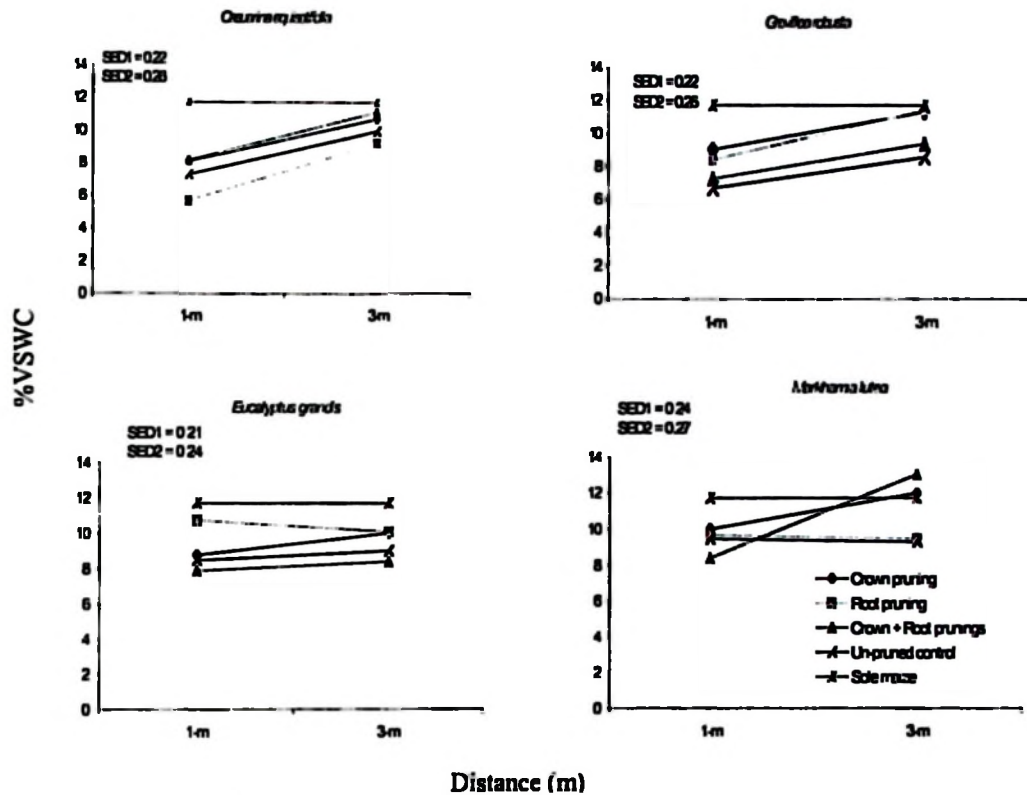

SED1 and SED2 as defined in Figure 4.3.1.

Figure 4.3.3: Effect of tree pruning and increasing distance from tree lines on mean volumetric soil water content (%) during the 3rd season long-rain, April-May 2000 at Siaya, western Kenya.

4.3.1.3 Soil water content pooled for all distances

When %VSWC for all soil distances were pooled, the effect of tree species and pruning treatments on %VSWC under each species was significantly ($P < 0.05$) different during long and short rains (Tables 4.3.9 and 4.3.10 and 4.3.11). In April-May there was more %VSWC under crown plus root-pruned *C. equisetifolia* and *E. grandis* trees.

During the long rain of 2000 i.e. June-July, pruning treatments of *M. lutea* did not show any significant variation while pruning treatments of *E. grandis*, *C. equisetifolia* and *G. robusta* significantly differed in their effect on %VSWC (Table 4.3.6). In the short rain of September-October 2000, %VSWC was significantly less under root pruned *E. grandis* tree plots compared to the unpruned (control) tree plots and other pruning treatments, while %VSWC under all other species and pruning treatments did not significantly differ from their unpruned (control) tree plots (Table 4.3.10).

On the other hand, during the November – December short rain 2000, all tree species and pruning treatments significantly ($P < 0.05$) affected %VSWC. For *C. equisetifolia*, the soil under crown plus root pruned and unpruned (control) trees had more %VSWC while soil under *M. lutea* crown and root only pruned exhibited more %VSWC. There was more %VSWC under crown plus root and root only pruned *E. grandis* trees while *G. robusta* pruned plots had more %VSWC compared to the unpruned (control) plots (Table 4.3.9).

4.3.1.4 Effect of soil depth on soil water content in relation to tree species, pruning, treatments and distance from tree line as measured by Neutron probe during the third and fourth cropping seasons i.e. long and short rains of 2000

Soil moisture measurements by neutron probe were started during the third cropping season after tree pruning (long rains of 2000) and continued until the end of the short rains 2000. Moisture readings by neutron probe were taken between 20 cm soil depth

and below. The effects of species, pruning treatments and soil depths on %VSWC were statistically significant ($P > 0.001$) on all assessment occasions. However, the effects of all interactions (species, pruning, distance and depths) on %VSWC were not significantly ($P > 0.05$) different (Table 4.3.12).

During maize growing seasons in April-May (long rains) and September-October (short rains) 2000, water was more significantly depleted from 0-20 cm soil depth as compared to the soil below this depth under all the tree species and all pruning treatments (Table 4.3.12).

When soil water data was pooled for all tree pruning treatments and distances, %VSWC increased with an increase in soil depth for all the four tree species (Table 4.3.12). As the season progressed in the long rains of 2000, depletion of soil water extended further down to 20-40 cm under all tree species. The sole maize plot had the highest soil moisture content at all soil depths (Table 4.3.12).

Soil water was depleted from the top 20-60 cm depth under all tree species but with significant variability between the different tree pruning treatments. Soil water increased with an increase in soil depths (Table 4.3.10).

Table 4.3.8: Probability values from ANOVA examining the effect of species, pruning treatments, soil depth of and distance from tree lines and their interactions on %VSWC during long and short rains 2000, at Siaya, western Kenya.

Source of variation	Maize season – 3 long rain 2000		Maize season – 4 Short rain 2000	
	April (wet)	July (dry)	October (wet)	January (dry)
Species (S)	0.0001**	0.0001**	0.0001**	0.028*
Pruning (P)	0.0001**	0.0001**	0.0001**	0.0001**
Depths (DE)	0.0001**	0.0001**	0.0001**	0.0001**
Distance (D)	0.550	0.937	0.783	0.608
S x P	0.0001**	0.005*	0.047*	0.000**
S x DE	0.774	0.842	0.522	0.999
S x D	0.387	0.485	0.06	0.500
P x DE	0.980	0.998	0.987	0.507
P x D	0.256	0.938	0.573	0.06
S x P x DE	0.747	0.712	0.739	0.532
S x P x D	0.159	0.194	0.303	0.243
S x P x DE x D	0.354	0.432	0.625	0.673

* = Significant at $p < 0.05$ and ** = Significant at $p < 0.001$.

The soil within 20-100 cm depth under *C. equisetifolia* was drier in all the assessment occasions. The soil depths (20-100 cm) under *M. lutea* had the second highest water content, after the sole maize plot during all measurement occasions. On the other hand, soil under *E. grandis* and *G. robusta* resulted in similar soil water content except for the driest and the wettest periods (long rain April-May & short rain September-November).

During the driest period (long rain June-July 2000 & short rain December-January 2000), soils (20-100 cm depths) under *E. grandis* contained more soil water than those under *G. robusta* and was vice-versa for assessments made during the wettest period (Table 4.3.12).

Table 4.3.9: Mean volumetric soil water content (%)¹ under species and pruning treatments for all soil depths and distances at Siaya, western Kenya.

April-May long rain 2000				
	<i>C. equisetifolia</i>	<i>E. grandis</i>	<i>G. robusta</i>	<i>M. lutea</i>
Crown pruning	30.52 ^p	31.14 ^e	31.46 ^b	33.10 ^a
Root pruning	30.36 ^h	31.72 ^b	31.32 ^b	32.03 ^a
Crown + Root Pruning	32.72 ^a	32.25 ^a	32.01 ^a	31.96 ^a
Un-pruned control	30.62 ^h	30.23 ^d	32.00 ^a	31.23 ^b
Prob > F-ratio	0.000	0.000	0.000	0.000
SED	0.21	0.17	0.18	0.17
Lsd	0.40	0.35	0.36	0.33
Sole maize = 33.93 SE = 0.15				
June-July short rain 2000				
	<i>C. equisetifolia</i>	<i>E. grandis</i>	<i>G. robusta</i>	<i>M. lutea</i>
Crown pruning	29.35 ^c	30.04 ^b	30.10 ^a	31.48 ^a
Root pruning	29.91 ^b	30.37 ^b	30.41 ^a	31.06 ^a
Crown + Root Pruning	30.70 ^a	30.93 ^a	30.47 ^a	31.26 ^a
Un-pruned control	30.20 ^{ab}	30.60 ^{ab}	29.07 ^b	30.57 ^a
Prob > F-ratio	0.007	0.013	0.047	0.532
SED	0.20	0.19	0.21	0.17
Lsd	0.39	0.38	0.42	0.34
Sole maize = 31.67 SE = 0.18				

For each study period, mean values in same column or the same row followed by different letters are significantly different ($p < 0.05$), Lsd = least significant difference, SED = standard error of the differences of means. SE = Standard error of the mean, ¹ Mean of 8 measurements, 18-24 months after pruning, 3rd cropping season long rain 2000.

During the third maize growing short rain 2000, water depletion occurred within 0-60 cm soil depth and interestingly %VSWC under *C. equisetifolia*, *E. grandis* and *G. robusta* increased significantly from 60-80 cm soil depth and then dropped gradually within 80-100 cm soil depth. The %VSWC at 80-100 cm soil depth was statistically similar to that of 20-40 cm soil depth but significantly less than that of 60-80 cm soil depth. However, an exceptional case was noted for *M. lutea* plots where water depletion mainly occurred within the upper 0-40 cm soil depth and followed a similar trend to that of soils under sole maize plots (Table 4.3.13). The soil depths (20-100 cm) under *C. equisetifolia* were drier in all assessment occasions.

Table 4.3.10: Mean volumetric soil water content (%)¹ for all pruning treatments and all distances under tree species at Siaya, western Kenya.

September-October short rain 2000				
	<i>C. equisetifolia</i>	<i>E. grandis</i>	<i>G. robusta</i>	<i>M. lutea</i>
Crown pruning	28.21 ^c	28.93 ^b	28.92 ^{ab}	29.65 ^a
Root pruning	28.46 ^b	28.96 ^b	28.75 ^b	29.43 ^{ab}
Crown + Root Pruning	28.76 ^a	29.61 ^a	29.11 ^a	29.35 ^{bc}
Un-pruned control	28.41 ^{bc}	28.62 ^c	27.91 ^c	28.52 ^c
Prob > F-ratio	0.074	0.053	0.055	0.062
SED	0.12	0.11	0.14	0.12
Lsd	0.23	0.21	0.26	0.22
Sole maize =	29.63	SE = 0.11		

November-December short rain 2000				
	<i>C. equisetifolia</i>	<i>E. grandis</i>	<i>G. robusta</i>	<i>M. lutea</i>
Crown pruning	29.29 ^b	30.52 ^b	30.25 ^b	31.03 ^a
Root pruning	29.56 ^b	30.90 ^a	30.43 ^b	30.89 ^a
Crown + Root Pruning	31.22 ^a	30.93 ^a	30.86 ^a	30.33 ^b
Un-pruned control	30.00 ^a	29.66 ^c	28.98 ^c	29.71 ^c
Prob > F-ratio	0.034	0.023	0.040	0.031
SED	0.18	0.15	0.17	0.18
Lsd	0.34	0.29	0.33	0.35
Sole maize =	32.67	SE = 0.19		

For each study period, mean values in same column or the same row followed by different letters are significantly different ($p < 0.05$). Lsd=least significant difference, SED=standard error of the differences of means. SE = Standard error of the mean, ¹ Mean of 8 measurements, 25-30 months after pruning, 4th cropping season short rain 2000.

For each tree species, water depletion of the unpruned (control) plots occurred within the top 20-80 cm soil depth. For all soil depths, the sole maize plot had the highest water content on all the assessment occasions. Water content between 20-60 cm soil depths was high for crown plus root pruned trees followed by crown-pruned trees except during the driest period (Figures, 4.3.4, 4.3.5 & 4.3.6).

Table 4.3.11: Half matrix of pair wise comparisons of tree species and pruning treatments for mean volumetric soil water content (%) pooled for all distances and depths for 4th season short rain 2000 at Siaya, western Kenya.

	Sole- maize	Unpruned (control)	Root pruned	Crown Pruned
<i>C. equisetifolia</i>				
Crown + root pruned	1*	2	3*	4*
Crown pruned	5*	6*	7	
Root pruned	8*	9*		
Unpruned (control)	10*			
<i>E. grandis</i>				
Crown + root pruned	1*	2*	3	4*
Crown pruned	5*	6*	7*	
Root pruned	8*	9*		
Unpruned (control)	10*			
<i>G. robusta</i>				
Crown + root pruned	1*	2*	3*	4*
Crown pruned	5*	6*	7	
Root pruned	8*	9*		
Unpruned (control)	10*			
<i>M. lutea</i>				
Crown + root pruned	1	2*	3	4*
Crown pruned	5*	6*	7	
Root pruned	8*	9*		
Unpruned (control)	10*			

* = Significant at $p < 0.05$.

In general, %VSWC increased with soil depth with greater increase during the long rains of June-July 2000. The proportion of water increase with soil depth was greater under trees as compared to sole maize crop.

Table 4.3.12: Effect of soil depth on mean volumetric soil water content (%)¹ for all pruning treatments and all distances under tree species at Siaya, western Kenya.

April- May 2000					
Soil depth (cm)	<i>C. equisetifolia</i>	<i>E. grandis</i>	<i>G. robusta</i>	<i>M. lutea</i>	Sole maize
0-20	27.78 ^f	27.95 ^f	27.61 ^f	27.76 ^e	31.29 ^e
20-40	29.67 ^e	31.04 ^e	31.31 ^e	32.06 ^d	34.97 ^d
40-60	30.51 ^d	31.52 ^d	31.21 ^e	32.99 ^c	34.29 ^c
60-80	30.94 ^d	31.43 ^{de}	31.35 ^{de}	31.74 ^{hd}	34.15 ^c
80-100	30.96 ^d	31.27 ^{de}	31.71 ^d	31.89 ^{bd}	33.58 ^c
100-120	31.59 ^c	31.96 ^c	32.13 ^d	32.23 ^d	33.68 ^c
120-140	32.32 ^b	32.77 ^b	32.70 ^c	33.09 ^b	34.15 ^b
140-160	32.71 ^b	33.02 ^{ah}	33.45 ^a	33.42 ^{ab}	34.54 ^{ab}
160-180	33.01 ^a	33.31 ^a	33.80 ^a	33.54 ^a	34.68 ^a
Prob>F-ratio	0.014	0.023	0.046	0.012	0.035
Lsd	0.55	0.43	0.41	0.39	0.40
Long rain June – July 2000					
0-20	25.84 ^f	25.37 ^e	24.64 ^f	26.32 ^f	27.23 ^f
20-40	28.17 ^e	29.42 ^d	28.55 ^e	30.30 ^e	30.79 ^e
40-60	29.70 ^d	30.12 ^c	29.77 ^d	31.48 ^d	30.64 ^e
60-80	30.06 ^{cd}	30.35 ^c	30.10 ^{cd}	31.30 ^{cd}	31.10 ^d
80-100	30.17 ^c	30.32 ^c	29.93 ^c	31.03 ^c	31.80 ^c
100-120	30.26 ^{bc}	31.27 ^b	30.53 ^c	31.22 ^{cd}	32.47 ^b
120-140	31.66 ^b	32.25 ^a	31.74 ^b	32.34 ^b	33.38 ^a
140-160	32.17 ^{ab}	32.45 ^a	32.24 ^a	32.77 ^a	33.63 ^a
160-180	32.23 ^a	32.50 ^a	32.62 ^a	33.02 ^a	33.40 ^a
Prob>F-ratio	0.003	0.009	0.001	0.037	0.041
Lsd	0.45	0.39	0.43	0.34	0.36

For each study period, mean values in same column or the same row followed by different letters are significantly different ($p < 0.05$). Lsd = least significant difference. ¹Mean of 8 measurements, 18-24 months after pruning, 3rd cropping season long rain 2000.

Table 4.3.13: Effect of soil depth on mean volumetric soil water content (%)¹ for all pruning treatments and all distances under tree species at Siaya, western Kenya.

September - October 2000					
Soil depth (cm)	<i>C. equisetifolia</i>	<i>E. grandis</i>	<i>G. robusta</i>	<i>M. lutea</i>	Sole Maize
0-20	25.97 ^f	26.45 ^f	25.29 ^f	27.22 ^d	27.77 ^d
20-40	27.54 ^e	28.73 ^d	28.42 ^e	29.17 ^e	29.71 ^c
40-60	28.36 ^d	29.24 ^e	28.63 ^e	29.00 ^e	28.88 ^d
60-80	28.60 ^{cd}	28.76 ^d	28.66 ^e	29.01 ^e	28.73 ^d
80-100	28.55 ^{cd}	28.90 ^d	28.54 ^{de}	29.14 ^e	29.58 ^c
100-120	28.79 ^c	29.45 ^e	28.92 ^e	29.30 ^e	29.75 ^c
120-140	29.23 ^b	29.74 ^{bc}	29.38 ^b	29.91 ^b	30.53 ^b
140-160	29.58 ^a	29.89 ^{ab}	28.87 ^{cd}	30.04 ^a	30.79 ^{ab}
160-180	29.76 ^a	30.10 ^a	30.35 ^a	30.36 ^a	30.97 ^a
Prob>F-ratio	0.019	0.031	0.022	0.043	0.044
Lsd	0.29	0.26	0.33	0.32	0.26
November – January 2000					
0-20	27.24 ^d	27.34 ^d	26.42 ^f	27.25 ^e	29.50 ^d
20-40	29.42 ^c	30.35 ^c	29.80 ^e	30.37 ^b	33.05 ^b
40-60	30.14 ^{bc}	30.91 ^{bc}	30.49 ^{cd}	30.82 ^b	32.57 ^c
60-80	30.23 ^{bc}	30.56 ^c	30.19 ^{cd}	30.80 ^b	33.70 ^a
80-100	29.49 ^b	30.31 ^c	29.89 ^d	30.56 ^b	33.31 ^{ab}
100-120	30.40 ^b	31.13 ^b	30.33 ^{cd}	30.54 ^b	33.32 ^{ab}
120-140	30.94 ^{ah}	31.08 ^b	30.91 ^b	31.26 ^a	33.27 ^{ab}
140-160	31.00 ^a	31.24 ^{ab}	31.28 ^a	31.14 ^a	32.96 ^{bc}
160-180	31.24 ^a	31.60 ^a	31.90 ^a	31.66 ^a	32.36 ^c
Prob>F-ratio	0.031	0.042	0.044	0.045	0.050
Lsd	0.48	0.38	0.43	0.48	0.52

For each study period, mean values in same column or the same row followed by different letters are significantly different ($p < 0.05$). Mean of 8 measurements, 25-30 months after pruning, 4th cropping season short rain 2000.

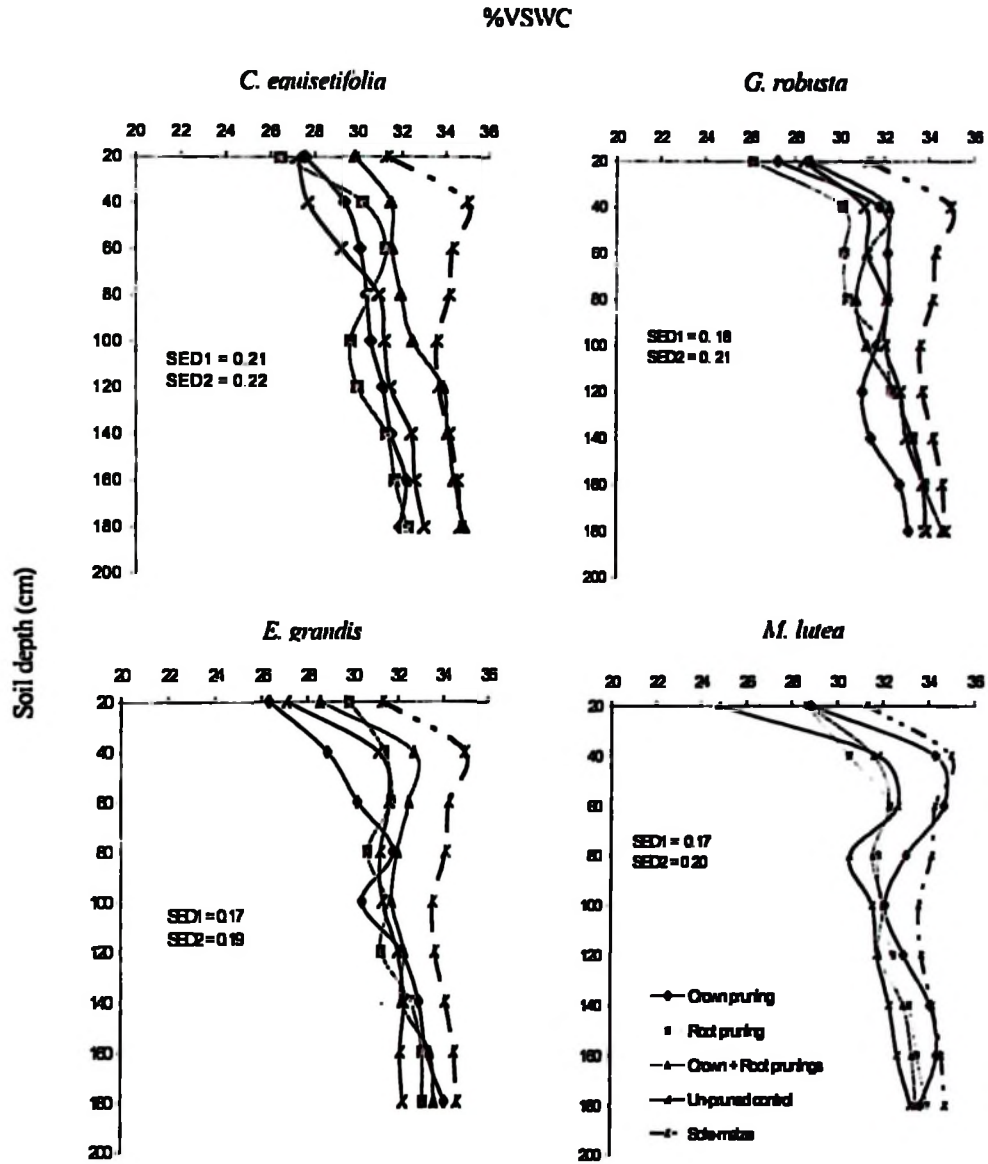

SED1 = Standard error of the means between depths in a treatment
 SED2 = Standard error of the means between treatments for a given depth of soil profile

Figure 4.3.4: Effect of soil depth on pooled mean volumetric soil water content (%) during the April-May long rain 2000 of the 3rd maize growing season at Siaya, western Kenya.

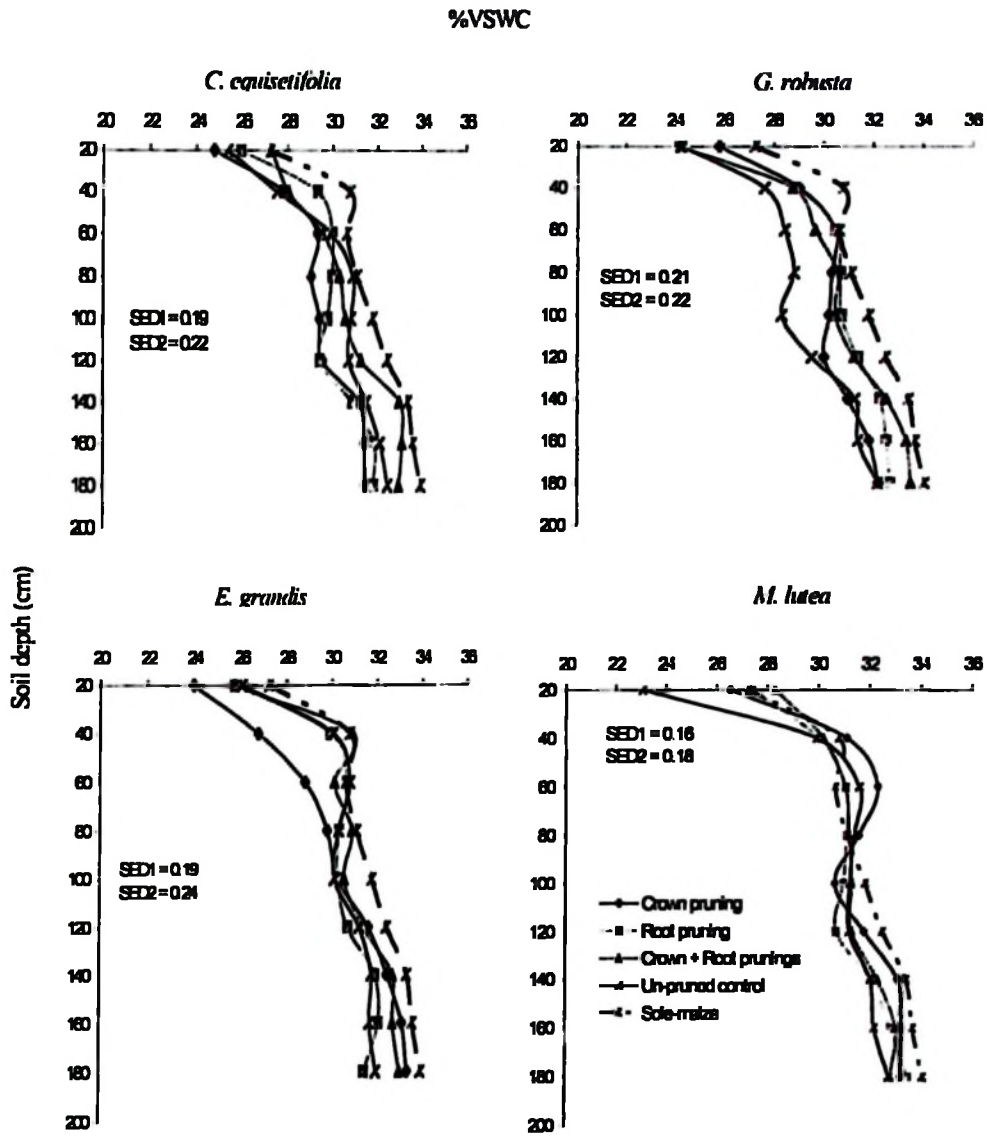

SED1 = Standard error of the means between depths in a treatment
 SED2 = Standard error of the means between treatments for a given depth of soil profile

Figure 4.3.5: Effect of soil depth on pooled mean volumetric soil water content (%) during the June-July long rain 2000 of the 3rd maize growing season at Siaya western Kenya.

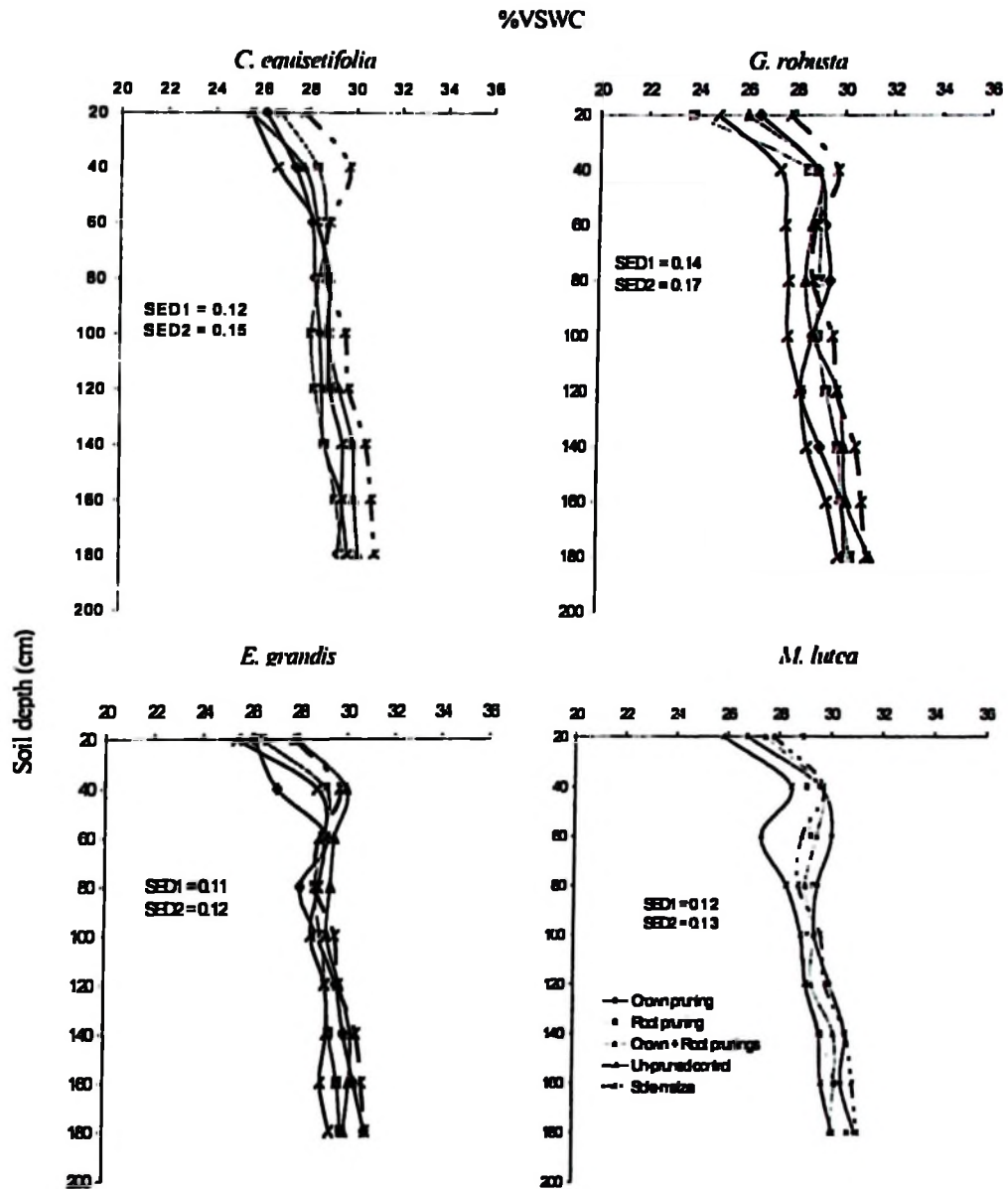

SED1 = Standard error of the means between depths in a treatment
 SED2 = Standard error of the means between treatments for a given depth of soil profile

Figure 4.3.6: Effect soil depth on pooled mean volumetric soil water content (%) during the September-January short rain 2000 of the 4th maize growing season at Siaya, western Kenya.

4.3.1.5 Effect of distance from tree lines on soil water content in relation to soil depth during long and short rains of 2000 as measured by neutron probe at Siaya, western Kenya.

The effect of distance from tree lines on %VSWC as well as its interactions with pruning treatments and tree species were not statistically ($P>0.05$) different (Table 4.3.8).

4.3.1.6 Seasonal changes in %VSWC at Siaya

Percent VSWC under tree plots significantly ($P<0.05$) differed between assessment occasions and overall trends of %VSWC over different cropping season pooled for all tree species and pruning treatments are present in (Figure 4.3.7). The trends of %VSWC followed the rainfall pattern presented in chapter 3 (Figure 3.2). Soil water under all pruning tree treatment plots was highly depleted during June- July and January-February periods but was the highest during the April-May long rains and October-November short rains (Figures 4.3.7 and 4.3.8). Seasonal soil water content under the different tree pruning treatments significantly differed ($P<0.05$) during the first two seasons of long and short rains in 1999 (Figure 4.3.8). The unpruned (control) tree plots had significantly ($P<0.05$) less %VSWC during the first two seasons. When the amount of rainfall received in the area was unusually low, compared to the other seasons, during the third season of long rain 1999, %VSWC ceased to show any significant ($P>0.05$) differences between tree pruning treatment (Figure 4.3.8).

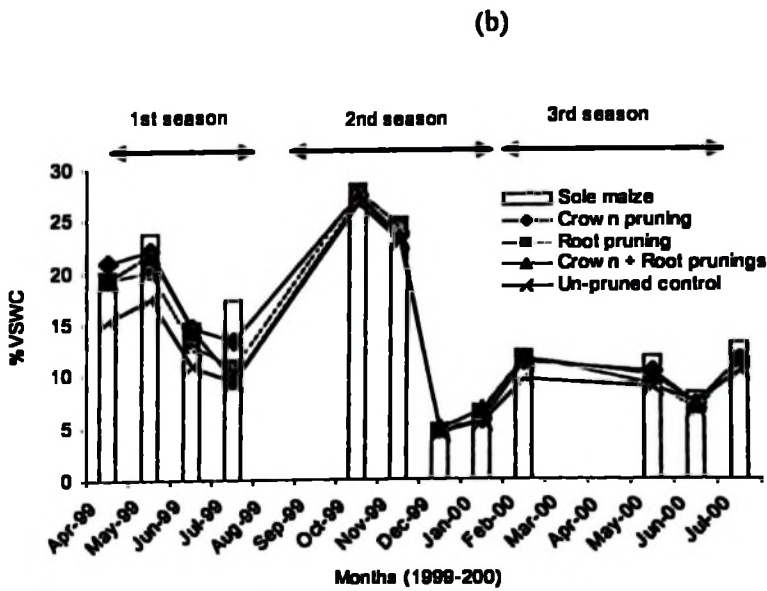
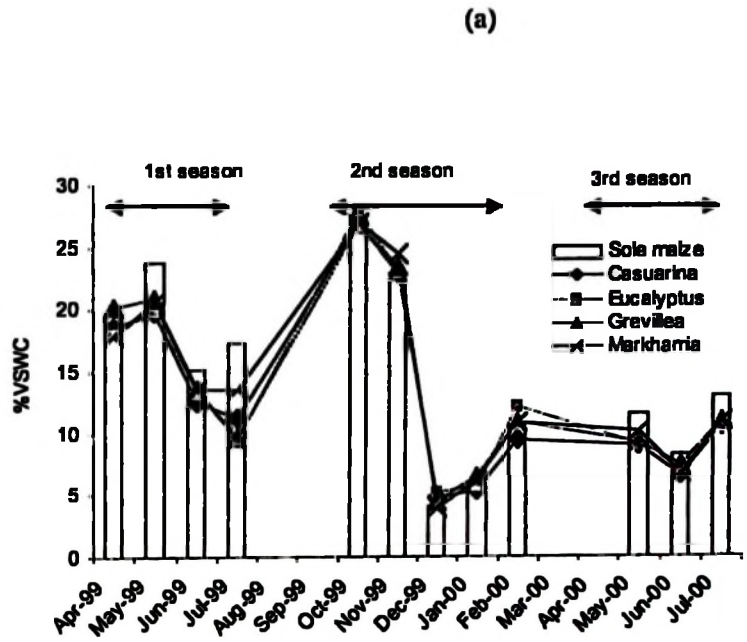

Figure 4.3.7: Trends of %VSWC pooled over (a) pruning treatments and (b) over species during the 3 maize growing season at Siaya, western Kenya.

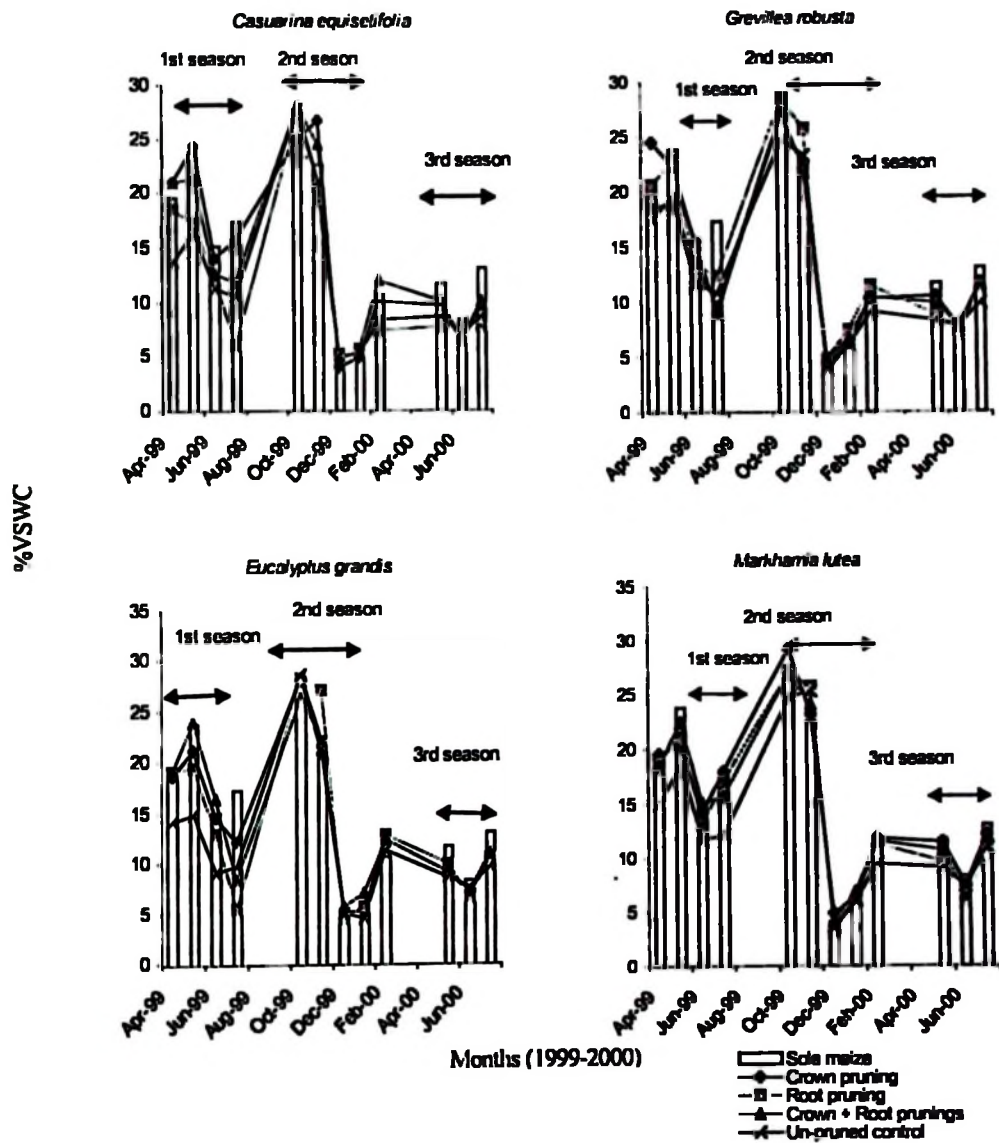

Figure 4.3.8: Effect of tree pruning on %VSWC trends for all soil depths over 3 maize growing seasons at Siaya, western Kenya.

4.3.1.7 Rainfall canopy throughfall of trees subjected to different pruning treatments

Analysis of variance of rainfall canopy interception for species, tree pruning and distance of rain gauges from the tree lines showed no significant differences ($P>0.05$) on all assessment occasions. Summaries of rainfall canopy interception for all the treatments at 1-m, 2-m from tree lines and in the open air are shown in Figure 4.3.9.

4.3.2 Nyabeda

Due to the narrow spacing between treatment plots at Siaya and the fact that there was no trenching between plots, except for the sole maize plots, it was assumed that interaction between plots may exist and may have biased the effects of root pruning studies, as tree roots of the different treatment plots may have intermingled from different directions.

The tree root pruning study carried out at Nyabeda, which had a relatively bigger plot size than Siaya (single tree rows) was assumed to facilitate evaluation of the effects of tree root pruning treatments on %VSWC, as compared to distance from tree lines.

4.3.2.1 Effects of root pruning of *G. robusta* boundary planted trees on %VSWC as measured by Neutron probe at Nyabeda, western Kenya.

Soil water measurement using neutron probe (due to limitation of thetaprobe availability, only neutron probe was used at Nyabeda site) commenced immediately after tree root pruning. However, due to technical problems soil water count by thetaprobe was not undertaken in Nyabeda.

There were significant ($P < 0.001$) differences between root pruning treatments on %VSWC on all the assessment occasions (Table 4.3.14). Sole maize plot always had the highest %VSWC. The one side pruned tree plots did not differ from the both sides un-pruned (control) tree plots while the other side un-pruned tree plot had the least %VSWC. During most part of the study period, %VSWC for all tree pruning treatments was the same but they all significantly differed from the sole maize plots (Tables, 4.3.14 and 4.3.15). See also Figure 4.3.10.

4.3.2.2 Changes in soil water content with soil depth as measured by neutron probe at Nyabeda

There were significant ($P < 0.001$) variations in %VSWC with soil depths and its interaction with root pruning treatments at all assessment occasions (Table 4.3.14). No significant ($P > 0.05$) interactions were observed between soil depths, pruning treatments and distances from tree line on all assessment occasions (Table 4.3.14).

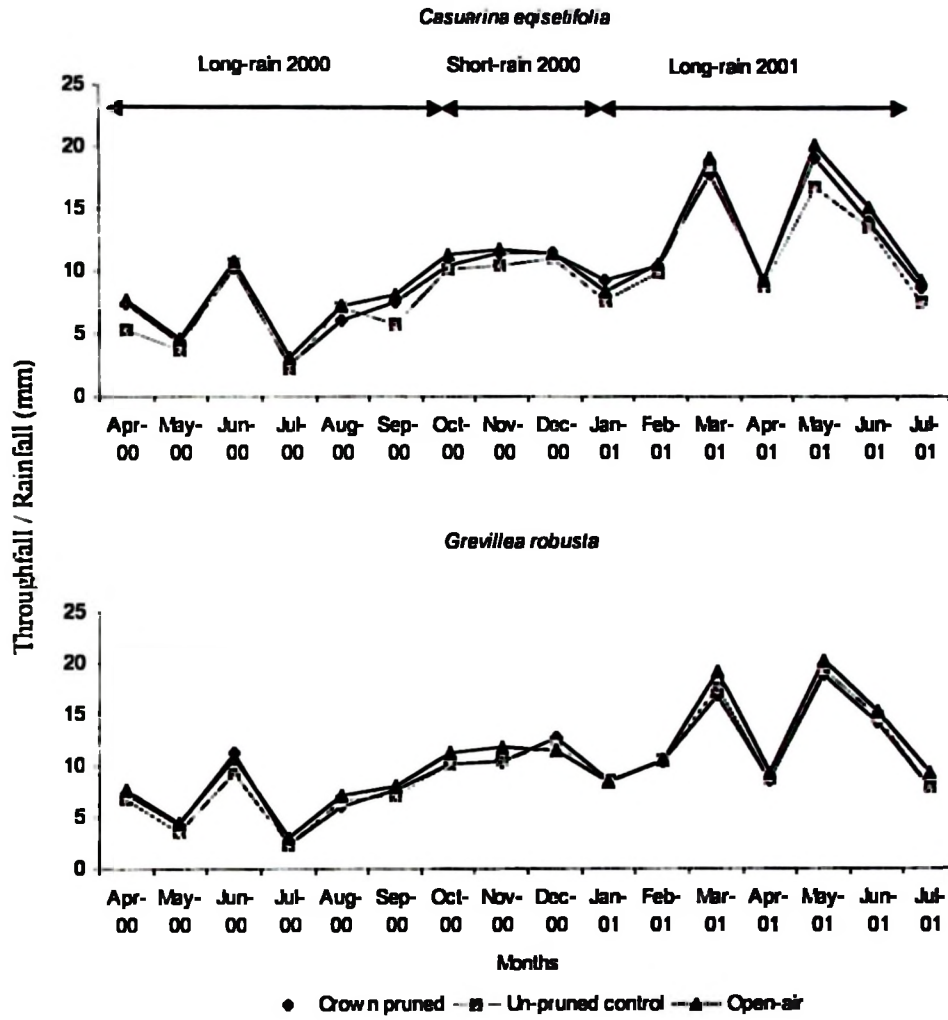

Figure 4.3.9: Mean monthly rainfall canopy throughfall as compared to the rainfall in an open air for *C. equisetifolia* and *G. robusta* crown pruned and un-pruned control tree plots over 3 maize growing seasons at Siaya, western Kenya.

Table 4.3.14: Summaries of probability values for greater F-ratio from ANOVA examining effects of root pruning treatments, soil depth and distance from tree lines and their interactions on %VSWC during the maize growing seasons of short rain of 1999, long rain of 2000 and short rain of 2000, at Nyabeda western Kenya.

Source of variation	Maize season – 1 (Short rain 1999)		Maize season – 2 (Long rain 2000)		Maize season – 3 (Short rain 2000)	
	October (wet)	January (dry)	April (wet)	July (dry)	October (wet)	January (dry)
Pruning (P)	0.0001**	0.002**	0.0001**	0.002**	0.0001**	0.0001**
Depths (DE)	0.0001**	0.0001**	0.0001**	0.0001**	0.0001**	0.0001**
Distance (D)	0.0001**	0.0001**	0.0001**	0.0001**	0.0001**	0.0001**
P x DE	0.052	0.757	0.337	0.189	0.171	0.379
P x D	0.000**	0.016	0.0001**	0.0001**	0.0001**	0.0001**
DE x D	0.743	0.868	0.994	0.979	0.978	0.082
P x DE x D	0.996	1.000	0.983	0.999	1.000	1.000

* = Significant at $p < 0.05$ and ** = Significant at $p < 0.001$.

Table 4.3.15: Effect of tree root pruning on volumetric soil water content (%) pooled for all depths and distances from tree lines for January 2000 to January 2001 period at Nyabeda, western Kenya.

	One-side pruned	The other side un-pruned	Both sides un- pruned control	Sole maize	SED	Prob>F- ratio
January	33.01 ^c	33.72 ^b	33.78 ^b	36.36 ^a	0.14	0.0001
February	33.95 ^c	33.54 ^d	34.91 ^b	36.70 ^a	0.15	0.0001
March	34.16 ^c	33.08 ^c	34.10 ^b	36.45 ^a	0.13	0.0001
May	34.40 ^b	33.29 ^c	34.33 ^b	37.32 ^a	0.13	0.0001
June	34.31 ^b	33.80 ^c	34.47 ^b	36.42 ^a	0.11	0.0001
July	33.04 ^c	32.92 ^c	33.49 ^b	35.47 ^a	0.09	0.0001
August	33.04 ^c	32.92 ^c	33.49 ^b	35.47 ^a	0.09	0.0001
September	33.85 ^c	33.27 ^d	34.16 ^b	36.05 ^a	0.09	0.0001
October	35.66 ^a	34.00 ^c	35.11 ^b	35.89 ^a	0.16	0.0001
November	33.96 ^c	33.46 ^d	34.24 ^b	35.94 ^a	0.10	0.0001
December	36.37 ^b	35.52 ^c	36.35 ^b	38.51 ^a	0.08	0.0001
January	31.65 ^c	30.97 ^d	32.09 ^b	33.07 ^a	0.13	0.0001

Mean values in same column or the same row followed by different letters are significantly different ($p < 0.05$), SED = standard error of the differences of means.

Results of the effect of boundary planted *G. robusta* on soil water, with reference to soil depth, during the first three seasons at Nyabeda are presented in Table 4.3.16. The results show that sole maize plots always had more %VSWC in all assessment depths as compared to the root pruned tree plots. All root pruned tree plots had lower water content below 40-cm soil depth.

The both sides unpruned (control) tree plots had significantly less %VSWC in the upper 20 cm soil depth. Soil water content was high between 40-80 cm soil depths for all root pruned tree plots, during the first two seasons. However, the unpruned (control) tree plots had more water at 60-cm depth compared to the root pruned tree plots. Soil profile with one side unpruned tree plots had the lowest water content within 40-200 cm soil depths.

The %VSWC for the unpruned (control) tree plots and one side pruned tree plots was similar below 60-cm depth, during the first and the second maize cropping seasons (Table 4.3.16). Percent VSWC, during the third maize growing season i.e. short rain 2000, was higher in the top 0-20 cm for the one-side root pruned treatments while the other side un-pruned always resulted in less %VSWC than the both side un-pruned (control) tree plots.

Table 4.3.16: Effect of soil depth on mean %VSWC pooled for all distances from the tree line and pruning treatments during the 3 maize cropping seasons at Nyabeda, western Kenya.

First season short rain (September - January 1999)				
Soil depth (cm)	One-side root pruned	The other side un-pruned	Both sides un-pruned control	Sole Maize
0-20	25.32	27.11	24.77	30.15
20-40	33.87	34.24	33.66	36.86
40-60	34.30	34.49	35.37	38.08
60-80	34.37	35.10	35.84	38.09
80-100	33.70	34.48	34.82	38.49
100-120	33.55	34.63	34.55	38.65
120-140	33.81	34.36	34.57	36.19
140-160	33.71	33.84	34.83	35.95
160-180	33.79	33.24	34.57	34.74
180-200	33.76	34.49	34.46	35.55
Mean	33.01	33.72	33.78	36.36
Lsd $p < 0.05$ For differences between mean %VSWC with depths of soil profile = 0.32				
Second season long rain (March - August 2000)				
Soil depth (cm)	One-side root pruned	The other side un-pruned	Both sides un-pruned control	Sole Maize
0-20 cm	30.73	32.22	30.81	36.15
20-40 cm	36.47	34.88	36.64	39.17
40-60 cm	36.37	35.28	37.32	40.36
60-80 cm	36.21	33.91	35.74	39.24
80-100 cm	34.74	32.93	34.99	38.46
100-120 cm	34.32	32.61	34.15	36.46
120-140 cm	34.05	32.85	33.58	35.19
140-160 cm	33.51	32.45	33.56	34.46
160-180 cm	33.61	32.53	33.14	34.53
180-200 cm	33.96	33.23	33.38	37.32
Mean	34.40	33.29	34.33	37.32
Lsd $p < 0.05$ For differences between mean %VSWC with depths of soil profile = 0.29				
Third season short rain (September - January 2000)				
Soil depth (cm)	One-side root pruned	The other side un-pruned	Both sides un-pruned control	Sole Maize
0-20	31.81	29.87	30.14	32.78
20-40	34.73	34.17	34.67	37.50
40-60	34.98	34.63	35.52	37.36
60-80	34.42	34.06	35.53	37.24
80-100	33.81	33.16	35.12	37.47
100-120	33.56	33.09	34.53	36.81
120-140	33.90	33.52	34.02	37.23
140-160	33.70	33.09	34.26	37.25
160-180	33.60	33.48	33.80	35.21
180-200	33.99	33.85	34.02	37.58
Mean	33.85	33.28	34.16	36.63
Lsd $p < 0.05$ For differences between mean %VSWC with depths of soil profile = 0.25				

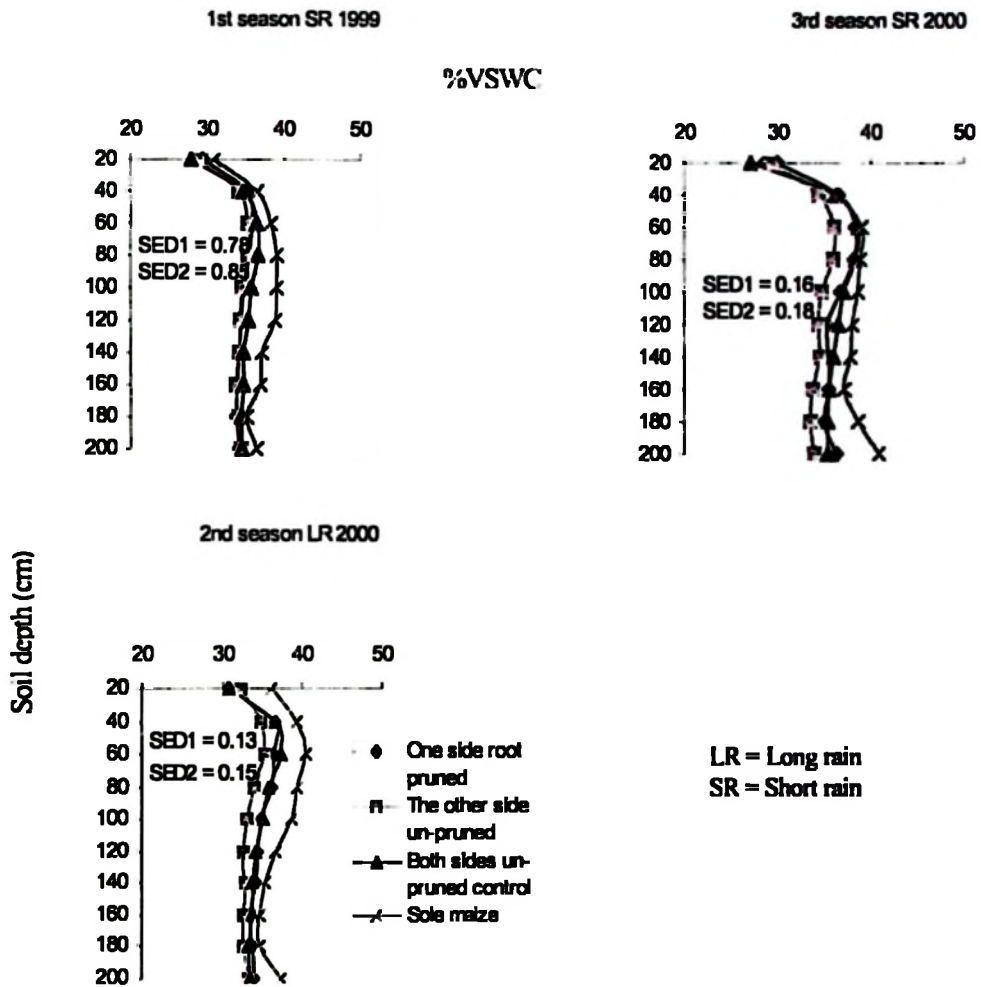

SED1 = Standard error of the means between depths in a treatment.
 SED2 = Standard error of the means between treatments for a given depth of soil profile.

Figure 4.3.10: Effects of soil depth and tree root pruning on percent volumetric soil water content (%) pooled for all distances from *G. robusta* tree line during the short rain 1999, long rain 2000 and short rain 2000 at Nyabeda, western Kenya.

4.3.2.3 Effect of increasing distance from tree lines on soil water content over 3 maize growing seasons at Nyabeda, western Kenya

Increasing distance from the tree line significantly (<0.001) increased %VSWC during all the measurement occasions (Figure 4.3.11). There were also significant ($P<0.001$) interaction effect between tree pruning treatments and increasing distance from tree lines on %VSWC during all the three maize cropping seasons (Table 4.3.12).

4.3.2.4 Seasonal changes in %VSWC at Nyabeda

The overall trends of %VSWC over different cropping seasons pooled for all soil depths and distance from tree lines followed the rainfall pattern presented in chapter 3. The results indicate that %VSWC under all tree pruning treatments increased when it rained (November-May) and gradually decreased (June-August) when it stopped (Figure 4.3.12).

During all the study period, %VSWC under the root pruned tree plots followed similar trends but they all significantly ($P<0.05$) differed from the sole maize plots. The sole maize plots had the highest %VSWC throughout the measurement periods while soils under the one side unpruned tree plots had the lowest (Figure 4.3.12).

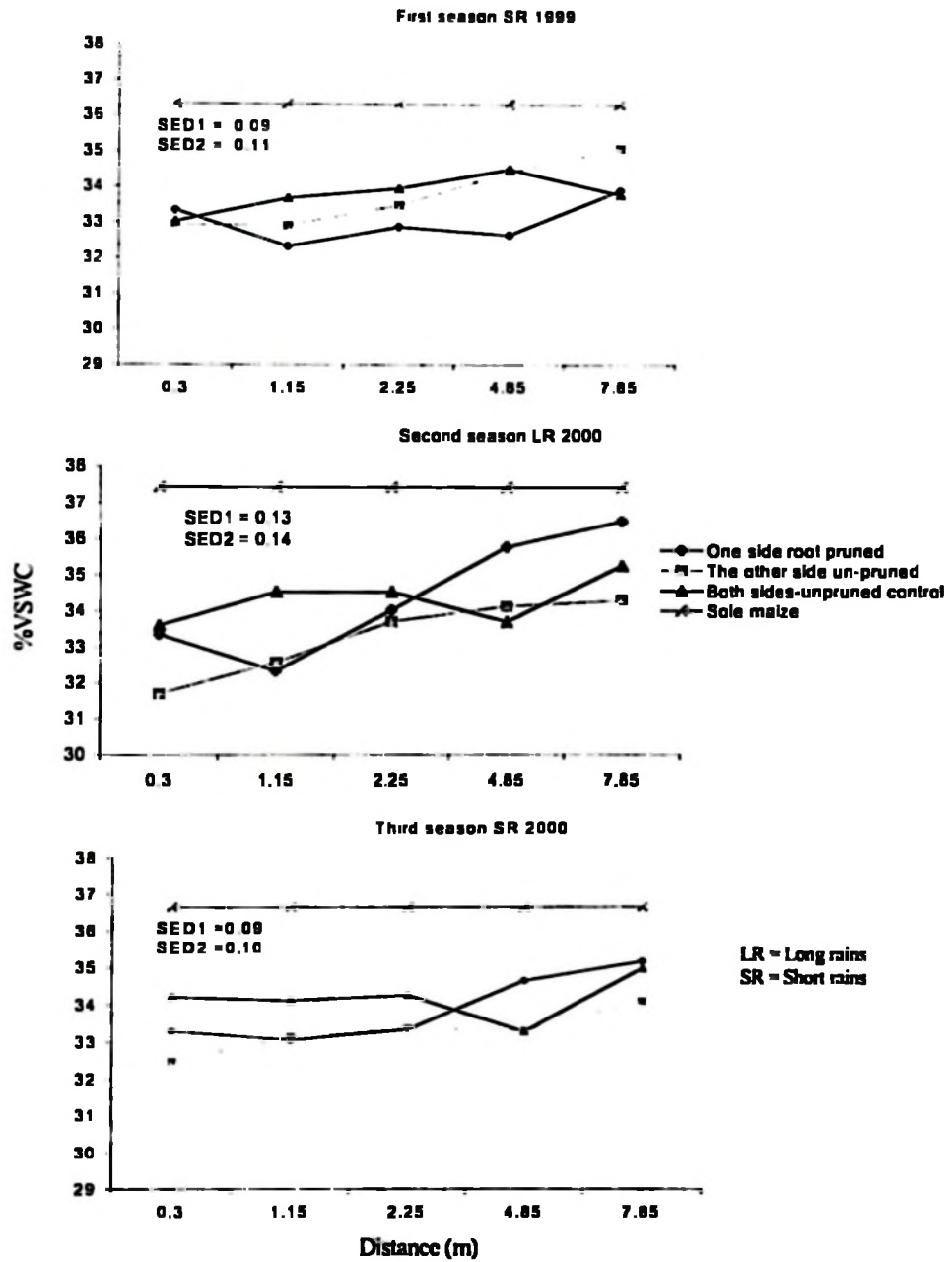

SED1 = Standard error of the means between distances in a treatment
 SED2 = Standard error of the means between treatments for a given distance.

Figure 4.3.11: Effect of distance and tree root pruning on percent volumetric soil water content (%) pooled for all depths during the short rain 1999, long rain 2000 and short rain 2000 at Nyabeda, western Kenya.

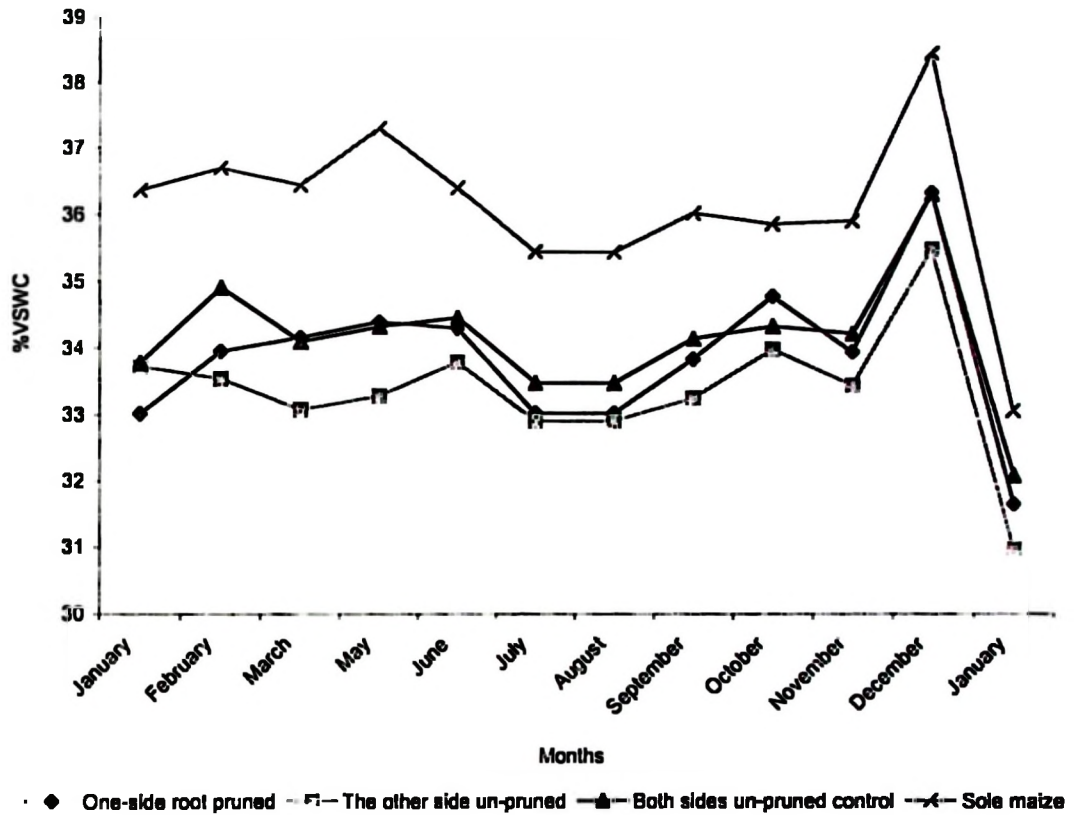

Figure 4.3.12: Mean trends of %VSWC pooled for all soil depths and distances from tree line over three seasons at Nyabeda, western Kenya.

4.4 Sap flow

Due to limitations of the availabilities of sap flow equipments, only two species were included in this study, *C. equisetifolia* and *G. robusta* at Siaya and *G. robusta* at Nyabeda. The sap flow equipment was available almost two years after the pruning treatments were applied at Siaya and after about one year at Nyabeda and therefore the result presented in this section would have been different if assessments were done immediately after application treatment.

4.4.1 Siaya

4.4.1.1 Sap flow in *C. equisetifolia*

Diurnally, sap flow increased from 7 – 10 hours, remained constant to about 15 hours then it started to decrease and it stabilized at about 19 hours, with gradual decrease before and after those hours in all treatment tree plots (Figure 4.4.1). There were, however, significant ($P = 0.0001$) differences in sap flow (cm/hr) between the pruning treatments. Sap flow was the highest in the root-pruned trees while the crown pruned trees exhibited the least sap flow (Figure 4.4.1).

4.4.1.2 Sap flow in *G. robusta*

Diurnal sap flow started to increase at 6 hours, attained maximum at about 11 hours and started to decline at 12 hours. The sap flow remained constant starting from 15-16 hours. Two years after tree pruning, crown and crown plus root pruned *G. robusta* trees significantly decreased transpiration rate compared to root pruned and the unpruned (control) trees. There was significant ($P = 0.0001$) variation in sap flow between pruning treatments (Figure 4.4.2).

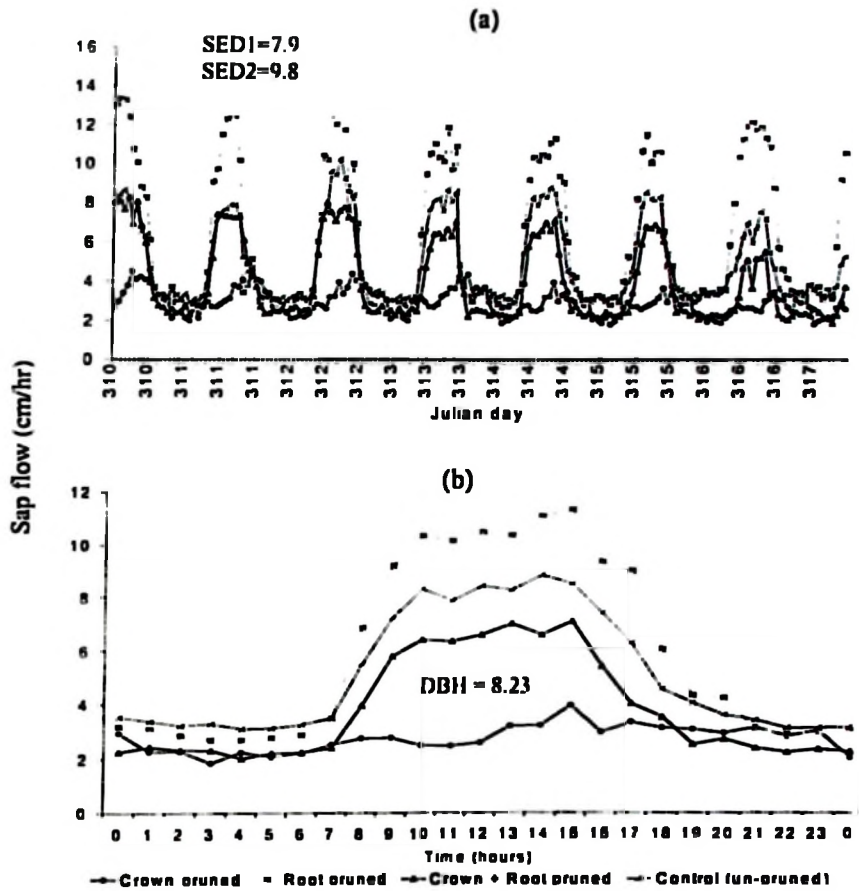

SED1 = Standard error of the means between time in a treatment
 SED2 = Standard error of the means between treatments for a given time.

Figure 4.4.1: Trends of transpiration rates averaged for (a) all days and (b) hours/day for *C. equisetifolia* during the 4th cropping season (4 seasons after tree pruning) i.e. short rain 2000, 2 years after pruning, at Siaya, western Kenya.

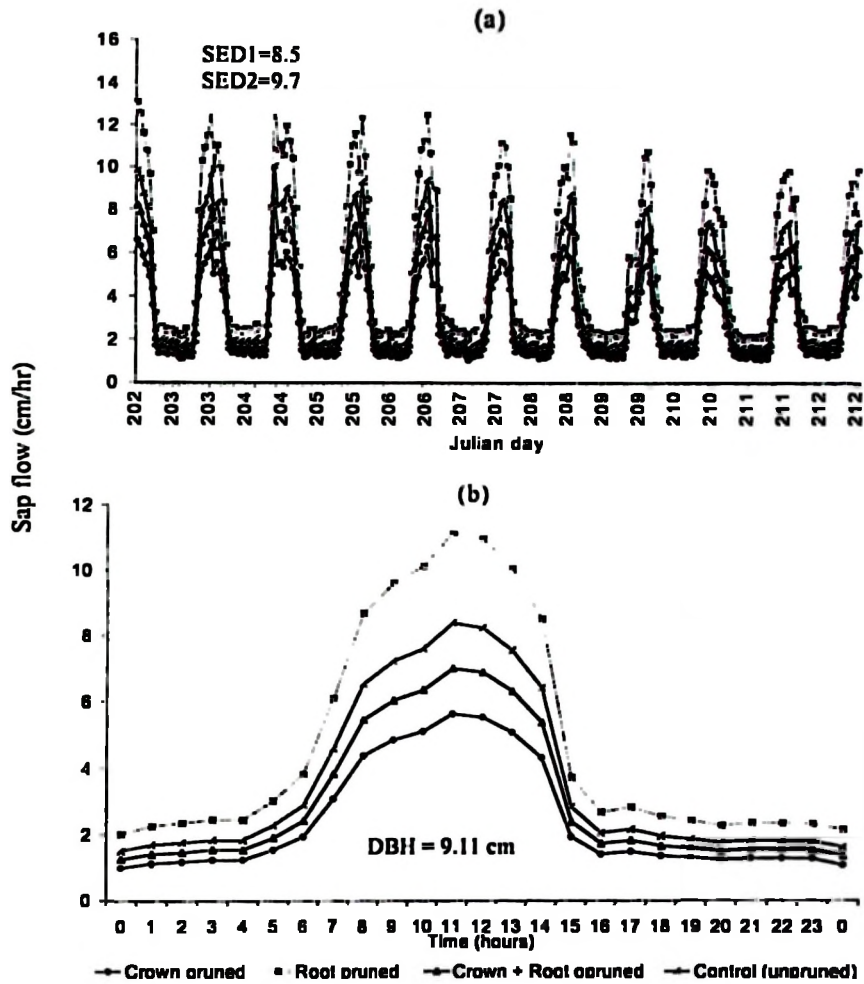

SED1 = Standard error of the means between time in a treatment.

SED2 = Standard error of the means between treatments for a given time.

Figure 4.4.2: Trends of transpiration rates averaged for (a) all days and (b) hours/day for *G. robusta* during the 4th cropping season (4 seasons after tree pruning) i.e. short rain 2000, 2 years after pruning, at Siaya, western Kenya.

4.4.2 Nyabeda

Diurnal variation in Sap flow (transpiration) per tree per hour for boundary planted *G. robusta* at Nyabeda was analyzed for the two treatments, one-side root pruned and unpruned (control) plots.

There was a significant difference in sap flow between the two treatments and the results showed that when trees are pruned in only one side and the other side is left unpruned, trees will have a higher transpiration rate per hour than when trees are unpruned on both sides.

4.5 Light interception

Studies on light interception were carried out to determine whether the amount of shade cast by the different trees was affected by the different pruning treatments and its relation with maize growth and yield. This section presents the results on light that was incident on maize canopy and that was intercepted by maize crops, as influenced by the presence of trees and their pruning treatments.

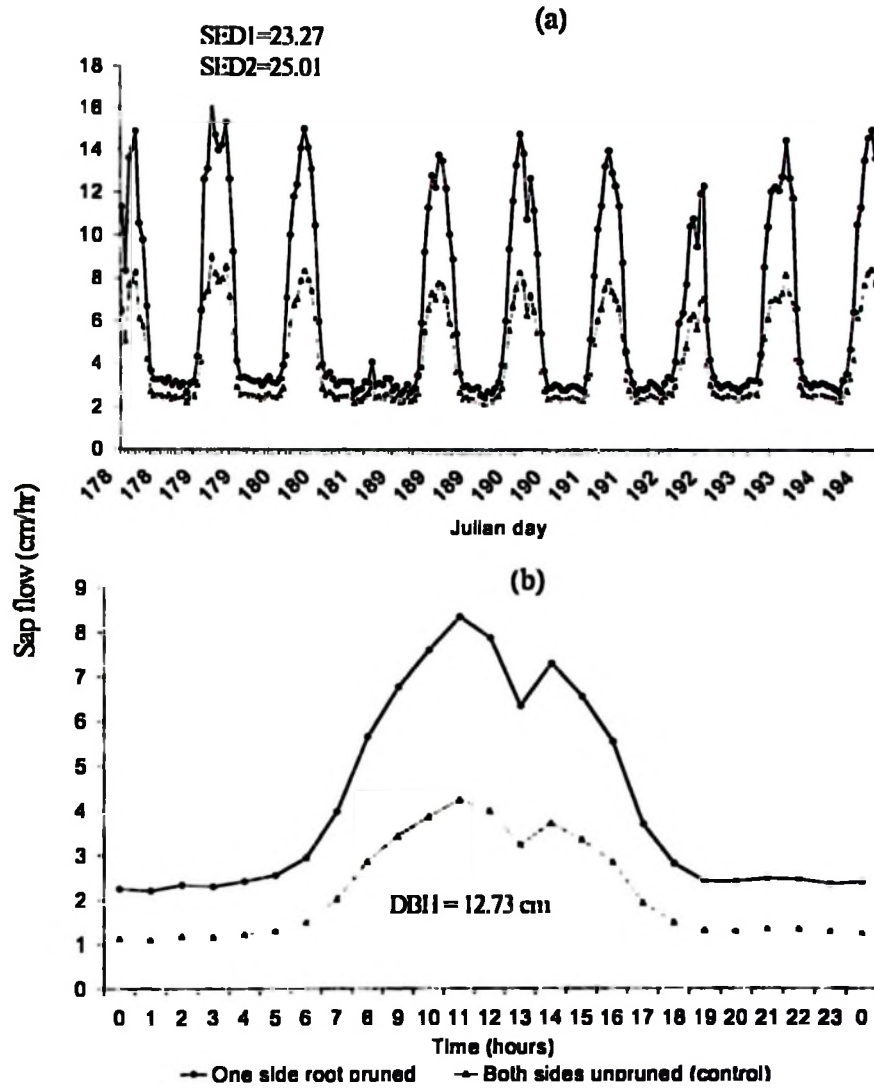

SED1 = Standard error of the means between time in a treatment.
 SED2 = Standard error of the means between treatments for a given time.

Figure 4.4.3: Trends of transpiration rates averaged for all (a) days and (b) hours/day for *G. robusta* during the 2nd cropping season (2 seasons after root pruning) i.e. long rain 2000 at Nyabeda, western Kenya.

4.5.1 Effects of boundary trees on fraction of incoming PAR incident on the maize canopy

The mean fraction of the incoming PAR that was incident on the maize canopy during the first (long rain in March – May 1999, immediately after tree pruning was imposed) and the fourth (September–November short rain in 2000) maize cropping seasons are shown in Figure 4.5.1. Tree species, pruning treatments and rows of maize from tree lines; and interaction of species with pruning treatments as well as interaction of pruning treatments with rows, during the 1st and 4th seasons, significantly ($P < 0.0001$) affected the fraction of incoming PAR that was reaching the maize canopy when compared to the sole maize.

However, the interaction of species, pruning treatments and rows were significantly affected only during the first season, 1999 (Table 4.5.1 and Figure 4.5.1). The overall reduction in incident PAR for all the pruning treatments and maize rows during the first season was 33%, 46%, 35% and 25% under *C. equisetifolia*, *E. grandis*, *G. robusta* and *M. lutea* respectively. During the 4th maize cropping season, *C. equisetifolia* reduced the incoming PAR by 36%, *E. grandis* by 47%, *G. robusta* by 38% and *M. lutea* 34%. The fraction of light that was reduced by presence of trees on maize canopy increased from the first to the 4th maize cropping season (Figure 4.5.1a and 4.5.1b).

Both crown and crown plus root pruning significantly ($P < 0.001$) reduced the effects of tree shading on crops and increased the fraction of light that was reaching the maize canopy (Table 4.5.1, Figure 4.5.1a and 4.5.1b). In order to show effects of crown pruning on light, the light data which was taken immediately after pruning and at the end of this study (after 4 cropping seasons) are presented (Figure 4.5.1a and 4.5.1b). Since light readings were found to vary within short distance under the tree canopy (McIntyre *et al.*, 1996), the average of seven measurements was used in this study.

4.5.2 Fraction of PAR intercepted by the maize crop foliage

The mean fraction of the incoming PAR that was intercepted by the maize crop during the four cropping seasons was significantly ($P < 0.05$) different for the main effects of species, tree pruning and rows of maize from the tree lines; and also for the interactions of species and tree pruning during all the assessment occasions while interactions of species rows and species, pruning and rows were significant during the first assessment occasion (Table 4.5.2b).

The mean fraction of PAR intercepted by the foliage of the maize crop was significantly lower in the tree plots when compared to the sole maize plot for all the measurements taken in all the four cropping seasons (Table 4.5.3).

Table 4.5.1: Light intercepted by 4 boundary planted tree species, immediately after pruning, during the first maize cropping season of the long rain in 1999 at Siaya, western Kenya.

Species	Treat.	Open PAR (Mj m ⁻²)	Under tree PAR (Mj m ⁻²)	PAR Under maize (Mj m ⁻²)	%PAR intercepted by trees	%PAR reaching maize canopy	%PAR intercepted by maize
<i>C. papuana</i>	Crown pruning	1689	1357	547	19.94 ^e	80.06 ^a	59.69 ^d
	Root pruning	1530	827	478	45.82 ^c	54.18 ^d	42.20 ^f
	Crown + Root	1705	1438	653	16.06 ^d	83.94 ^a	54.99 ^b
	Control	1620	913	497	35.3 ^b	64.70 ^c	45.56 ^e
Mean	1636	1134	544	29.28	70.72	52.03	
	(11)	(8)	(10)	(1.2)	(0.89)	(0.5)	
Prob>F-ratio	0.0001	0.0001	0.0001	0.0001	0.0001	0.0001	
<i>E. grandis</i>	Crown pruning	1714	1257	587	26.32 ^c	73.68 ^a	53.30 ^d
	Root pruning	1574	775	335	51.43 ^a	48.57 ^d	56.77 ^c
	Crown + Root	1627	1173	499	28.15 ^b	71.85 ^b	57.46 ^c
	Control	1489	713	451	52.32 ^a	47.68 ^e	36.75 ^f
Mean	1601	979	468	39.56	60.44	52.20	
	(13)	(15)	(9)	(1.1)	(0.9)	(0.7)	
Prob>F-ratio	0.0001	0.0001	0.0001	0.0001	0.0001	0.0001	
<i>G. robusta</i>	Crown pruning	1700	1236	605	27.68 ^c	72.32 ^a	51.05 ^d
	Root pruning	1621	793	393	48.98 ^b	51.02 ^d	50.44 ^e
	Crown + Root	1562	1209	504	24.05 ^d	75.95 ^a	55.11 ^c
	Control	1531	656	306	56.59 ^a	43.41 ^e	53.35 ^e
Mean	1603	974	452	39.33	60.67	53.99	
	(12)	(9)	(7)	(0.8)	(0.9)	(0.4)	
Prob>F-ratio	0.0001	0.0001	0.0001	0.0001	0.0001	0.0001	
<i>M. hirta</i>	Crown pruning	1640	1052	402	36.37 ^c	63.63 ^a	61.79 ^d
	Root pruning	1612	918	404	43.01 ^b	56.99 ^d	55.99 ^e
	Crown + Root	1533	1159	456	25.79 ^d	74.21 ^a	60.66 ^c
	Control	1687	875	473	47.11 ^a	52.89 ^c	45.94 ^f
Mean	1618	1001	434	38.07	61.63	56.64	
	(9)	(7)	(4)	(0.6)	(0.5)	(0.4)	
Prob>F-ratio	0.0001	0.0001	0.0001	0.0001	0.0001	0.0001	

Numbers in parenthesis are standard error of the mean of 6 observations. Prob > F-ratio = Probability value from ANOVA output and Fisher's F test. Values in same column within species followed by different letters are significantly different ($p < 0.05$)

Maize plants in the unpruned (control) and root only pruned trees intercepted significantly ($P < 0.001$) less PAR than the crown pruned and crown plus root pruned trees during the first season of the long rain 1999 (April-June). The crown and crown plus root pruned trees of all species intercepted statistically the same PAR as the sole maize (Figure 4.5.2).

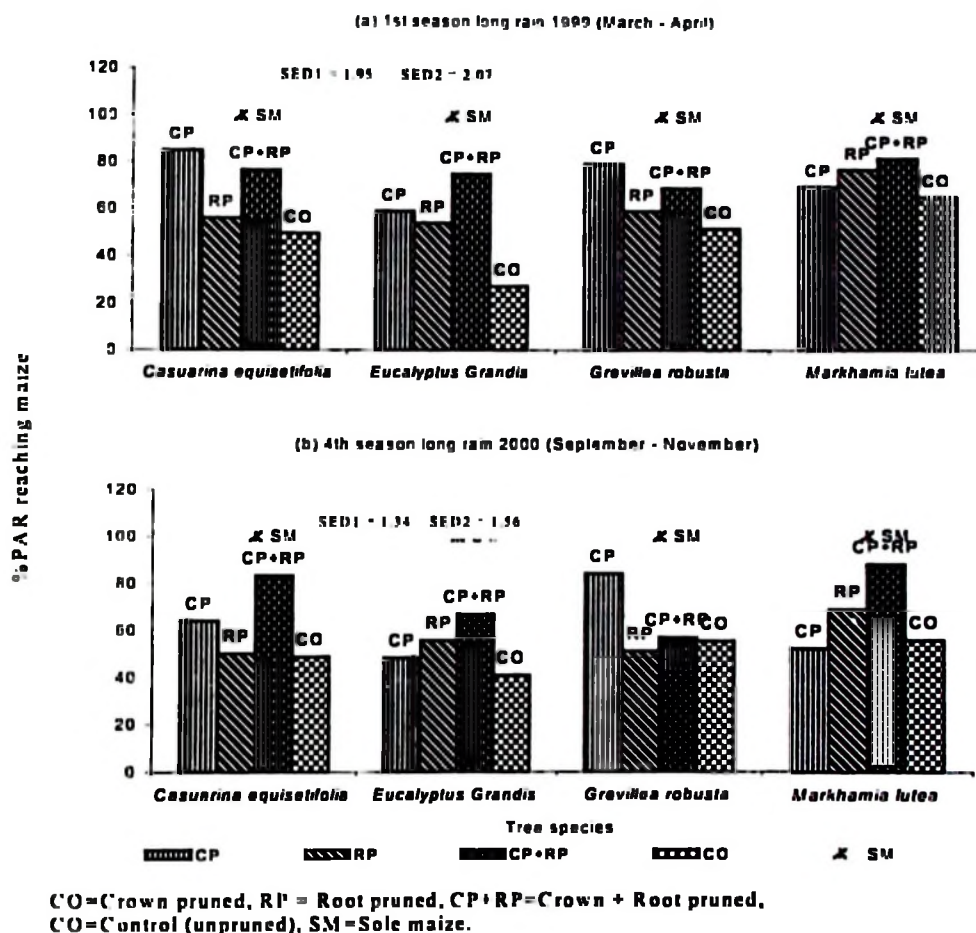

SED1 = Standard error of the means between %PAR in a species

SED2 = Standard error of the means between %PAR for a given species.

Figure 4.5.1: Effect of trees and pruning treatments on the mean (4 measurements) fraction of incoming PAR reaching the maize crop for (a) March – May 1999 and (b) September – November 2000 cropping seasons at Siaya, western Kenya.

The situations, remained unchanged during the second season of the short rain of 1999 (October-November) where the crown and crown plus root pruned treatments resulted in higher light interception compared to the unpruned (control) plots under all tree species but was statistically lower than the sole maize plot (Figure 4.5.3).

Table 4.5.2: Probability values for greater F-ratio for ANOVA of the effect of tree species, pruning treatments and rows of maize from tree lines and their interactions on PAR interception by trees (a) and by Maize (b) at Siaya, western Kenya.

Source	LR-1999	SR-1999	LR-2000	SR-2000
(a)				
Species (S)	0.000**	0.000**	0.000**	0.048
Pruning (P)	0.000**	0.000**	0.000**	0.000**
Rows (R)	0.000**	0.000**	0.000**	0.000**
S x P	0.000**	0.000**	0.000**	0.001**
S x R	0.050*	0.055	0.068	0.213
S x P x R	0.005*	0.023	0.097	0.465
(b)				
Species (S)	0.000**	0.000**	0.000**	0.098
Treatments (P)	0.000**	0.000**	0.000**	0.000**
Rows (R)	0.000**	0.000**	0.000**	0.000**
S x P	0.000**	0.000**	0.000**	0.001**
S x R	0.045*	0.058	0.087	0.541
S x P x R	0.003*	0.065	0.099	0.782

** = significant at $p < 0.001$ and * = significant at $p < 0.05$; LR=Long rains, SR=Short rains

Table 4.5.3: Mean (all pruning treatments combined) fractional light intercepted by maize crops during the 4 cropping seasons at Siaya, western Kenya.

	LR-1999	SR-1999	LR-2000	SR-2000
<i>C. equisetifolia</i>	0.59 ^c	0.64 ^b	0.46 ^b	0.58 ^a
<i>E. grandis</i>	0.59 ^c	0.65 ^b	0.52 ^a	0.51 ^b
<i>G. robusta</i>	0.56 ^b	0.63 ^b	0.44 ^b	0.57 ^a
<i>M. lutea</i>	0.61 ^a	0.69 ^a	0.45 ^b	0.60 ^a
Lsd	0.03	0.04	0.03	0.04
Sole maize	0.66	0.76	0.66	0.74

Values in the same column followed by different letters are significantly different ($P < 0.05$), Lsd = Least significant difference.

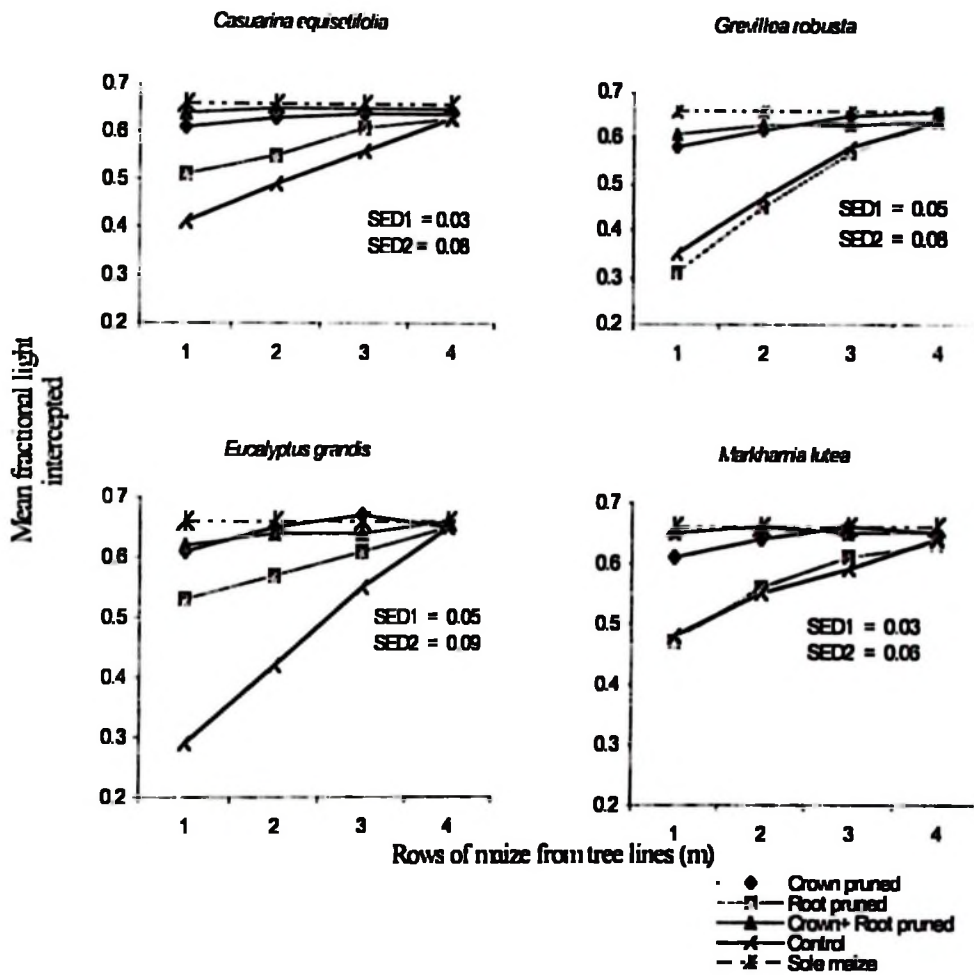

SED1 = Standard error of the means between rows in a treatment
 SED2 = Standard error of the means between treatments for a given row.

Figure 4.5.2: Effects of tree pruning on the mean PAR fractional interception by maize foliage (average of 5 measurements) for April-May 1999 at Siaya, western Kenya.

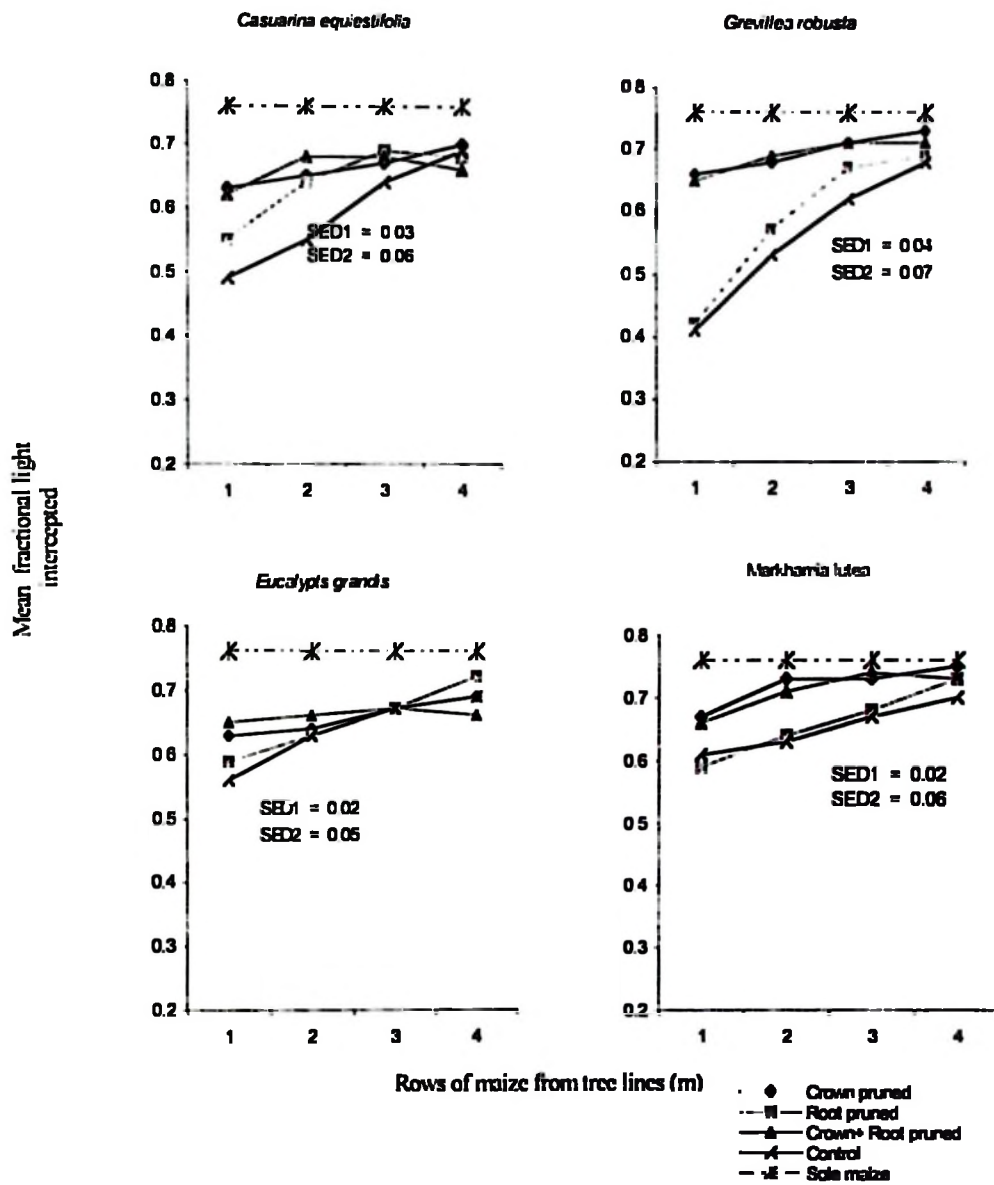

SED1 and SED2 as defined in Figure 4.5.2

Figure 4.5.3: Effects of tree pruning on the mean PAR fractional interception by maize foliage (average of 4 measurements) for October-November 1999 at Siaya, western Kenya.

During the third cropping season i.e. the long rain in 2000, crown pruned and crown plus root pruned *C. equisetifolia* plots showed significantly higher PAR interception while the root only pruned and the unpruned (control) plots had statistically the same but lower light interception than the crown and crown plus root pruned plots. *Eucalyptus grandis* unpruned (control) plot intercepted significantly less PAR compared to all the other treatments which were statistically the same. Crown and crown plus root pruned plots of *G. robusta* intercepted significantly higher PAR than its unpruned (control) plots. For *M. lutea*, unpruned (control) plots resulted in significantly lower PAR interception as compared to the other three pruning treatments (Figure 4.5.4).

The influence of rows of maize from the line on the interception of PAR is shown in Figures 4.5.2, 4.5.3, 4.5.4 and 4.5.5. Trees and treatment plots resulted in statistically different PAR by rows up to 3 m from tree line. Light interception increased as rows of maize increased from 1 m to 3 m (Figure 4.5.1). No significant differences were noted for PAR from 3 – 4 m in all the measurement occasions.

During the fourth cropping season of the short rain in 2000 PAR under *C. equisetifolia* was higher in the crown and crown plus root pruned plots. *Eucalyptus grandis* showed no significant ($P < 0.05$) differences among its all pruned plots. *Grevillea robusta* had significantly ($P < 0.05$) higher PAR in its crown pruned plot only. All the other treatment plots of *G. robusta* were statistically ($P > 0.05$) the same as the control plot.

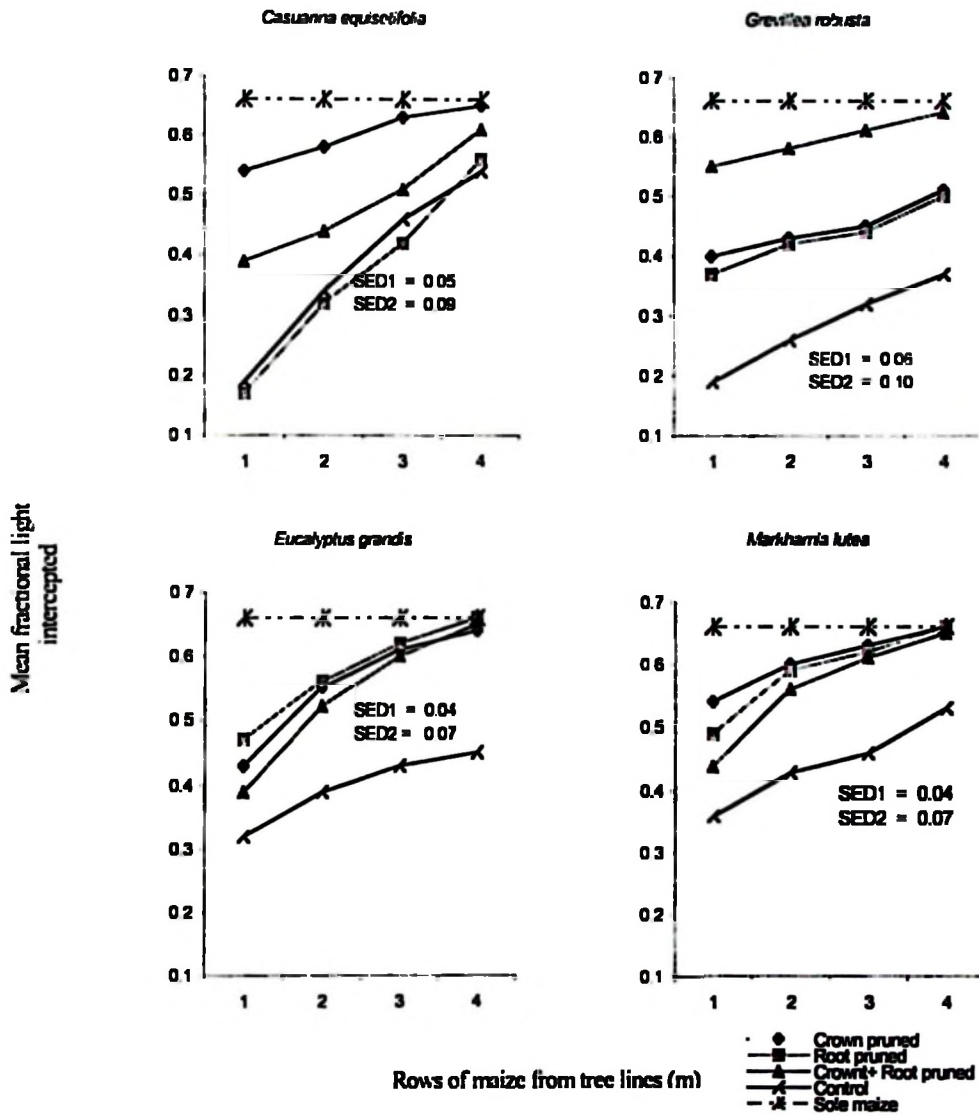

SED1 and SED2 as defined in Figure 4.5.2.

Figure 4.5.4: Effects of tree pruning on the mean PAR fractional interception by maize foliage (average of 5 measurements) for April-May 2000 at Siaya, western Kenya.

Markhamia lutea had significantly ($P < 0.05$) less PAR in the unpruned (control) and root pruned plots as compared to the other two treatments (crown and crown plus root pruned plots). The crown and crown plus root pruned *M. lutea* tree plots were statistically ($P > 0.05$) the same and had significantly higher PAR than the root pruned and the unpruned (control) tree plots (Figure 4.5.5).

In general, for all species: sole maize crop had highest light interception while the unpruned (control) had least light interception. For *C. equisetifolia* and *G. robusta*, crown and crown plus root pruning treatments intercepted higher PAR than root pruning treatments. For *E. grandis* and *M. lutea*, pruned trees intercepted more or less similar PAR.

4.6 Effect of tree pruning on growth and yield of maize

Maize growth and yield were monitored under the pruned trees in Siaya and Nyabeda sites. Results of maize growth and yields at Siaya are presented in section 4.6.1 while those at Nyabeda are presented in section 4.6.2. There were 5 cropping seasons for Siaya and 4 seasons for Nyabeda (Chapter 3 Tables 3.2 and 3.3). The pruning treatments were imposed in March 1999 long rain at Siaya and in September 1999 short rain at Nyabeda.

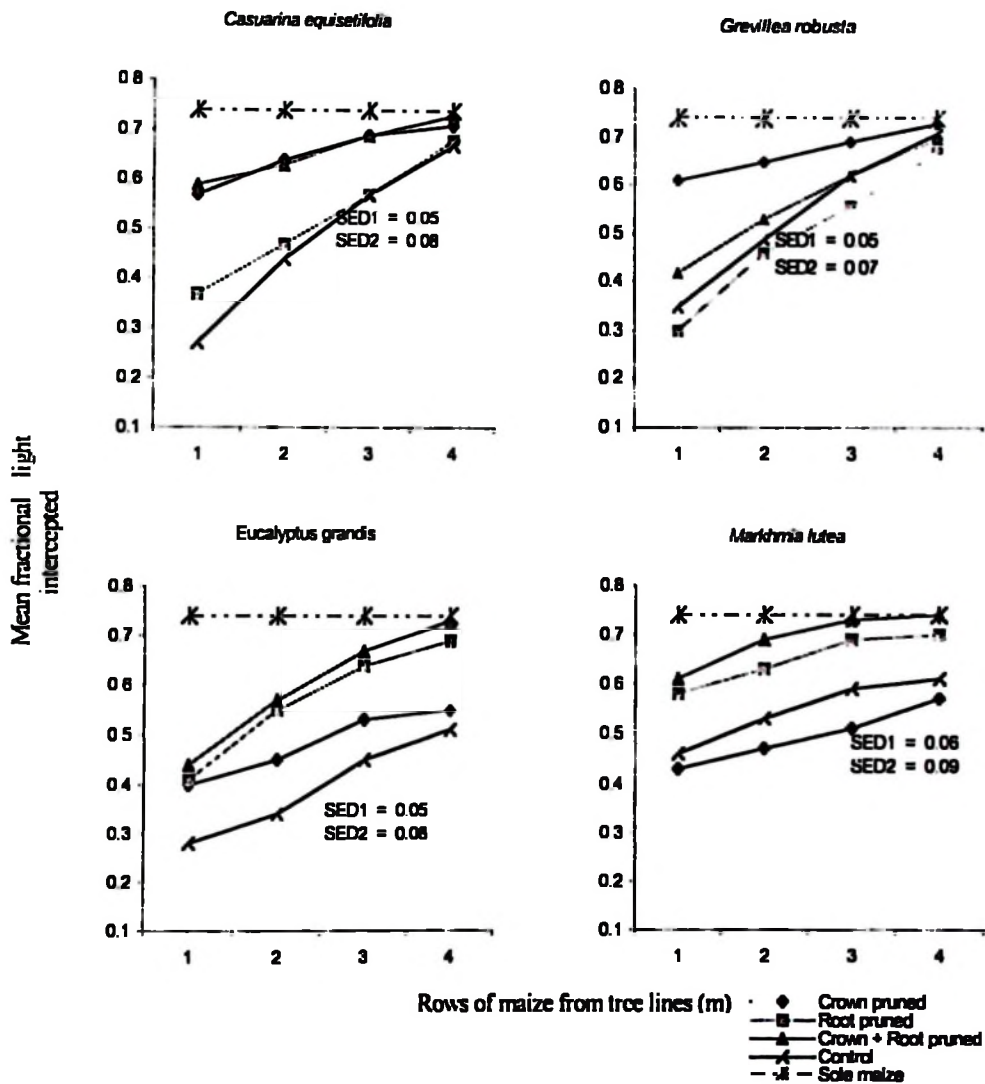

SED1 and SED2 as defined in Figure 4.5.2.

Figure 4.5.5: Effects of tree pruning on the mean PAR fractional interception by maize foliage (average of 4 measurements) for October-November 2000 at Siaya, western Kenya.

4.6.1 Siaya

4.6.1.1 Effect of tree pruning and distance from the tree line on maize growth

Maize height and root collar diameter during the first season following tree pruning, was recorded at 3, 6, and 8 weeks after maize sowing. Maize plant and cobs numbers were also counted during harvesting in the first season only. The assessments of both maize growth and counting of maize were then terminated, since both maize growth parameters and counting of maize were not good indicators of yield production.

The results of the effect of species, pruning treatments and distance of maize rows from tree lines and their interactions on maize height and root collar diameter during the first maize cropping season after pruning, are presented in Tables 4.6.1 and 4.6.2. Tree species and pruning treatment and their interactions resulted in significantly ($P < 0.001$) different mean height and root collar diameter on all the assessment occasions. However, an increase in distance from the tree line had no effect on maize height and root diameter (Table 4.6.1).

During the third week assessment, maize height and root collar diameter (Table 4.6.2) were relatively high under crown pruned and crown plus root pruned trees of all species. In general, during these assessment occasions, maize growth under *E. grandis* crown and crown plus root pruned trees was superior compared to that of maize under other tree species. *Casuarina equisetifolia* ranked second in its effect on maize height and root collar diameter growths. For *G. robusta* and *M. lutea*, maize

mean height and root collar diameter under root pruned trees exhibited the highest growths, compared to the other pruning treatments, during the 6th and 8th weeks assessments. For all the tree species, maize growth under the unpruned (control) trees was the poorest during all assessment occasions. Sole maize showed less growth compared to maize under crown and crown plus root pruned trees of all species and on all assessment occasions except for unpruned (control) *M. lutea* trees (Table 4.6.2).

Table 4.6.1: Probability values for greater F-ratios for the effect of species, pruning treatments and rows of maize from tree lines and their interaction at 3, 6, and 8 weeks after maize planting for maize growths, plant and cob numbers during the first season long rain in 1999 at Siaya, western Kenya.

Source of variation	Weeks after maize planting					
	3	6	8	3	6	8
	Height			Diameter		
Species (S)	0.0052*	0.0001**	0.0001**	0.0001**	0.033*	0.0001**
Pruning (P)	0.0001**	0.0001**	0.0001**	0.0001**	0.0001**	0.0001**
Rows (R)	0.814	0.313	0.090	0.180	0.055	0.059
S x P	0.0001**	0.0001**	0.0001**	0.0001**	0.0001**	0.0001**
S x R	0.082	0.075	0.078	0.066	0.059	0.051
P x R	0.069	0.071	0.080	0.078	0.063	0.055
S x P x R	0.147	0.999	0.850	0.875	0.363	0.940

Source of variation	Plant number	Cobs number
Species (S)	0.041*	0.006*
Pruning (P)	0.000**	0.000**
Rows (R)	0.637	0.363
S x P	0.001**	0.000**
S x R	0.381	0.297
P x R	0.609	0.114
S x P x R	0.851	0.733

** = Significant at $p < 0.001$ and * = significant at $p < 0.05$

4.6.1.2 Effect of tree pruning and distance from tree line on maize plant numbers and yield

Maize plant and maize cob numbers during the first maize cropping season after pruning were significantly ($P < 0.001$) different for both tree species and pruning treatments (Tables 4.6.1 and 4.6.3). There were also significant interactions ($P < 0.001$) between species and pruning treatments on both number of maize plants and number of cobs during the first cropping season of long rain in 1999 (Tables 4.6.1 and 4.6.3). Crown and crown plus root pruned *C. equisetifolia* trees resulted in highest maize plant and cob numbers (Table 4.6.3) as compared to the other tree pruning treatments. However, the highest maize plant and cob numbers did not give the highest grain yields at the time of harvesting.

Since growths and number of maize plant were not good indicators of maize grain yield and grain yield is rather more important to farmers than maize plant number and growths, more emphasis was, hereafter, given to maize grain yield.

The effects of species and tree pruning treatments were significantly ($P < 0.001$) different for both maize cob and grain yields on all assessment occasions, while the effects of increasing rows of maize from tree lines were not significantly ($P > 0.05$) different. There was also significant ($P < 0.001$) interaction between species and pruning treatments on maize cobs and grain yields in all the cropping seasons (Table 4.6.4). However, no significant interactions were observed for species, pruning treatments and rows of maize from tree lines.

In general, maize grain yield was highest under *M. lutea* followed by sole maize crop. *Eucalyptus grandis* ranked third while *C. equisetifolia* ranked 4th followed by *G. robusta* (Tables 4.6.5 and 4.6.6). *Markhamia lutea* tree crown and crown plus root pruned tree plots produced the highest maize yield compared to the other tree pruning treatments, during the first three maize growing seasons but these effects declined during the fourth and fifth cropping seasons (Tables 4.6.5 and 4.6.6).

For *E. grandis*, crown and crown plus root pruned trees resulted in the highest maize cob and grain yields during both the first and the second maize growing seasons (Tables 4.6.5 and 4.6.6). Root pruning of *E. grandis* trees gave more maize yield during the third, fourth and fifth cropping seasons than the first two seasons (Tables 4.6.5 and 4.6.6).

For *C. equisetifolia*, maize cob and grain yields were higher under crown plus root pruned trees. However, maize yields under root pruned trees did not differ from that under unpruned (control) trees, both scored least maize cob and grain yields during all measurement occasions except for the second season (Tables 4.6.5 and 4.6.6). Interestingly, for *G. robusta*, root pruned trees resulted in the highest maize yield during all the cropping seasons, compared to the other tree pruning treatments (Tables 4.6.5 and 4.6.6).

Table 4.6.2: The effect of tree pruning on maize height and root collar diameter (cm) at 3, 6 and 8 weeks after planting during the long rain in 1999 at Siaya, western Kenya.

Category	Height (cm)			Root collar diameter (cm)		
	3	6	8	3	6	8
<i>C. equisetifolia</i>						
Crown pruning	41.37 ^a	74.34 ^a	112.23 ^a	1.16 ^a	1.29 ^b	1.20 ^a
Root pruning	37.57 ^b	61.78 ^b	85.45 ^c	0.82 ^c	1.05 ^c	0.95 ^c
Crown & root pruning	40.01 ^a	72.88 ^a	103.72 ^b	1.12 ^b	1.34 ^a	1.13 ^b
Control (no pruning)	34.47 ^c	54.93 ^c	71.66 ^d	0.81 ^c	0.95 ^d	0.93 ^c
Prob > F-ratio	0.031	0.001	0.0001	0.001	0.031	0.000
SED	0.43	0.87	1.74	0.02	0.02	0.013
Lsd	0.83	1.58	3.17	0.03	0.03	0.02
<i>E. grandis</i>						
Crown pruning	46.00 ^a	92.13 ^a	149.61 ^a	1.32 ^a	1.38 ^a	1.29 ^a
Root pruning	38.29 ^b	68.68 ^b	102.98 ^b	1.02 ^c	1.18 ^c	1.12 ^c
Crown & root pruning	36.25 ^c	67.76 ^b	104.98 ^b	1.10 ^b	1.29 ^b	1.15 ^b
Control (no pruning)	29.66 ^d	51.98 ^c	62.48 ^c	0.77 ^d	0.92 ^d	0.90 ^d
Prob > F-ratio	0.0001	0.001	0.0001	0.0001	0.0001	0.0001
SED	0.50	1.09	2.27	0.02	0.012	0.01
Lsd	0.85	1.76	3.56	0.03	0.03	0.02
<i>G. robusta</i>						
Crown pruning	36.82 ^b	68.30 ^a	97.60 ^b	0.99 ^b	1.21 ^a	1.08 ^a
Root pruning	36.25 ^b	69.98 ^a	108.78 ^a	1.01 ^{ab}	1.24 ^a	1.10 ^a
Crown & root pruning	39.84 ^a	62.22 ^b	84.59 ^c	1.03 ^a	1.12 ^b	1.04 ^b
Control (no pruning)	34.68 ^c	60.44 ^c	79.58 ^d	0.82 ^d	1.04 ^c	0.96 ^c
Prob > F-ratio	0.005	0.003	0.000	0.009	0.032	0.021
SED	0.39	0.79	1.78	0.01	0.12	1.02
Lsd	0.80	1.55	3.42	0.02	0.02	0.02
<i>M. lutea</i>						
Crown pruning	41.45 ^a	66.18 ^a	99.12 ^b	1.23 ^a	1.33 ^a	1.15 ^a
Root pruning	36.78 ^b	66.43 ^a	105.88 ^a	1.02 ^c	1.18 ^b	1.10 ^b
Crown & root pruning	37.80 ^b	61.00 ^b	88.91 ^c	1.09 ^b	1.20 ^b	1.07 ^c
Control (no pruning)	31.49 ^c	49.84 ^c	64.61 ^d	0.91 ^d	1.03 ^c	0.91 ^d
Prob > F-ratio	0.011	0.002	0.0001	0.0001	0.001	0.0001
SED	0.42	0.86	2.06	0.012	0.013	0.01
Lsd	0.77	1.60	3.88	0.02	0.02	0.02
Sole maize	37.85	67.79	107.06	1.08	1.27	1.15

Values in the same column followed by different letters under each species category are significantly different ($P < 0.05$). SED is the standard error of the difference of means, Lsd = Least significant difference.

Table 4.6.3: Effects of tree species and pruning treatments on maize plant and cob numbers during the long rains of 1999 at Siaya, western Kenya.

Category	Number of plants/ha	Number of cobs/ha
<i>C. equisetifolia</i>		
Crown pruning	40772 ^a	29704 ^a
Root pruning	37144 ^b	20060 ^b
Crown & root pruning	35536 ^c	28928 ^a
Control (no pruning)	33272 ^d	16468 ^b
Prob > F-ratio	0.001	0.000
SED	688	1068
Lsd	1153.96	1625.32
<i>E. grandis</i>		
Crown pruning	37500 ^{ab}	34284 ^a
Root pruning	36888 ^b	30476 ^b
Crown & root pruning	38392 ^a	30476 ^b
Control (no pruning)	34464 ^c	18628 ^c
Prob > F-ratio	0.006	0.000
SED	620	1292
Lsd	1200.08	1996.8
<i>G. robusta</i>		
Crown pruning	35296 ^b	24880 ^b
Root pruning	37916 ^a	29880 ^a
Crown & root pruning	33808 ^c	25236 ^b
Control (no pruning)	36012 ^b	27616 ^a
Prob > F-ratio	0.000	0.000
SED	632	1172
Lsd	1232.24	2344.56
<i>M. lutea</i>		
Crown pruning	33156 ^c	22320 ^b
Root pruning	39704 ^a	32736 ^a
Crown & root pruning	35236 ^b	24164 ^b
Control (no pruning)	29644 ^d	15532 ^c
Prob > F-ratio	0.000	0.000
SED	236	1404
Lsd	402.57	2236.8
Sole maize control	35000	26428

For each species, values in the same column followed by different letters are significantly different ($P < 0.05$). SED is the standard error of the difference of means, Lsd = Least significant difference

Relative changes (%) in maize grain yield from various pruning treatments as compared to the sole maize plot are shown in Figure 4.6.1. In general, there was 50-80 % gain in maize yield under crown and root pruning as compared to those unpruned (control) trees. Crown and crown plus root pruning treatments also increased maize yield by 10-50% during the first two maize growing seasons as compared to the maize alone plots (Figure 4.6.2).

Table 4.6.4: Probability for greater F-ratio values for effect of species, pruning treatments and distance of maize rows from tree lines and their interactions on maize yield over the different cropping seasons at Siaya, western Kenya.

Cobs dry weight					
Source of variation	LR- 1999	SR- 1999	LR- 2000	SR- 2000	LR- 2001
Species (S)	0.006*	0.003*	0.051	0.0001**	0.0001**
Pruning (P)	0.0001**	0.0001**	0.0001**	0.0001**	0.010*
Rows (R)	0.090	0.782	0.248	0.077	0.064
S x P	0.0001**	0.000**	0.001**	0.0001**	0.0001**
S x R	0.846	0.749	0.981	0.938	0.752
P x R	0.062	0.399	0.987	0.993	0.469
S x P x R	1.000	0.999	0.999	1.000	0.960
Grain dry weight					
Species (S)	0.008*	0.004*	0.027*	0.003*	0.0001**
Pruning (P)	0.0001**	0.0001**	0.0001**	0.0001**	0.010*
Rows (R)	0.088	0.749	0.258	0.063	0.061
S x P	0.0001**	0.0001**	0.0001**	0.0001**	0.0001**
S x R	0.869	0.698	0.982	0.948	0.764
P x R	0.780	0.349	0.992	0.994	0.472
S x P x R	1.000	0.997	0.999	1.000	0.962

LR=Long rains, SR=Short rains, **=Significant at $p < 0.001$ and *=significant at $p < 0.05$

For each tree species, the effect of pruning treatments and distance from tree lines on maize grain yield were significantly ($P < 0.05$) different on all assessment occasions (Figures 4.6.2 and 4.6.3). When maize above ground biomass (cobs and stover dry

weights added) produced under pruned trees were also examined row by row, rows closer to the pruned trees produced more biomass during the first season, compared to rows that were away from the tree lines, except for the unpruned (control) plot (Figure 4.6.3).

4.6.2 Influence of root pruning and distance from the tree line on maize yield at Nyabeda

Tree pruning and increasing distance from tree line significantly ($P < 0.05$) influenced maize cob and grain yields during all assessment occasions, except for the 3rd and 4th seasons. However, their interaction had no significant effect throughout the study period (Table 4.6.7). During the first and second cropping seasons, maize grain yield was significantly highest in the sole maize plot. Maize grain yields from one-side root pruned and the other side unpruned tree plots were not significantly ($P > 0.05$) different. During the third cropping season, all treatment effects were no longer significant (Table 4.6.8).

Grain yield increased with distance from the tree lines of all pruned trees (Figure 4.6.4) with higher maize grain yield increase under one-side pruned trees compared to the other side unpruned and both side unpruned (control) trees. No significant differences were observed on the effect of increasing distance from the tree line on maize grain yields under the other side unpruned and unpruned (control) plots. Maize grain yield under all the tree pruning treatments were the same during the short rain in 2000 planting season.

Table 4.6.5: Effects of tree pruning treatments on dry maize cobs yield (kg/ha) over five cropping seasons at Siaya, western Kenya.

Treatments	Cropping seasons				
	Long rain 1999	Short rain 1999	Long rain 2000	Short rain 2000	Long rain 2001
<i>C. equisetifolia</i>					
Crown pruning	770.6 ^b	2578.68 ^a	437.72 ^b	468.36 ^b	738.84 ^b
Root pruning	211.24 ^c	1045.92 ^c	76.08 ^c	252.841 ^c	287.36 ^c
Crown + Root	887.16 ^a	2554.52 ^a	760.24 ^a	708.32 ^a	866.68 ^a
Control	255 ^c	1546.84 ^b	121.96 ^c	312.32 ^c	349.64 ^c
Lsd	70.52	159.88	74.44	68.12	66.8
Sole maize ³	781.2	2263.4	1494.56	944.08	1036.84
<i>E. grandis</i>					
Crown pruning	1547.8 ^a	2699.8 ^a	419.04 ^c	573.84 ^b	874.6 ^b
Root pruning	732.92 ^c	2121.08 ^b	783.48 ^a	670.8 ^a	1119.76 ^a
Crown + Root	1010.6 ^b	2338.72 ^b	535.96 ^b	559.68 ^b	799.48 ^c
Control	166.52 ^d	898.08 ^c	158.4 ^d	393.36 ^c	924.24 ^b
Lsd	154.72	212	100.44	93.96	74
Sole maize	781.2	2263.4	1494.56	944.08	1036.84
<i>G. robusta</i>					
Crown pruning	602.64 ^b	1788.32 ^b	539.88 ^b	502.8 ^b	727.84 ^b
Root pruning	982.08 ^a	1702.2 ^b	327.24 ^c	301.92 ^c	683.36 ^b
Crown + Root	621.52 ^b	2361.88 ^a	719.76 ^a	906.12 ^a	911.28 ^a
Control	360.76 ^c	1397.88 ^c	240.08 ^d	298.8 ^c	608.16 ^c
Lsd	101.8	154.96	73.04	55.32	82.16
Sole maize	781.2	2263.4	1494.56	944.08	1036.84
<i>M. lutea</i>					
Crown pruning	990.84 ^a	2657.8 ^a	707.84 ^a	590.32 ^b	845.76 ^b
Root pruning	841.08 ^a	1931.36 ^b	506.56 ^b	598.8 ^b	1040.28 ^a
Crown + Root	553.72 ^b	2725.24 ^a	643.92 ^a	602.24 ^b	1016.8 ^a
Control	226 ^c	1874.04 ^b	298.12 ^c	804.8 ^a	895.24 ^b
Lsd	168.08	168	101.8	76.16	105.2
Sole maize	781.2	2263.4	1494.56	944.08	1036.84

For each species, values in the same column followed by different letters are significantly different ($P < 0.05$). Lsd = Least significant difference.

³ In all the analysis under taken the sole maize plot was seen as an added control and it was used as a contrast in comparing its significant levels with species, treatments and distance of maize from the tree lines.

Table 4.6.6: Effects of tree pruning treatments on dry maize grain yield (kg/ha) over five cropping seasons at Siaya, western Kenya.

Treatments	Cropping seasons				
	Long rain 1999	Short rain 1999	Long rain 2000	Short rain 2000	Long rain 2001
<i>C. equisetifolia</i>					
Crown pruning	626.08 ^b	2158.96 ^a	355.76 ^b	380.16 ^b	620 ^b
Root pruning	175.4 ^c	947.88 ^c	61.44 ^c	203.84 ^c	243.92 ^c
Crown + Root	730.44 ^a	2099.92 ^a	622.4 ^a	598.16 ^a	714.28 ^a
Control	192.32 ^c	1303.6 ^b	50.24 ^c	255.84 ^c	281.6 ^c
Lsd	58.48	142.16	60.64	56.6	56.8
Sole maize	638.72	1804.08	1219.4	784.96	884.04
<i>E. grandis</i>					
Crown pruning	1300.28 ^a	2264.76 ^a	347.28 ^b	471.8 ^a	732.16 ^{bc}
Root pruning	596.8 ^c	1762.56 ^c	644.92 ^a	546.8 ^{ab}	936.24 ^a
Crown + Root	794.6 ^b	1950.2 ^b	383.64 ^b	465.44 ^b	676.48 ^c
Control	131.2 ^d	743.84 ^d	126.04 ^c	321.2 ^c	789.08 ^b
Lsd	133.52	174.68	87.6	79.48	62.56
Sole maize	638.72	1804.08	1219.4	784.96	884.04
<i>G. robusta</i>					
Crown pruning	487.28 ^b	1311.16 ^b	450.16 ^b	411.28 ^b	625.76 ^b
Root pruning	808.36 ^a	1429.96 ^b	268.44 ^c	249.72 ^c	574.48 ^c
Crown + Root	516.48 ^b	2032.28 ^a	607.32 ^a	760.32 ^a	762.72 ^a
Control	291.92 ^c	1165.88 ^c	191.12 ^d	234.88 ^c	518.28 ^c
Lsd	83.96	128.92	61.2	46.12	69.2
Sole maize	638.72	1804.08	1219.4	784.96	884.04
<i>M. lutea</i>					
Crown pruning	817.12 ^a	2282.08 ^a	595.52 ^a	488.48 ^b	722.88 ^b
Root pruning	696.72 ^b	1609.24 ^b	418.08 ^b	490.4 ^b	873.96 ^a
Crown + Root	456.6 ^c	2264.08 ^a	532.64 ^a	482.6 ^b	878.4 ^a
Control	166.88 ^d	1566.56 ^b	249.84 ^c	655.2 ^a	758.12 ^b
Lsd	141	140.2	84.16	62.96	89.76
Sole maize	638.72	1804.08	1219.4	784.96	884.04

For each species, values in the same column followed by different letters are significantly different ($P < 0.05$). Lsd = Least significant difference.

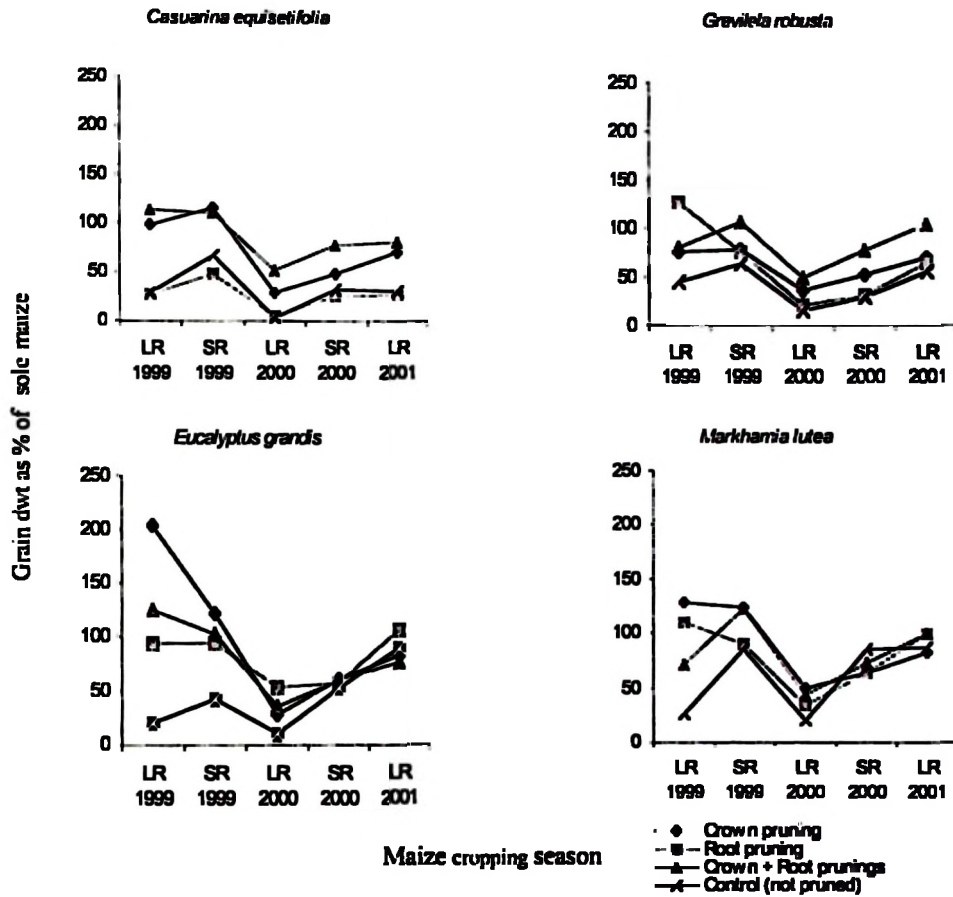

LR = long rains, SR = short rains⁴

Figure 4.6.1: Effect of tree pruning treatments on relative maize yield at Siaya, western Kenya.

⁴ Rainfall received during the 3rd maize cropping season (2000) was much less than the other cropping seasons and probably the reason why low yield was recorded in that year than the following year (2001).

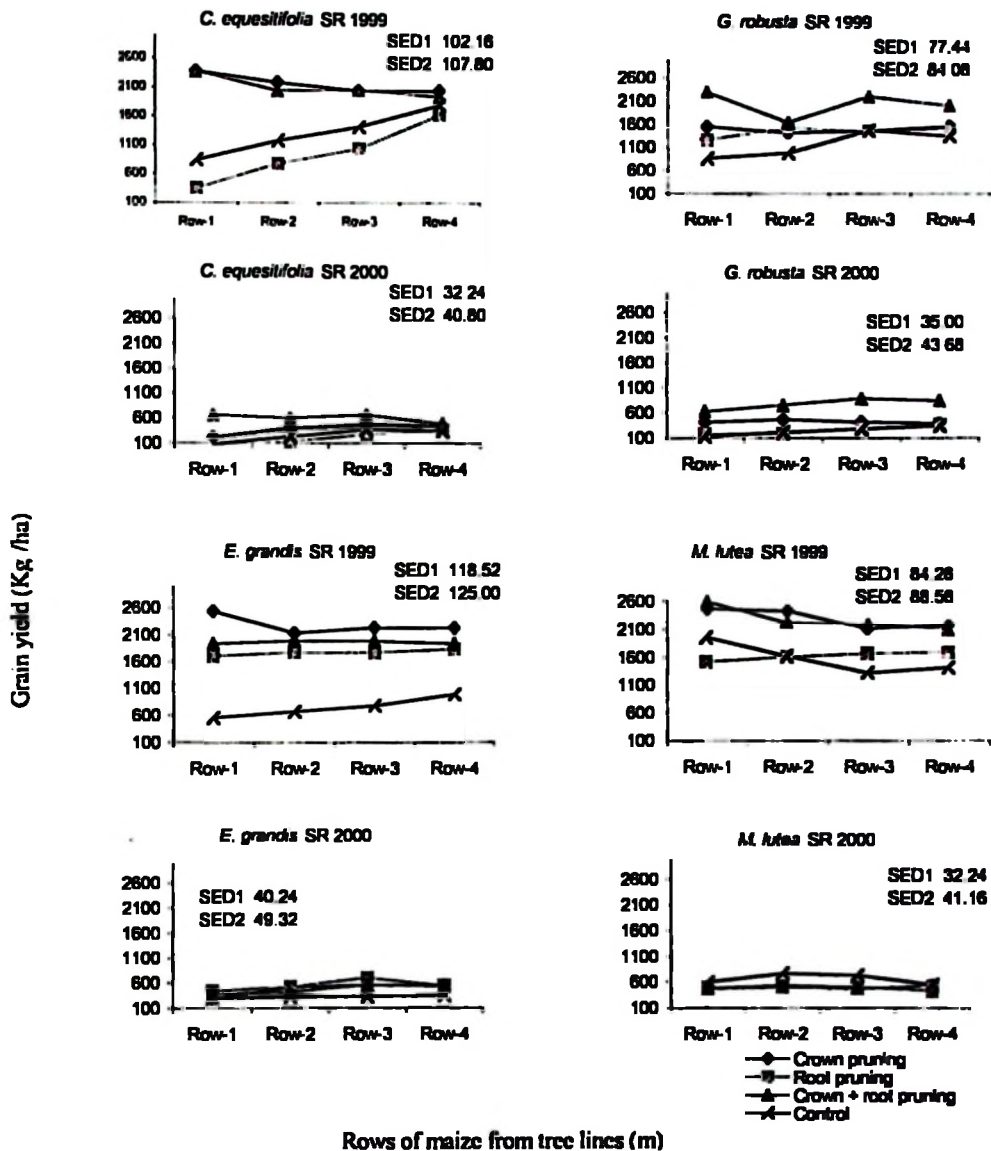

SED1 = Standard error of the difference between rows in a treatment, SED2 = Standard error of the difference between pruning treatments in a given row.

Figure 4.6.2: The effect of increasing distance from pruned trees on maize grain yield during the short rains maize cropping season of 1999 and 2000 at Siaya, western Kenya.

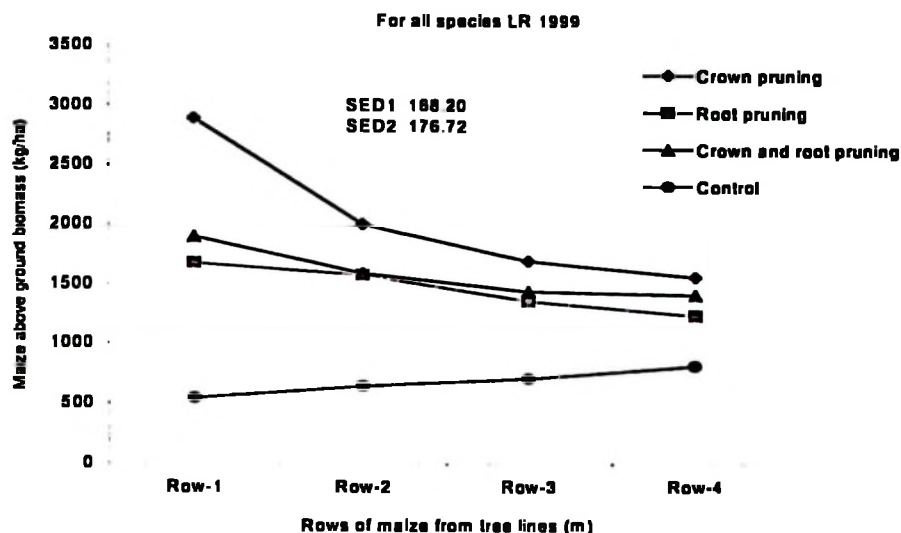

SED1 = Standard error of the difference (SED) between rows in a treatment. SED2 = Standard error of the difference (SED) between treatments in a given row.

Figure 4.6.3: Effect of increasing distance from the line of pruned trees on the maize above ground biomass at Siaya, western Kenya.

Table 4.6.7: Probability for greater F-ratio values of the effect of root pruning and increasing distance of maize rows from pruned tree lines and their interactions on maize cobs dry weight (kg/ha) and maize grain yield (kg/ha) during different cropping seasons at Nyabeda, western Kenya.

Cobs dry weight				
Source of variation	SR-1999	LR-2000	SR-2000	LR-2001
Pruning (P)	0.0001*	0.006*	0.839	0.003*
Rows (R)	0.007*	0.0001**	0.002*	0.252
P x R	0.679	0.835	0.999	0.993
Grain yield				
Pruning (P)	0.002*	0.004*	0.632	0.005*
Rows (R)	0.0001**	0.0001**	0.0001**	0.383
P x R	0.728	0.840	0.999	0.861

** = significant at $p < 0.001$ and * = significant at $p < 0.05$

During the fourth cropping season of the long rain in 2001, maize grain yield was higher⁵ under the unpruned (control) trees and the other side unpruned tree plots than the sole maize plots and the one side root pruned tree plots. However, lowest maize grain yield was recorded in the sole maize plots when compared to all other plots under trees, with or without root pruning. Statistically, maize grain yields under one side root pruned trees and the sole maize were the same while the other side-unpruned plot was the same as the both sides unpruned (control) tree plots (Table 4.6.8).

Table 4.6.8: Effect of tree root pruning on maize grain yield during the four cropping seasons at Nyabeda, western Kenya.

Treatments	Cropping seasons			
	Short rain 1999	Long rain 2000	Short rain 2000	Long rain 2001
Cobs dry weight in kg / ha				
One side root pruned	476.04 ^b	924.6 ^b	591.92 ^a	682.28 ^b
The other side un-pruned	504.28 ^b	783.88 ^c	602.2 ^a	867.32 ^a
Both sides un-pruned control	353.84 ^c	743.12 ^c	621.24 ^a	909.6 ^a
Sole maize	674.68 ^a	1012.96 ^a	611.32 ^a	643.72 ^b
Lsd	58	62.76	59.08	56.48
Grain dry weight in kg / ha				
One side root pruned	566.52 ^b	743.88 ^b	479.6 ^a	549.8 ^b
The other side un-pruned	512 ^b	652.2 ^c	493.32 ^a	684.2 ^a
Both sides un-pruned control	391.32 ^c	619.84 ^c	500.84 ^a	736.36 ^a
Sole maize	678.92 ^a	827.56 ^a	485.72 ^a	501.6 ^b
Lsd	58	52.08	48.2	52.8

For each species, values in the same column followed by different letters are significantly different ($P < 0.05$). Lsd = Least significant difference.

⁵ Rainfall received during the 3rd cropping season was much less than the other cropping seasons and probably the reason why differences between pruning treatments for grain yield were observed during all the other cropping seasons but not during the 3rd cropping season of 2000.

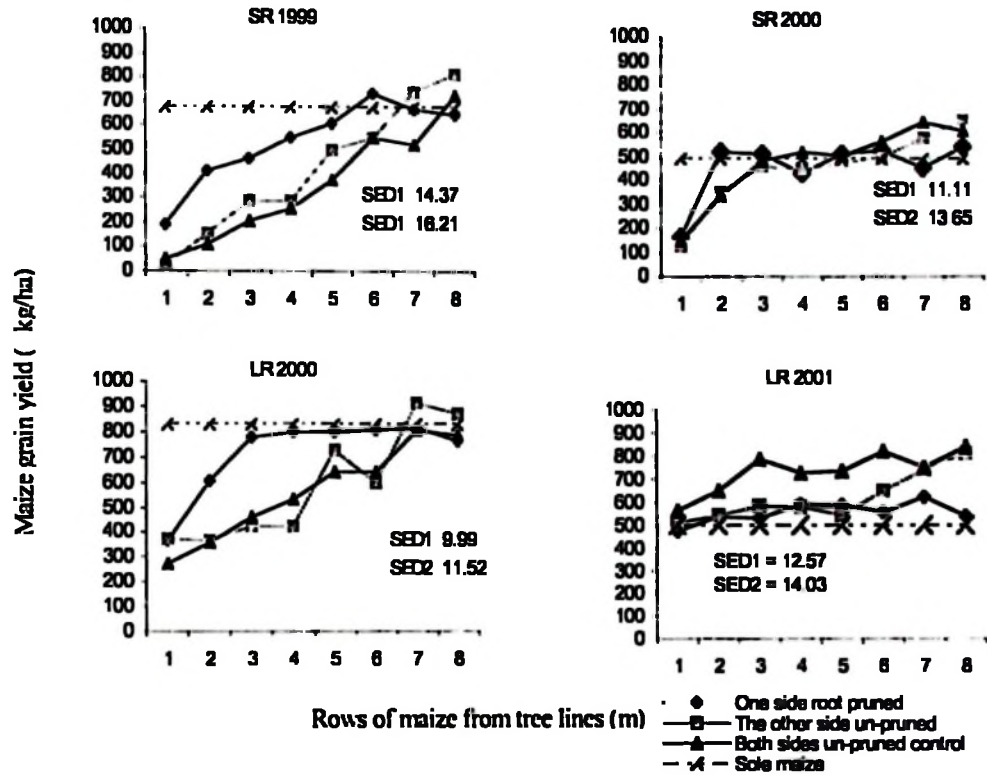

SED1 = Standard error of the difference (SED) between rows in a treatment.
 SED2 = Standard error of the difference (SED) between treatments in a given row.

Figure 4.6.4: Effect of increasing distance from tree line subjected to root pruning treatments on mean maize grain yield at Nyabeda, western Kenya.

4.7 Trends and relationships between rainfall, percent volumetric soil water content (VSWC), sap flow, light and maize grain yield at Siaya

This section summarizes the trends and relationships that existed between the different parameters measured at Siaya experimental plots. This includes effects of the amount of rainfall received on %VSWC, and the effects of %VSWC, sapflow and PAR on maize yield under different pruning treatments applied to different tree species at Siaya.

4.7.1 Effects of Rainfall on %VSWC

The patterns of %VSWC content followed that of rainfall received in the area (Figure 4.7.1). Percent VSWC increased with an increase in rainfall received and vice versa when the rainfall received decreased.

4.7.2 Influence of %VSWC, sap flow and PAR on maize grain yield

Generally, 67% of maize grain yield under all species and pruning treatments was influenced by %VSWC while 40% was influenced by %PAR intercepted by maize canopy.

4.7.2.1 Influence of %VSWC on maize grain yield for of all distances and depths of soil during the 1st (long rain 1999) and 2nd (short rain 1999) maize growing seasons at Siaya.

As noted earlier, the amount of rainfall received in the area influenced the %VSWC (Figure 4.7.1). An increase in rainfall increased %VSWC, however with significant ($P < 0.05$) variability when soil water was monitored under the different tree pruning treatments during early stage after tree pruning (Figure 4.7.1). This resulted in significant variability amongst the maize grain yields produced under the different treatment plots, where pruned plots had more %VSWC and hence higher maize grain yield, while the un pruned control plots had lower maize grain yield production in most cases (Figure 4.7.2).

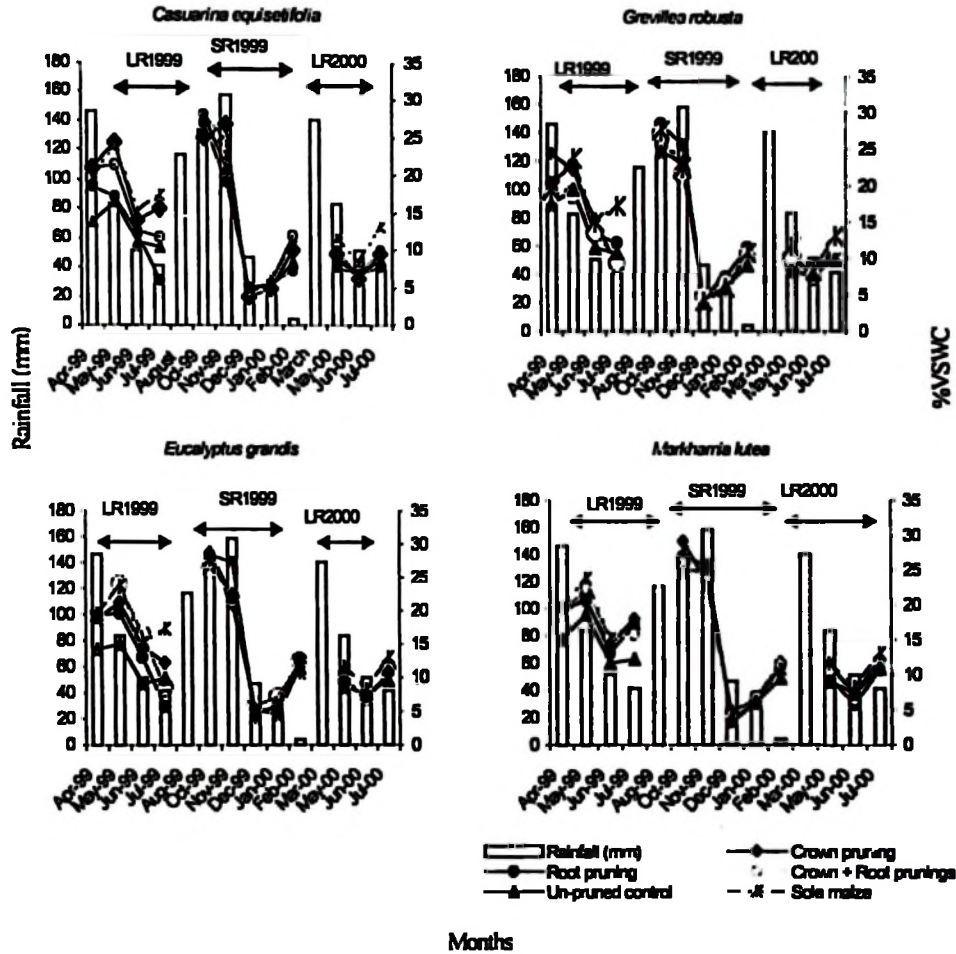

Figure 4.7.1: Effects of mean rainfall received on mean %VSWC of all sampled distances from tree lines and soil depths over three maize cropping seasons (1st season long rain 1999, 2nd season short rain 1999 and 3rd season long rain 2000) at Siaya, western Kenya.

There was a strong positive ($P < 0.01$) relationships between %VSWC and maize grain yield (kg/ha) for *C. equisetifolia* ($R^2 = 0.82$) and *M. lutea* ($R^2 = 0.66$). No significant correlation ($P > 0.05$) between %VSWC and maize yield for other tree species. The correlation of these two parameters was also influenced by tree pruning treatments (Figure 4.7.3).

4.7.2.2 Relationships between maize grain yield and sap flow of *C. equisetifolia* and *G. robusta* trees during the 3rd (long rain 2000) - 4th (short rain 2000) maize growing seasons at Siaya, western Kenya

The result of the relationship between maize grain yield and sap flow of *C. equisetifolia* and *G. robusta* (Figure 4.7.4) show that they were moderately but negatively correlated ($P < 0.05$).

4.7.2.3 The relationship between PAR intercepted by maize and maize grain yield under four boundary tree species during the 1st (long rain 1999) and 4th (short rain 2000) maize growing seasons at Siaya, western Kenya.

Maize grain yield was positively influenced by PAR under *C. equisetifolia* during both the first ($R^2 = 0.84$) and 4th ($R^2 = 0.81$) seasons of maize planting, while that under Eucalypts was influenced by PAR only during the first cropping season ($R^2 = 0.97$). Under other study species it was not influenced by PAR (Figures 4.7.5 and 4.7.6).

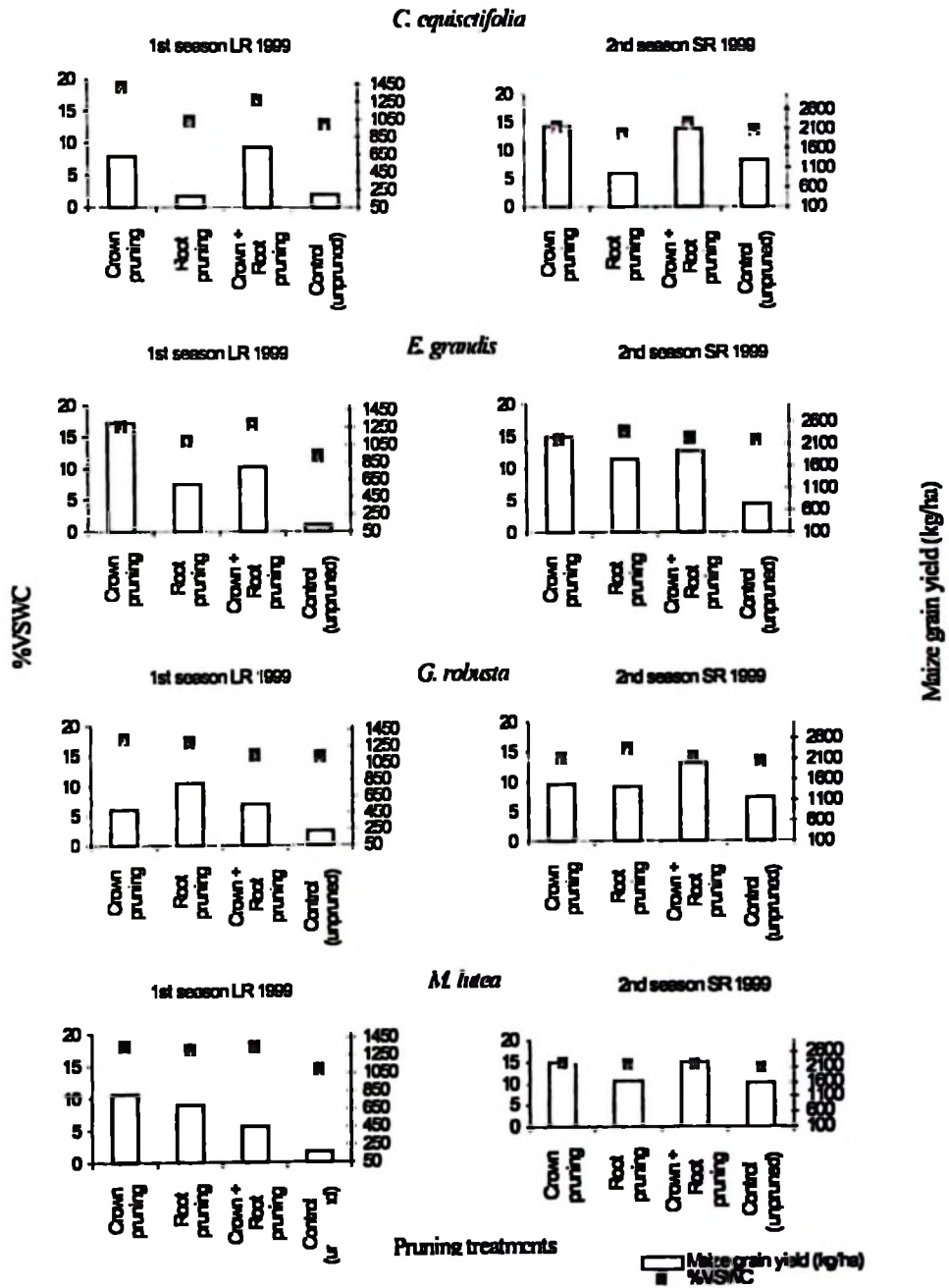

Figure 4.7.2: Effects of mean %VSWC of all sampled distances from tree lines and soil depths on maize grain yield produced the 1st and 2nd maize cropping seasons of long rain 1999 and short rain 1999 at Siaya, western Kenya.

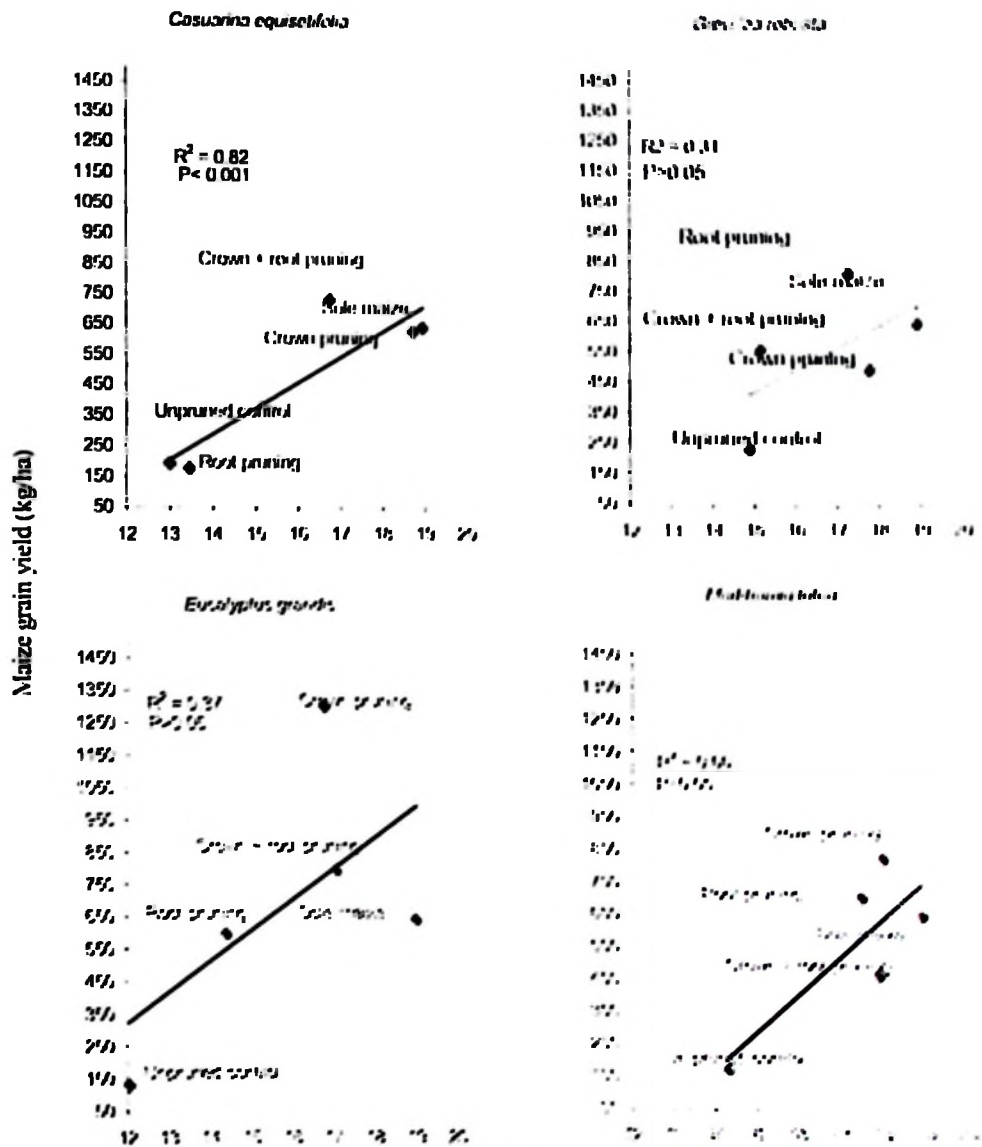

Figure 4.1.3: Relationships between maize grain yield and %WSSM during the (long rain 1999) and 2nd (short rain 2000) maize cropping seasons in Siaya, western Kenya.

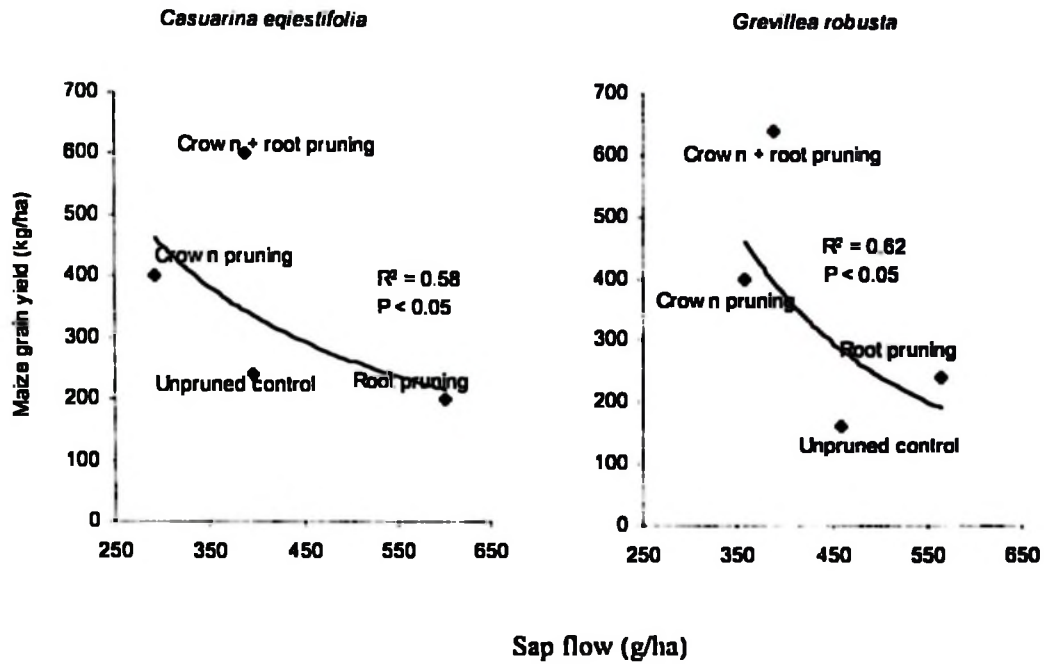

Figure 4.7.4: Mean relationships between maize grain yield and sap flow of *C. equisetifolia* (a) and *G. robusta* (b) during the 3rd (long rain 2000) & 4th (short rain 2000) maize cropping seasons at Siaya, western Kenya.

4.7.3 The relationship between sap flow of *C. equisetifolia* and *G. robusta* trees subjected to different pruning treatments and %VSWC and PAR at Siaya, western Kenya

4.7.3.1 The relationship between sap flow of *C. equisetifolia* and *G. robusta* trees and %VSWC during the 3rd & 4th maize growing seasons of the long-shot-rains of 2000 at Siaya, western Kenya

An increase in %VSWC increased sap flow but was significantly influenced by tree's crown pruning (Figure 4.7.7). Crown pruned trees significantly transpired less than the unpruned (control) plots or root only pruned plots.

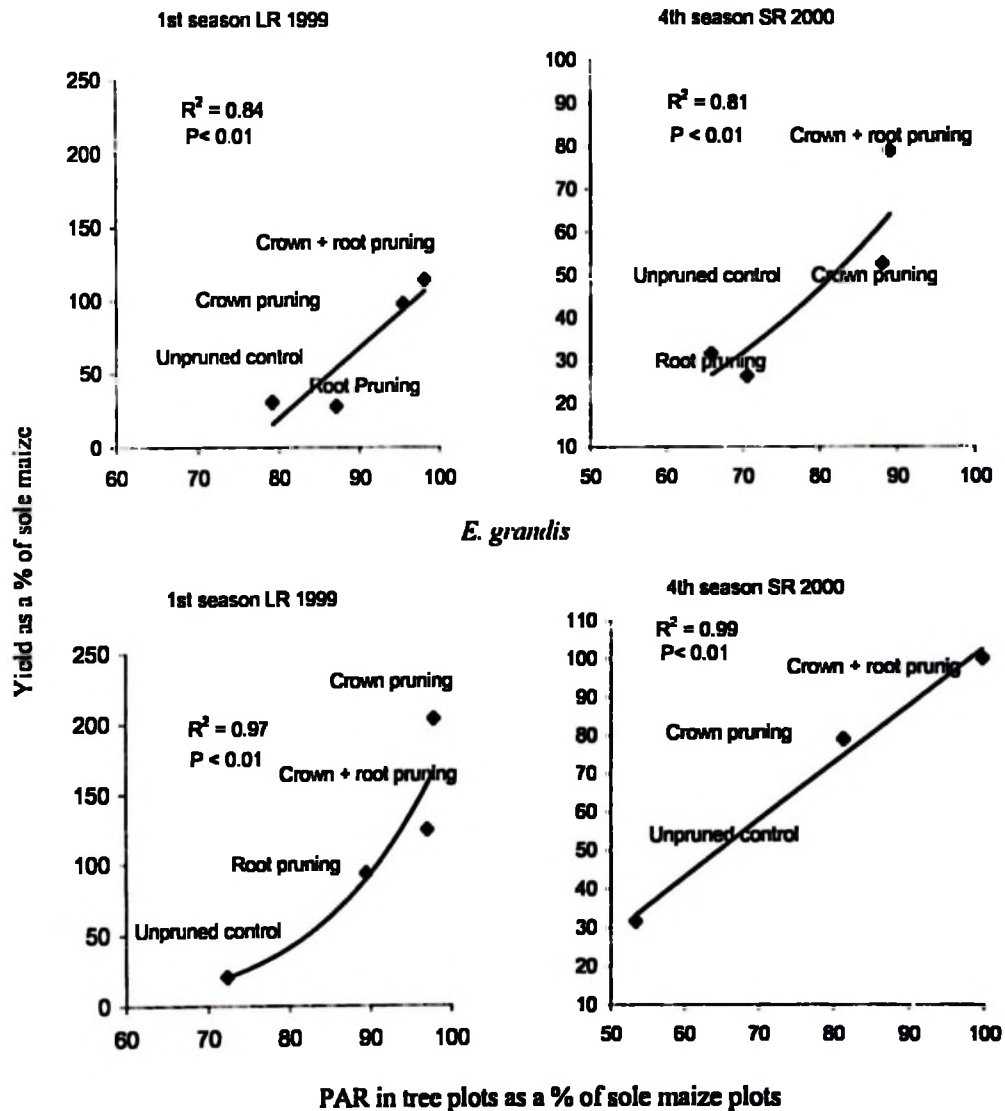

Figure 4.7.5: Mean relationships between maize grain yield and PAR under 4 boundary planted trees during the 1st (long rain 1999) and the 4th (short rain 2000) maize cropping seasons at Siaya, western Kenya.

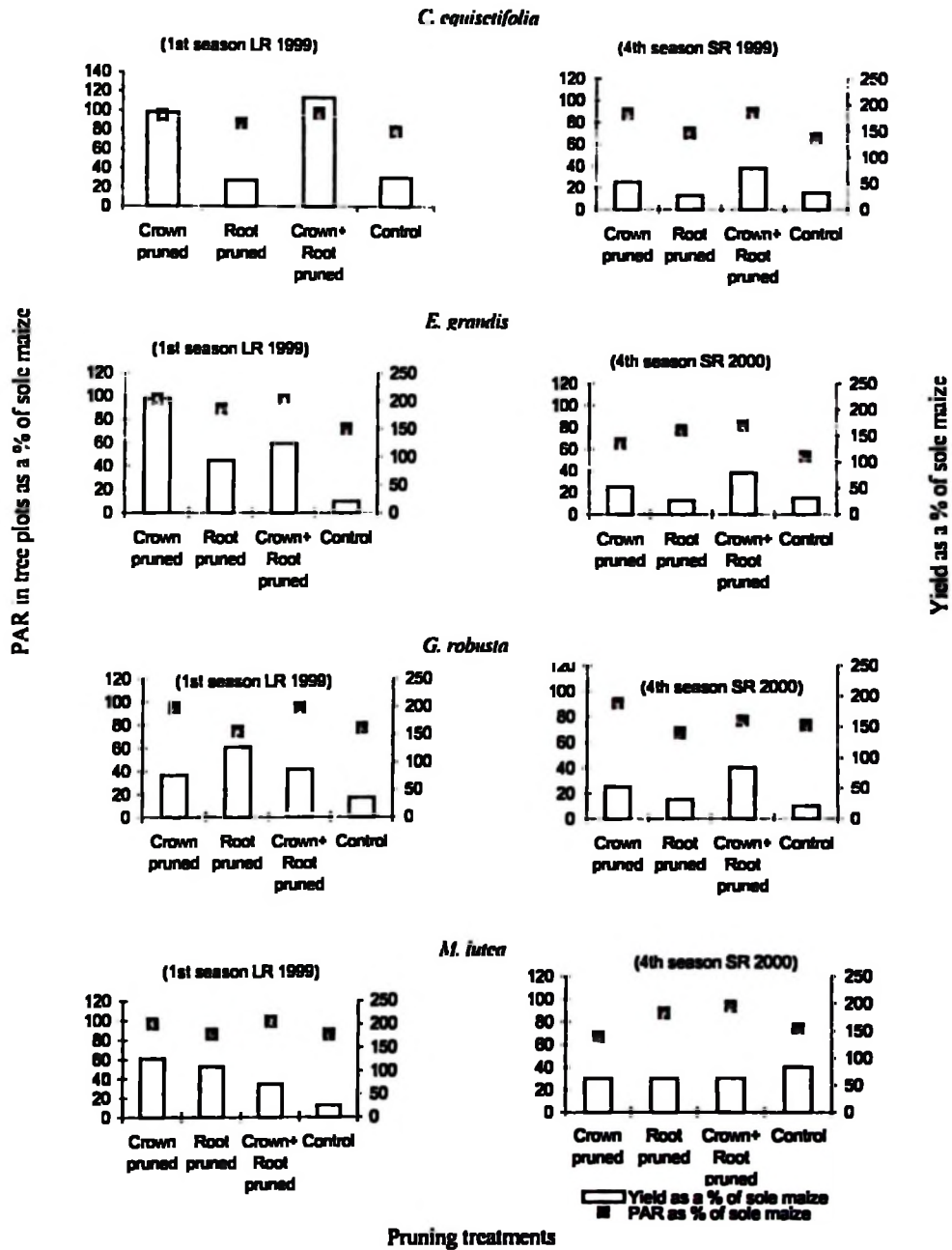

Figure 4.7.6: Trends for PAR as % of sole maize and maize yield as a % of sole maize plots during the 1st (long rain 1999) and 2nd (short rain 1999) seasons of maize planting at Siaya, western Kenya.

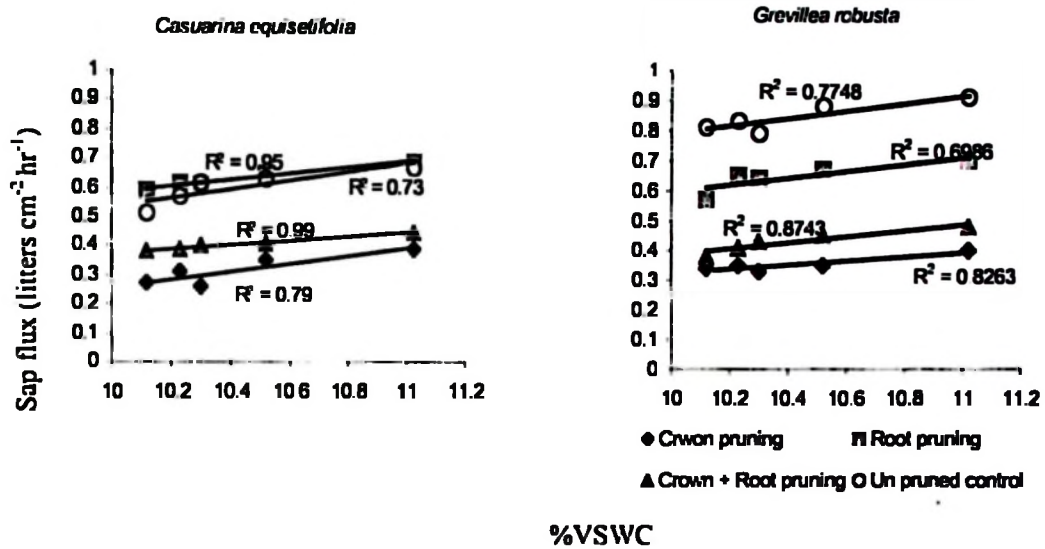

Figure 4.7.7: Relationships between %VSWC and Sap flow for all distance from the tree line and soil depths for *C. equisetifolia* and *G. robusta* subjected to different pruning treatments during the 3rd & 4th season of long rain 2000 at Siaya, western Kenya.

4.7.3.2 The relationship between sap flow of *C. equisetifolia* and *G. robusta* trees and tree light interception during the 3rd & 4th maize growing seasons of the long-shot-rains of 2000 at Siaya, western Kenya

The amount of sap flow was positively influenced by the amount of light intercepted by *C. equisetifolia* and *G. robusta* trees (Figure 4.7.8).

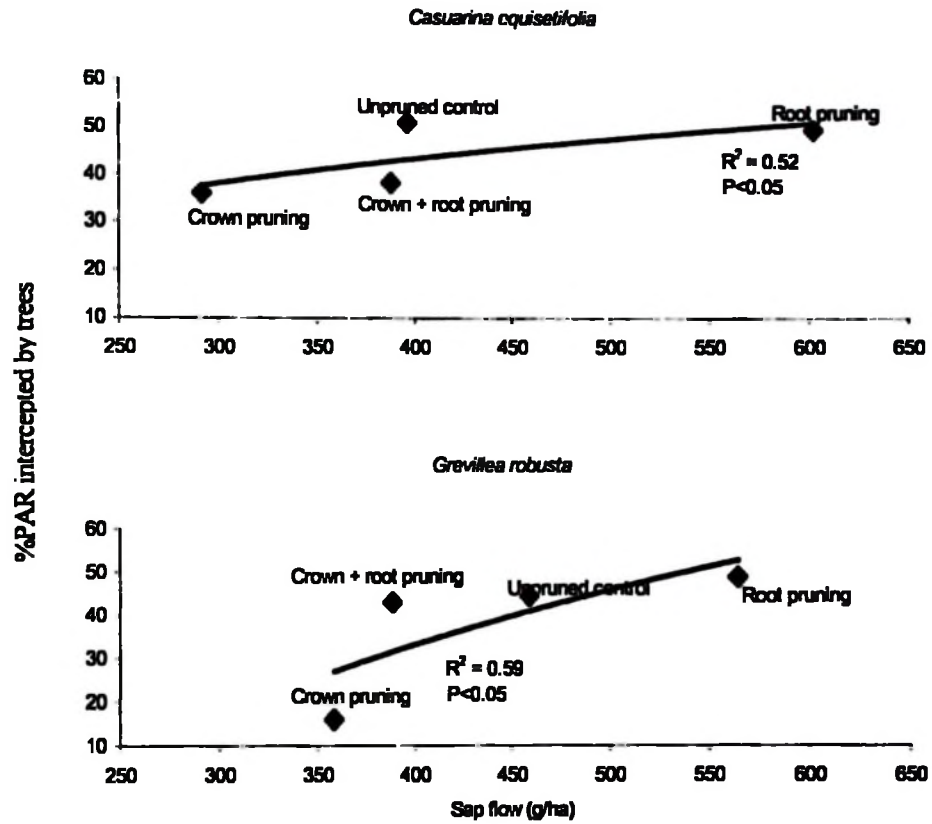

Figure 4.7.8: The mean relationships between PAR interception and sap flow under *C. equisetifolia* and *G. robusta* boundary trees during the 4th maize cropping season at Siaya, western Kenya.

CHAPTER FIVE

5.0 DISCUSSION

5.1 General

This chapter is a synthesis of the results presented in chapter 4. Section 5.2 discusses the main findings of the farmers' survey results in Siaya while Sections 5.3 through 5.7 discusses the field experimental findings on tree-crop interactions, mainly for below and above ground resources, at both Siaya and Nyabeda sites. However, the comparisons of the results of this study are limited due to lack of similar earlier studies. This is because heavy crown and root pruning of commercially valuable big tress in boundary planting is a new research area.

It is not possible to totally avoid competition of trees with crops for growth resources because of temporal and spatial overlaps in their use of resources. The way out is to focus on the interventions in which trees are purposely managed for increased production of both trees and crops.

Knowledge of tree management to control competition may enable farmers to include commercially valuable tree species on their farms. Therefore, a survey was undertaken to determine what farmers did know about tree-crop competition. The field experiments were conducted in order to determine how effectively crown and root prunings of four tree species could reduce competition between trees with crops

for water. This was achieved by soil, tree and crop responses after tree pruning. Crop water use was not monitored directly, but was inferred from crop growth and yield.

5.2 Farmers' survey, farmers and pole/timber merchants evaluations of boundary planting tree species at Siaya site

5.2.1 Farmers' Survey

Most of the decision makers between the age classes of 41-50 seem to live outside the farm, probably working in towns so that they can earn additional household income. At age of 51-60 they probably have retired from work places and settled at their home, and therefore, this age class was frequently observed. Similar results have been reported elsewhere (Sanchez, 1995; Swinkeles; Mugo, 1998; Tefera *et al.*, 2001).

Farmers in Siaya grow trees mainly for fuelwood, construction poles, timber, shade, boundary demarcation, fruits and cash generation. Rocheleau *et al.* (1988), Arnold and Nair (1991) and Dewees (1997) also reported variety of purposes for growing trees in the developing countries.

The main types of niches for trees on-farms identified in Siaya matched with earlier findings reported elsewhere (Von Madell, 1987; MacDicken, 1990; Wilson *et al.*, 1999; Tefera *et al.*, 2001). These were hedgerows in croplands, internal and external farm boundaries and homesteads.

All farmers who planted trees along agricultural fields observed adverse shading effects and tree root interference with crops but did very little to manage the problems as the knowledge gap in managing trees that are grown with crops was high in Siaya. The suppressive effect of boundary trees on annual crops reported by Siaya farmers has also been reported elsewhere in the tropics (Malik and Sharma, 1990; Puri and Bangarwa, 1992; Dhyani *et al.*, 1996; Tyndall, 1996; Wilson *et al.*, 1999).

During the survey, Siaya farmers expressed their interest in growing more trees in the future. Most of them, however, would do so if they could get support of tree seeds and/or seedlings for planting. Farmers also requested for support of pesticides and advise on tree management in order to reduce competition with crops. The main drawbacks of practicing boundary tree planting by farmers were also reported by Hoekstra *et al.* (1991), Akyeamponge *et al.* (1999) and Wilson, *et al.* (1999).

Tree crown and/or root pruning of commercially valuable trees species is not practiced in Siaya. Indigenous trees, such as *M. lutea*, are either side pruned or completely felled to enable stump coppicing. Embu district in central Kenya was chosen for comparison of farmers' tree pruning practices with Siaya. Because tree branch pruning or pollarding in Embu has been a common practice for decades (Tyndall, 1996) and, therefore, other districts in the country have a lot to learn from the Embu types of shoot (crown) pruning practice. However, root pruning has not been practiced by farmers in Embu or in other parts of the country.

Farmers in Embu District practice crown pruning or pollarding of *G. robusta* trees which are grown primarily for boundary demarcations and timber. Tree felling or complete harvesting of trees in Embu is not a common practice, as trees are needed to stand on boundaries. Tyndall (1996) reported that a Chief's permission is required to cut trees. Therefore farmers used tree pollarding as a substitute for tree felling. Most Embu farmers get their firewood from tree pruning rather than tree felling.

Tree pruning is more valued in Embu than in Siaya because of demands for fuelwood and quality timber. Thus, tree management practices such as tree pruning in Embu are more sophisticated, in types and magnitudes, than in Siaya. In Embu, pruning is undertaken to reduce shade, improve timber quality and obtain fuelwood. Branch pruning is practiced to encourage the development of a straight, knot-free trunk, while canopy pruning is practiced to enhance diameter increment.

Farmers in Siaya give little attention for timber quality. In Siaya, tree felling for coppicing by cutting at ground level is the main form of tree pruning. On the other hand, farmers in Embu depend on planted trees, especially on *G. robusta*, for household needs. Farmers in Siaya have relatively more access to natural forests and most of them can obtain wood from forests. However, there is a lesson to be learned from Embu by Siaya farmers, as the area under natural vegetation is already diminishing in Siaya.

Siaya farmers need to grow more diversified trees and learn from other districts, such as Embu, on how to prune trees and use for household needs while the remaining trunk on the ground can grow to a marketable size for timber and cash generation. Siaya farmers are aware of the problem of availability of wood for household need and the need for management practices on existing trees and the needs for planting more trees on their farms.

5.2.2 Farmers and pole/timber merchants evaluations of tree species at age 48 months i.e. just before pruning

The most preferred tree species based on familiarity, growth rate and value by both farmers and pole/timber merchants in Siaya was *M. lutea*, which is an indigenous tree species in the area. Although *M. lutea* performed poorly in both growth and stem form in this study it was the most preferred species in Siaya. This is may be because it was the most available tree species in the area. Poles, timber, charcoal, fuelwood, furniture, ornamental and intercropping were some of the products obtained from *M. lutea*.

The second most preferred species was *E. grandis* followed by *G. robusta* and *C. equisetifolia*. *Eucalyptus Grandis* was preferred for poles, fuelwood, timber and furniture. However, farmers would intercrop this species only if they could prune trees regularly, otherwise they would prefer to plant it as woodlots.

The biggest variation between farmers and pole/timber merchants, in evaluating tree species, was price estimates (see Chapter 4.2). This might be due to the fact that, farmers are tree sellers and pole/timber merchants are tree buyers. Thus, it is only natural that farmers would overestimate the price of trees while the pole/timber merchants would underestimate.

In order to get some compromises, one can average the two price estimates and/or to get market price values for each tree species in the area. Unfortunately, no timber market was available for the tree species that were under test and, therefore, it was not possible to make a comparison of the market price with the prices that were gathered from the farmers and the pole/timber merchants in this study.

5.3 Tree pruning and tree responses to crown and root prunings

5.3.1 Siaya

5.3.1.1 Biomass produced from crown pruning and time taken in tree crown and root prunings

Crown and root pruning treatments were applied to 4 years old commercially valuable tree species (*C. equisetifolia*, *E. grandis*, *G. robusta* and *M. lutea*) that were grown as boundary plantings at Siaya experimental site. Crown pruning of all the four tree species produced a large amount of woody biomass, which can be used as fire wood and construction materials.

The second pruning of all tree species which was done in just 5 months after the first pruning to reduce number of sprouts (4-5 coppice branches/tree) from the main stem for later selection produced woody materials, which can be used for firewood, and other domestic uses. *Eucalyptus grandis* was re-pruned 3-4 times/year (during the first year after the first pruning) as it was having branches all over its trunk and those pruned materials could also be used to supplement household wood needs.

The frequency of *E. grandis* pruning was reduced after a year and the selected 4-5 branches were left to grow. The result from the second pruning shows that trees of all species can produce a significant amount of fuelwood materials if trees were to be pruned every year or two. Farmers who visited the experiment said that they would prune their trees at 1-2 year intervals. Namirembe (1999) in Uganda and Mulatya (2000) in Kenya also observed that significant amount of wood materials can be produced from branch pruning of different tree species.

The tool used in crown pruning was machetes (panga), a local machete for cutting grass and wood, clearing bushes and weeds. Pruning saws were not used in crown pruning as farmers did not like them because they were not familiar with their use. Axe and hoes were used in root pruning.

Time taken in root pruning seemed to be relatively higher, as compared to crown pruning of any species at Siaya, and farmers may not, therefore, be willing to spend so much time in root pruning. However, the root pruning method used at Siaya site was probably more laborious (pruning was done in all direction to 30 cm depth) than

necessary, as most of the major lateral roots of all the four species in the test were found within the top 10 - 15 cm. Most *E. grandis* tree species have exposed roots on the very upper soil surface and, therefore, it is possible that farmers would only prune the major lateral roots, which would be found within the top 10-15 cm soil depth.

Time taken in root pruning *G. robusta* boundary trees in all sides at Siaya was 3 times (77 minutes/person/tree at Siaya and 24 minutes/person/tree at Nyabeda) greater than the time taken in root pruning of the same species in one side at Nyabeda. Most farmers plant pole trees along farm boundaries and, therefore, would only need to prune tree roots on one side of the trees. In this way, farmers would only prune those roots which are growing into the farm field. Farmers do not need to have special plans for root pruning. They could do it as they prepare their land for planting crops.

5.3.1.2 Tree responses to crown pruning

Tree crown pruning had no effect on survival and DBH growth of the four tree species. This is probably because mature trees were involved in this trial (Luckhoff, 1949; Adlard, 1969; Wormald, 1975; Karani, 1978). It is likely that results could have been different if young trees were pruned instead. The responses of trees to crown pruning and their ability to coppice and maintain similar diameter growth after pruning were also reported by Hocking and Islam (1998). Similar finding was reported by Namirembe (1999), where shoot pruning in the form of lopping showed no negative effect on survival of the trees.

All the four tree species in the test showed similar trends in DBH development. This suggests that farmers can prune mature trees that are grown adjacent to crops and at the mean time get even bigger diameter trees for sale as timber, while branches from crown pruning can be used as fuelwood and construction materials.

As noted earlier, tree pruning provides woody materials which can be used for meeting household wood needs. Mugo (1998) observed in Vihiga district, western Kenya, that *E. grandis* branch pruning of 1800 trees at age 4.5 years yields 0.75 tons (750 kg year⁻¹) enough to meet annual fuelwood need of a family of nine members.

5.3.1.3 Tree responses to root pruning

Trees responded very well to root pruning and no trees died due to root pruning. When farmers first saw the tree root pruning taking place at Siaya experimental site, they thought it was a crazy idea and expected all root pruned trees to be dead in just a few weeks time. They were, however, taken by surprise when they re-visited the site 5 months after tree pruning because, trees were still alive and they could not tell the difference between the root pruned trees and the ones which were not. To them, they both looked the same. For all the species, tree roots started to re-emerge at around two years after pruning.

5.3.2 Nyabeda

At Nyabeda site, *G. robusta* tree root pruning, in only one direction, was also a success story, as trees survived and continued to grow in both height and diameter.

The rate at which root pruned and both sides unpruned trees grew was the same. This shows that tree root pruning to 30 cm soil depth will not have any negative effects on tree survival or growths because, roots located below the pruning depth probably continued to function normally.

Tree pruning on only one side also helped in reducing time taken in root pruning. The time recorded in root pruning one *G. robusta* tree, in all direction at Siaya was 3 times (Table 4.2.4) more than the root pruning of the same age *G. robusta* tree in only one direction at Nyabeda. This means that the time spent in root pruning one tree in all directions could be used in pruning about 3 trees, if trees were to be pruned on only one side.

5.4 Soil water

5.4.1 Siaya

5.4.1.1 Soil water content in the upper 30 cm soil depth during three maize cropping seasons at Siaya

The introduction of trees into farming systems increases water use because trees utilize water outside the crop-rooting zone and also outside the crop-growing season (Huda and Ong, 1989). Thus, the inclusion of trees or shrubs on cropland may improve rainfall use efficiency either directly by using more rain through transpiration or indirectly by improved transpiration efficiency; more dry matter produced per unit of water used (Wallace, 1996). Trees reduce water losses and

therefore increase the availability of soil moisture by providing shade, reducing wind speed, increase infiltration by reducing rainfall intensity at the soil surface and improving soil structure (Budelman, 1987; Torquebiau and Kwesiga, 1996; Young, 1997). But they use water as well.

Although, the introduction of trees on cropland invariably increases water use, the overall productivity will only increase if the beneficial effects of trees compensate for the negative effects of competition for water, light and nutrients on crop yield (Cannell *et al.* 1996). Competition for water in AF systems can occur when the root systems of the tree and crop overlap (Van Noordwijk and Purnomoshidhi, 1995) and when water supply is limiting. This section discusses soil water status under the different tree/crop combinations and different pruning treatments compared to the unpruned trees (controls) and sole maize crop.

Tree crown and root pruning of all tree species in the test improved soil water status in the top 30 cm soil depth during the first 2-3 seasons after the application of tree pruning treatments (Tables, 4.3.2 & 4.3.3). The improvement in soil water status under pruned trees could be attributed to the decrease in tree transpiration rate (due to crown pruning) and changes in tree's soil water uptake zone (due to lateral root pruning). During the second maize growing season of short-rain 1999, %VSWC under *E. grandis* root pruned tree plots was higher than the sole maize. However, root pruned tree plots of *E. grandis* had more soil water content compared to only the unpruned (control) tree plots during the third season of long rain, April-May 2000.

For *E. grandis*, soil water content with 0-30 cm soil depth under crown and crown plus root pruned trees was the same as that under the unpruned (control) trees in the April-May 2000 assessment (Table 4.3.4). Crown and crown plus root pruned *E. grandis* trees had already regained their branches (due to branch re-growth) and therefore, were not different from the un-pruned (control) trees plots during April-May 2000 period. This indicates that the recovery of the lateral roots after pruning takes longer time than the coppicing of shoots.

However, during the June-July 2000 assessment, soil water content for all pruning treatments under *E. grandis* tree plots were statistically the same, indicating the recovery of lateral roots. Although tree root re-growth was not optimum, field observation indicated that 20-50% re-growth of roots could be sufficient in absorbing water and nutrients from 20-30 cm soil depth at Siaya. Hocking and Islam (1998) reported that tree root re-pruning in Bangladesh is done annually because, tree root regrowth, even in small proportion, can be as competitive as trees that are not root pruned at all.

5.4.1.2 Changes in soil water content with increase in soil depths

The tree species showed different patterns of water depletion down the soil profile. Generally, the highest water depletion occurred under *C. equisetifolia* followed by *G. robusta* and *E. grandis* while the least water depletion occurred under *M. lutea*.

For all the tree species and pruning treatments, early in the maize growing seasons (April-May) of the long and short (September-October) rains the soil-stored water was significantly depleted in the top 0-20 cm of the soil profile as compared to other depths (Table 4.3.8). As the season progressed in the long rain 2000, water depletion extended further to 20-40 cm soil depths in all tree plots.

During the third maize growing season of the short rain 2000, water depletion occurred within the top 0-60 cm soil depths and interestingly %VSWC for *C. equisetifolia*, *E. grandis* and *G. robusta* increased significantly within 60-80 cm soil depth and then dropped significantly within 80-100 cm soil depth. However, the %VSWC at 80-100 cm soil depth did not differ from that of 20-40 cm soil depth but was significantly less than that of the 60-80 cm soil depth. An exceptional case was noted for *M. lutea* tree plots where water depletion was concentrated within the upper 0-40 cm soil profile only and was having similar trends as the sole maize plots (Table 4.3.9). The logical explanation to this is that soil water from top 20-40 cm was taken up by adjacent maize crops while soil water within 80-100 cm was taken up by trees, as zone of soil water uptake by trees had been altered from upper soil surface to deeper soil horizons due to lateral root pruning (Zhang, 1996).

General comparison of pruning treatments shows that water depletion for the control un-pruned plots occurred in the top 20-80 cm soil depth in all the tree species. Water content between 20-60 cm soil depths was high for crown and root pruned treatments followed by crown-pruned tree plots except during the driest periods. When the soil profile was dry, root pruned tree plots contained more water content within the top

20-60 cm soil depths while crown pruned treatments had less (Figures, 4.3.4, 4.3.5 & 4.3.6).

The possible explanation for this could be that, the upper soil surface under crown pruned trees is exposed to direct sun light during the drier period and hence higher soil surface evaporation, and vice versa for soils under root pruned tree plots. On the contrary, the upper soil surface under root only pruned tree plots was sheltered from the direct sun light and hence the reason for higher %VSWC.

It is generally accepted that trees will preferably extract water from the topsoil when soil water is distributed uniformly (ICRAF, 1994; Zhang, 1996). When trees were, however, root pruned within the top 30 cm depth, they were forced to use water, which was available below the crop rooting zones by using their taproots (Zhang, 1996).

It has been observed that the zone of maximum root water uptake moved progressively from shallower to deeper depths as the soil dried, and the amount of water taken up from any given layer depended on both the distribution of soil water and rooting density Zhang (1996). It was also found that when the soil profile was uniformly wet, water uptake mainly occurred in the surface layers, which had the highest root density. As the soil dried, the deeper soil layers, which were wetter than the surface layers, contributed more to total water uptake despite having lower rooting density. Livesley (1999) found that water extraction by *Grevillea robusta* trees was greater in the topsoil than in the deeper soil layers. On the other hand,

Howard *et al.* (1997) found that *Grevillea robusta* utilized water from below the crop rooting zone (> 60 cm depth). In the semi arid part of Kenya, Odhiambo (1999), however, reports that *Grevillea robusta* exclusively utilized water from deep horizons, but there was also an overlap in water use between *Grevillea robusta* and maize in the topsoil. This shows that trees are able to shift their zone of water extraction, depending on the availability and accessibility of water in the soil horizon. Similarly, the present study showed that when tree lateral roots are removed from the upper soil surface, trees were forced to extract water through their tap roots, from deeper soil layers.

5.4.1.3 Effect of increasing distance from tree line on soil water content

A significant increase in %VSWC on the top 30 cm soil surface with increase in distance from the tree line was noted under *E. grandis* during the first season (long rain 1999). Crown, root and crown plus root pruned *E. grandis* trees increased VSWC by 25-50% (Figure 4.3.1) as compared to the un-pruned (control) tree plots in all the distance measured while similar VSWC increase was noted under crown and crown plus root pruned plots of *C. equisetifolia* as compared to the unpruned (control) plots. *Grevillea robusta* and *M. lutea* also showed an increase in %VSWC with distance but no significant differences were noted between pruning treatments, during all cropping seasons.

The effect of distance from tree lines on water loss have been reported for *Grevillea* (Livesley, 1999; Odhiambo, 1999), *Populus* (Zhang, 1996), *Eucalyptus* (Malik and Sharma, 1990; Khybri et al., 1992; Onyewotu et al., 1995), *Grewia optiva* and *Morus alba* (Khybri et al., 1992), *Alnus*, *Casuarina*, *Maesopsiss* and *Markhamia* (Okorio, 2000).

In general, soils close to crown and root pruned trees of all tree species had more %VSWC than soils close to the unpruned (control) trees and followed similar trends for all the distances measured from tree line. This shows that crown pruned trees of all species at all distance demanded less soil water as compared to the unpruned (control) trees. Root pruned trees used water which was below 30 cm soil depth, due to lateral root pruning, and therefore, soil water under root pruned trees on top 30 cm depth at all distance from tree line was less exploited as compared to soil water under the unpruned (control) trees at all distances measured. The increase in %VSWC under pruned trees with increasing distance from tree line, however, shows that the effect of trees on %VSWC is improved by tree pruning but not totally eliminated. Soil water was still being utilized by pruned trees.

The effect of distance from tree line in relation to soil depths, as measured by neutron probe, on %VSWC as well as its interaction with species, pruning treatments and soil depths during the third maize cropping season short rain 2000 was not statistically ($P>0.05$) different. This was mainly because, soil measurement in reference to soil depth by neutron probe was not started until the third maize cropping seasons. By the time this measurement started, most pruned branches and

pruned roots were regrowing and, therefore, were may be as competitive as the unpruned (control) trees.

5.4.2 Nyabeda

5.4.2.1 Soil water content during three maize cropping seasons at Nyabeda

Plots with one side root pruned boundary planted *G. robusta* trees at Nyabeda didn't differ from the unpruned (control) tree plots. However, the other side unpruned tree plots were having significantly less %VSWC than the one side pruned and the both sides unpruned (control) tree plots during the driest months of April-May. The sole maize was always having the highest %VSWC. The significantly less %VSWC observed in one side unpruned tree plots was may be due to the fact that tree respiration demand was mainly met by trees which sides were not root pruned.

5.4.2.2 Changes in soil water content with increase in soil depths

Generally, soil water content increased with increasing depth. Sole maize plots contained more %VSWC at all assessment depths (20-200 cm) as compared to the one side root pruned and the other side unpruned tree plots during the first three maize growing seasons after tree root pruning. The both sides unpruned (control) tree plots had significantly less %VSWC in the upper 20 cm soil depth compared to the one side root pruned and the other side unpruned (control) tree plots but no significant differences were observed for %VSWC between root pruning treatments

below 20 cm soil depth. This is mainly because of changes in the zone of water extractions due to tree root pruning.

5.4.2.3 Effect of increasing distance from tree line on soil water content

Soil water content increased with increasing distance from *G. robusta* boundary tree lines in all the treatment plots and on all measurement occasions. The effects of increasing distance from *Grevillea robusta* and *Gliricidia* tree lines on water loss have also been reported by Livesley (1999), Odhiambo *et al.* (1999) and Ong *et al.* (1999). The both sides unpruned (control) tree plots had more %VSWC than the one side pruned while the one side root pruned plot was significantly the least in %VSWC from 1.5 to 4.85 m distance from tree line.

Trees at Nyabeda were only root pruned on one side but not crown pruned and, therefore, tree transpiration demands in one side pruned and the other side unpruned (control) trees were probably met by the unpruned side of superficial roots and probably the reason for significantly less %VSWC under the pruned trees than the unpruned (control) trees. This suggests the needs for crown pruning when trees are root pruned on only one side.

5.5 Sap flow

Sap flow measurements have been used in estimating transpiration rates in conditions where soil moisture is limited (McIntyre *et al.*, 1996) especially where atmospheric demand exceeds transpiration rates. Schulze *et al.* (1985) observed that sap flow movement was closely related to transpiration rates and could therefore be used to measure transpiration rates. The heat pulse method was recommended as most appropriate for estimating transpiration rates of trees (Hatton *et al.*, 1995). Consecutively, it was used in this study.

A short-term effect of crown and lateral root removal on sap flow of the crown and root pruned *C. equisetifolia* and *G. robusta* trees at Siaya was studied in relation to their un-pruned (control) trees. Similar study was also undertaken on *G. robusta* boundary planned trees at Nyabeda site.

It is obvious that tree rate of transpiration is reduced due to low leaf area index resulting from crown pruning. However, we know very little as to what happens to tree's transpiration demand when parts of water conductive tree root are removed from a tree.

5.5.1 Siaya

Crown pruning of *C. equisetifolia* and *G. robusta* reduced water loss through transpiration by more than 50% while root pruning of both species increased tree transpiration by about 25% as compared to the unpruned control trees (Figures, 4.4.1 & 4.4.2). Recent work done on sap flow from lateral tree root pruning in Uganda also showed that roots that were located more deeply in the soil increased rates of sap flow to satisfy transpiration demand from the atmosphere, after tree lateral roots were cut (Ong *et al.*, 2000).

The result of other studies (Mulatya, 2000) indicated that transpiration rate of trees is positively influenced by radiation, temperature and tree size. Namirembe (1999) also observed that when leaf area of *Senna spectabilis* was reduced by removing some of the leaves there was drastic reduction in transpiration rate of the trees.

The most important finding in this study is that tree root pruning in the top 30 cm did not affect tree's transpiration demand, as the root pruned trees transpired statistically more than the un-pruned (control) plots. Both *C. equisetifolia* and *G. robusta* showed similar trends in their water uptake over time and both species showed that when tree lateral roots are cut the roots which are below 30 cm soil depth will extract more water so that both tree transpiration requirement and growth resources for the recovery of cut roots are met at the same time (Figure 4.4.1 & 4.4.2). This shows how the competitiveness of trees could be reduced by hydraulic shift by enhancing

the availability of water to crops in the upper soil horizon (Dawson, 1996; Smith *et al.*, 1999).

5.5.2 Nyabeda

Trees of the same size of *G. robusta* were taken for sap flow measurement. Result shows that trees which were root pruned on one side transpired about 50% more than the unpruned trees (Figure 4.4.3). This shows that when trees are root pruned on only one side the other sides, which are not root pruned, may work hard to compensate for what is lost on the pruned side, and will take up more water. Lott *et al.*, (1996) reported that when tree lateral roots were removed tree transpiration demand was met by deeper roots penetrating into fissures in the underlying friable bedrocks.

5.6 Light interception by maize crops in boundary planted trees at Slaya

The amount of light intercepted by trees varied between trees species and pruning treatments (Table 4.5.2). Light interception by trees was reduced due to crown pruning and increased the proportion of light reaching the maize canopy and hence the proportion of light intercepted by maize as compared to the unpruned (control) tree plots. This shows that crown pruning can reduce tree shading effect by boundary planted trees.

The presence of trees significantly reduced the fraction of light intercepted by maize. Negative effect of tree shading on yield of adjacent crop in unpruned hedgerow plantings were also reported elsewhere (Daniel *et al.*, 1991; Corlett *et al.*, 1992b;

Howard *et al.*, 1995; Miah *et al.*, 1995; Zhang, 1996; Lott *et al.*, 1997, Ssekabembe *et al.*, 1997; Newman *et al.*, 1998).

Crown and a combination of crown plus root pruned trees of all the four species reduced shading of trees on crops. Shading of trees, however, decreased with an increase in distance from the tree lines. In general, light availability to the understorey maize was lowest in rows that were closest to tree lines and the highest in those further away. It, however, varied according to the tree species and the types of tree pruning treatment applied.

Maize in tree plots which were crown pruned and crown plus root pruned had the highest rate of light interception while the un pruned (control) and the root only pruned tree plots had the lowest (Figures, 4.5.1, 4.5.2 & 4.5.3). The variability of light interception by maize was observed up to 4 m from the tree lines for all the species and cropping seasons. The work done by Lott *et al.* (2000) in semiarid Kenya also showed that the above ground biomass and grain yield of understorey crops were not significantly affected by the presence of *G. robusta* trees during the first four seasons, but were greatly reduced in subsequent seasons as the trees became increasingly dominant.

At the early stage of tree pruning, no significant differences were observed for fraction of PAR that was intercepted by maize between the sole maize and the crown pruned tree plots of all the four species. During the following maize cropping seasons the PAR that was intercepted by the sole maize plots was significantly higher

for the first two rows from tree lines of all the species. This was mainly due to the recoppicing of shoots and hence an increase in tree shading on the adjacent crops.

5.7 Maize growth and yield response to tree crown and root pruning

5.7.1 Siaya

There is little information in the literature on this type of AF system in which to compare results with the present study. Maize height and root collar diameter under the crown and root pruned tree plots were higher for all the tree species in the test. Both maize height and root collar diameter for all the treatments increased with time but root collar diameter was lower at 8th week assessment than the 6th week assessment, in a few cases (Table 4.6.2).

This may be due to the fact that the maize plants were losing moisture and were in the process of drying up and also peeling off some of their outer bark, even much ahead of the maize tussling time. Growth parameters of maize, were not, therefore, considered as good indicators of maize production, due to the fact that collar diameter was smaller in the later stages than the early stages of maize development, and therefore monitoring maize growth was terminated after one season and the emphasis was given to maize yield assessments in terms of cobs and grain dry weights.

The magnitude of the effect of tree pruning on maize growth and yield, however, varied between species. Results from this study have demonstrated that growing maize in close proximity to the unpruned trees significantly reduced maize growth and yields (Tables 4.6.2, 4.6.3, 4.6.5 & 4.6.6). Crop yield reductions caused by competitive effect of the unpruned trees observed in the study are in agreement with most previous studies, where trees have been grown in mixture with crops (Mwihomeke, 1990; Okorio *et al.*, 1994; Akyeampong *et al.*, 1995; Namirembe, 1999; Okorio, 2000).

Crown and root pruning of all tree species increased soil water in the top 20-30 cm soil layer and therefore more water was available within the crop rooting zone where maize plants were able to take it up (Figure, 4.7.1). Crown pruning also reduced the shading effect on associated maize and when soil water was not a limiting factor maize yield was increased due to the reduction of shade by crown pruning (Figure 4.7.2).

Competition for light has been observed to cause reduction in crop yields in various AF systems (e.g., *Leuceana leucocephala* with maize, Kang *et al.* 1981; Srinivasan *et al.* 1990). Shading by *Leuceana leucocephala* caused reduced yield of *Zea mays* and *Vigna sinensis* growing adjacent to it (Karim *et al.* 1991).

The overall maize grain yield increase under all tree crown and crown plus roots pruned trees during the first three seasons can mainly be attributed to the increase in soil water, due to both crown and root pruning of trees and decrease in tree shade,

due to crown pruning. Maize yield under all the tree species under the root pruned trees started to decline at the end of the 4th cropping season and did not differ from maize yield under the unpruned (control) trees. This is mainly due to the re-growth of lateral roots into the crop rooting zones (30 cm depths). This suggests that root pruned trees with regrowth of only 20-50% in the upper soil layer may take up the same amount moisture as that of the unpruned (control) trees.

Both tree crown and root-pruning treatments at Siaya increased crop yield by 50-80%, during the first and second seasons after pruning, as compared to the unpruned (control) trees. In extreme instances, un-pruned trees caused complete crop failures (Figure 4.6.1). Although some of the cut root ends in Siaya have regenerated, the beneficial effects on crop yields appear to persist for at least 3 seasons (about 18 months after pruning) suggesting the need for frequent root re-pruning boundary planted trees.

When maize biomass (cobs and stover dry weight added) was pooled for species, maize yield under the pruned trees increased with decreasing distance from the tree lines, while maize yield under the unpruned (control) trees increased with increasing distance from the tree lines, during the first season of the long rain 1999 (Figure 4.6.3).

The increased maize yield close to the trees than away from the trees was probably caused by improved soil nutrients under the pruned trees associated with litter fall and dead roots from tree root pruning. Rao *et al.* (1998) reported improved millet

yield under *Parkia biglobosa* trees because of enhanced soil nutrients under the trees. Improved maize yields under *Melia volkensii* tree canopies were also reported Mulatya (2000). The increase in maize biomass yield under the pruned trees as compared to the sole maize in some cases can still be attributed to improved soil fertility by the tree litter fall from crown pruning and dead root cuts during pruning and also to favourable micro-climate provided by trees (Akeyeampong *et al.*, 1999) or complementarity in water use by the trees and crops (Howard *et al.*, 1995).

Generally, maize grain yield was related to soil water (Figure 4.7.2 & 4.7.3) and the amount of PAR reaching the maize crops and intercepted by maize canopy (Figure 4.7.5). Maize grain yield for all seasons, species and pruning treatments was highly influenced by %VSWC (71%) while PAR showed less effect (47%) on maize grain yield produced.

Increased rainfall also increased soil water and hence increased maize yields. Crown and crown plus root pruned trees increased soil water which lead to higher maize yield. Crown pruned trees of all the four species had more significant positive effects on maize yield than their root pruned plots at the early stages after tree pruning.

5.7.2 Nyabeda

The Nyabeda *G. robusta* root pruned tree plots in only one direction increased maize yield significantly in the first two cropping seasons (Table 4.6.7). The significant differences in maize yield, however, ceased during the third maize cropping season in which all treatment plots were statistically the same.

The lack of significant effect during this season could be attributed to the unusually reduced amount of rainfall received. The re-emergence of cut roots back in the upper soil surface might have also contributed to the reduction of maize yield. This was likely due to the absorption of soil water from the top 30 cm soil depth by the newly regrowing roots from the end of the cut roots.

During the fourth season of maize growing, maize yield in the both sides un-pruned (control) tree plots was higher than the one side pruned and the other side unpruned tree plots (Table 4.6.7). This suggests that, when trees are subject to only root pruning, they work very hard to get their cut roots back so that the tree's transpiration demand is met from both the upper and lower soil surfaces.

Therefore, if a farmer wants to extend the positive effects of pruning on maize yield for a longer period of time and avoid the drastic negative effects of the newly emerging roots on maize yield, it is advisable to have both crown and root pruning done simultaneously.

Maize grain yield increased as distance of maize rows increased from tree lines (Figure 4.6.5). This is due to the presence of unpruned tree roots in the other side and tree shading, as trees were not crown pruned, as it was the case in Siaya.

Okorio et al. (1994) reported the competitive effects of different boundary planted trees in relation of distance of maize crops from tree lines. According to his report, crop yield reduction up to 3 to 4 m from the tree rows ranged from 60% (under *Maesopsis eminii*) to 38% (under *Markhamia lutea*). Khybri et al. (1986) also reported the extended (up to 5 m) depressing effect of *Morus alba* and *Grewia* trees on wheat yield. Wheat yield close to the trees were significantly lower than those away from the trees.

CHAPTER SIX

6.0 CONCLUSIONS AND RECOMMENDATIONS

Based on the results of this study and subsequent discussion, the following main conclusions and recommendations can be drawn.

6.1 Conclusions

- **Farmers' survey in western Kenya revealed that trees intercropped with agricultural crops in the area resulted in competition between trees and crops.**
- **Farmers will intercrop trees and crops; and will crown and root prune trees if provided with material and technical advises from concerned agencies.**
- **Trees of all species in the test at Siaya and Nyabeda sites survived both heavy crown and root pruning without any reduction in tree growths.**
- **A large amount of fuelwood was produced from crown pruning at Siaya. The pruned woody materials from crown pruning were used as fuelwood.**
- **Crown pruned trees of all species sprouted and coppice branches continued to grow in both length and diameter.**

- **Soil water under crown and root pruned trees of all species in the test was significantly higher compared to soil water under the unpruned (control) trees.**
- **Soil water under all trees increased as distance from tree line increased but it was higher under pruned trees than under unpruned trees at all distances measured.**
- **Tree crown pruning reduced tree water uptake resulting in an increase in soil water while tree root pruning redirected tree water uptake zones from the upper soil layer to that below crop root growing zones.**
- **The fraction of incoming PAR that was incident on the under-storey maize crop was significantly increased by crown pruning.**
- **Maize crop adjacent to crown and root pruned trees grew significantly better and produced significantly higher maize yield as compared to that growing adjacent to the unpruned (control) trees, during the first 3 maize cropping seasons.**
- **Maize yield decline at the end of the third cropping season (about 2 years after pruning) is due to regrowing of tree branches and tree lateral roots.**

6.2 Recommendations

- Different tree species have different competitive ability. It would, therefore, be useful to study the age at which competition of different trees with crops set in.
- Effects of crown and root pruning on soil water, light and crop yield also need to be monitored along with tree growths over time so that tree crown and root re-pruning cycles can be determined more precisely.
- Higher transpiration rate by the root pruned trees as compared to the unpruned trees is a new finding and need to be supported by more studies with reference to tree species and contrasting environments.
- Based on maize yield production, crown only pruning is recommended for *M. lutea* and *E. grandis* trees while crown plus root pruning is recommended for *C. equisetifolia* trees. Root only pruning is recommended for *G. robusta* trees.
- Most farmers are interested in pruning trees that are growing along agricultural field boundaries if provided with assistance on how to prune them. Therefore, tree pruning technology transfer to farmers in the area should start as soon as possible.
- Training farmers on safety rules and regulations of crown pruning big trees is very essential and, therefore, need to be undertaken before farmers begin to implement the technology.

REFERENCES

- Acevedo, E., Hsiao, T.C. and Henderson, D.W. (Eds.) (1971). Variation in root morphology of *Faidherbia albida* in relation to soil and agronomic effects. In: *Faidherbia albida* in the West African semi-arid tropics. International Centre for Research in Agroforestry, Nairobi. 206pp.
- Adlard, P.G. (1977). Spacing and thinning of young *P. patula* in Malawi. *Commonwealth Forestry Review* 48(4): 339-349.
- Agroforestry Research Network for Africa (1997). *AFERNA Progress and Technical Report*. Nairobi, Kenya, 122: pp. 45-56.
- Ahmed, S. and Rao, M.R. (1982). Performance of a maize/soybean intercrop combinations in the tropics: Results of multi-locational study. *Field Crops Research* 5: 147-161.
- Akyeampong, E., Hitimana, L., Franzel, S. and Munyemana, P.C. (1995). The agronomic and economic performance of banana, bean and tree intercropping in the highlands of Burundi: and interim assessment. *Agroforestry Systems* 31: 199-210.
- Akyeampong, E., Hitimana, L., Torquebiau, E. and Munyemama, P.C. (1999). Multi-strata AF with beans, bananas and *Grevillea robusta* in the highlands of Burundi. *Experimental Agriculture* 35: 357-369.
- Anderson, J.M. and Ingram, J.S.I. (Eds.) (1993). *Tropical soil biology and fertility*. A hand book of methods, second edition, UK, 221pp.
- Anderson, L.S. and Sinclair, F.L. (1993). Ecological interactions in Agroforestry Systems. *Agroforestry Abstracts* 6: 58-91.

- Arnold, J.E.M. and Dewees, P.A. (1997). *Farms, trees and farmers*. Earthscan Publications Ltd., London, 292pp.
- Baker, D.A. (1984). Water relations. In: *Advanced plant Physiology*. M.B.Wilkins (Ed.). John Wiley & Sons inc. NY. pp. 59-73.
- Baker, J.M. and Van Bavel, C.H.M. (1987). Measurement of sap flow in the stems of herbaceous plants. *Plant, Cell and Environment* 10: 777-782.
- Baker, J.M. and Niebier, J.L. (1989). An analysis of the steady-state heat balance method for measuring sap flow in plants. *Agricultural Forest Ecology* 48: 93-109.
- Batchelor, C.H. and Roberts, J.M (1983). Evaporation from the irrigation water. Foliage and panicles of paddy rice in north-east Sri Lanka. *Agricultural Meteorology* 29: 11-26.
- Beer, J. (1987). Advantages and disadvantages and desirable characteristics of shade trees for coffee, cacao, and tea. *Agroforestry Systems* 5: 3-13.
- Bell, J.P. (1987). Neutron probe practice. NERC Institute of Hydrology, Wallingford, Report No. 19: 51pp.
- Beyschlag, W., Barnes, P.W., Ryel, R., Caldwell, M.M. and Flint, S.D. (1990). Plant competition for light analyzed with a multi-species canopy model. 2. Influence of photosynthetic characteristics on mixtures of wheat and wild oat. *Oecologia* 82: 374-380.
- Black. W.S., Tang, D.Y., Ong, C.K., Solon, A. and Simmonds, L.P. (1985). Effects of soil moisture stress on the water relations and water use of groundnut stands. *New Physiologist* 100: 213-328.

- Blackburn, W.J. and Proctor, H.T.A. (1983). Estimating photosynthetically active radiation from measured solar irradiance. *Solar Energy* 31: 233-234.
- Bohm, W. (Ed) (1979) *Methods of studying Root Systems*. Springer, Berlin, 188pp.
- Booker, R.E. and Swansson, R.H. (1979). *Radial variation of longitudinal permeability over a tree cross section for a number of conifers*. Newzeland Forest Service. Forest Research Institute. Forest Products Timber drying Division, Newzeland, 145pp.
- Bowen, W. (1985). Roots as component of tree productivity. In: *Attributes of trees as crop plants*. (Edited by Cannel, M.G.R and Jackson, G.E) Institute of Terrestrial Ecology, Huntingdon. pp. 303-315.
- Brandle, J.R, James R., Johnson, B.B. and Dearmont, D.D. (1984). The case of winter wheat production in eastern Nebraska. *Journal of Soil and Water Conservation* 35: 329-343.
- Buck, M.G. (1986). Concept of resource sharing in AF systems. *Agroforestry Systems* 4: 191-203.
- Budelman, A. (1987). The above ground structural compatibility of *Flemingi macrophylla*, *Gliricidia sepium* and *Leuceana leucocephala* as live stakes for yams, *Dioscorea alata*. Proceedings of International workshop on *Gliricidia sepium* (Withington, D. et al. Eds). Agricultural University of Wagenigen, Netherlands, pp. 82-89.
- Buresh, R.J. and Tian, G. (1997). Soil improvement by trees in sub-Saharan Africa. *Agroforestry Systems* 38: 51-76.

- Callaghan, T.V., Lawson, G.J., Millar, A. and Scott, R. (1986). *Environmental aspects of Agroforestry*. A discussion on research and development requirements. Ministry for agriculture, fisheries and food, London, pp. 50-76.
- Campbell, C.D. and Dawson, L.A. (1992). Below ground competition between trees and grass in a silvopastoral system. *Agroforestry in the U.K.* 2(3): 39-43.
- Cannell, M.G.R., Van Noordwijk, M. and Ong, C.K. (1996). The central Agroforestry hypothesis: the trees must acquire resources that the crop would not otherwise acquire. *Agroforestry Systems* 34: 27-31.
- Chartier, M., Bonchretien, P., Allirand, J.M., and Gosse, G. (1989). Utilisation des cellules au silicium amorphe pour la mesure du rayonnement photosynthetiquement actif (400-700 nm). *Agronomie* 9: 281-284.
- Chew. V. (1977). Comparisons among treatment means in an analysis of variance. Agriculture Research service of United States Department of Agriculture, 64pp.
- Chirko, C.P., Gold, M.A., Nguyen, P.V and Jiang, J.P (1996b). Influence of orientation on wheat yield and photosynthetic photon flux density (Q_p) at the tree and crop interface in a Paulwina–Wheat Intercropping system. *Forest Ecology Management* 89: 149-156.
- Clarke, J. (1991). Participatory technology development in Agroforestry: Methods for a pilot project in Zimbabwe. *Agroforestry Systems* 15: 217-288.
- Cohen, Y., Takeuchi, S., Nazaka, J. and Yano, T. (1993). Accuracy of sap flow measurements using heat balance and heat pulse methods. *Agronomy Journal* 85: 1080-1086.

- Comstock, J. and Ehleringer, J. (1993). Stomatal response to humidity in common bean (*Phaseolus vulgaris*): implication for maximum transpiration rate, water-use efficiency and productivity. *Australian Journal of Plant Physiology* 20(6): 669-691.
- Cook, H.F and Dent, D.L. (1990). Modelling soil water supply to crops. *CATENA* 17: 25-39.
- Cooper, P.J.M., Leaky, R.R.B., Rao, M.R. and Reynolds, L. (1996). Agroforestry and the mitigation of land degradation in humid and sub-humid tropics of Africa. *Experimental Agriculture* 32: 235-290.
- Corlett, J.E., Ong, C.K., Black, C.R. and Monteith, J.L. (1992b). Above and belowground interactions in a *Leuceana*/millet alley cropping system. I. Experimental design, instrumentation and diurnal trends. *Agricultural and Forest Meteorology* 60: 73-91.
- Corlett, J.E., Ong, C.K., Black, C.R. and Monteith, J.L. (1992a). Above and belowground interactions in a *Leuceana*/millet alley cropping system. II. Light interception and dry matter production. *Agricultural and Forest Meteorology* 60: 73-91.
- Daniel, J.N., Ong, C.K. and Kumar, M.S. (1991). Growth and resource utilization of perennial pigeon-pea (*Cajanus cajan* (L) Millsp.) at the tree-crop interface. *Agroforestry Systems* 16: 177-192.
- Dawson, T.E. and Pate, J.S. (1996). Seasonal water uptake and movement in root systems of Australian phreatophytic plants of dimorphic root morphology: a stable isotop investigation. *Oecologia* 107-1: 13-20.

- Dhyani, S.K., Chauhan, D.S., Singh, B.P. and Prasad, R.N. (1996). Tree effect on yield and quality of pineapple (Kew) in a silvo-horti system of Agroforestry. *Range Management and Agroforestry* 6: 89-93.
- Donald, C.M. (1958). The interaction of competition for light and nutrients. *Australian Journal of Agricultural Research* 9: 421-435.
- Doyle, C.J., Evans, J. and Rossiter, J. (1984) An economic appraisal of the benefits of intercropping trees with grassland in lowland Britain. *Agricultural Systems* 21: 1-32.
- Doran, C.J. and Turnbull, J.W. (1997). *Australian trees and shrubs: species for land rehabilitation and farm plantings*. ACIAR, Australia, 124.
- Drew, M.C. He, C.J. and Morgan, P.W. (1990). Decreased ethylene biosynthesis and induction of aerenchyma by nitrogen-or phosphate-starvation in adventitious roots of *Zea Mays* L. *Plant Physiology* 91: 266-271.
- Edwards. W.R.N. and Warwick, N.W.M (1984). Transpiration from a kiwi fruit vine as estimated by the heat pulse technique and Penman – Montienth Equation. *New- Zealand Journal of Agricultural Research* 27: 537-543.
- Eeles, C.W.O. (1969). Institute of Hydrology. Report No. 7. Wallingford, England.
- Erskine, J.M. (1991). Agroforestry: Its development as a sustainable productive land use system for low resource farmers in South Africa. *Forest Ecology and Management* 45: 281-291.
- Etherington, J.R. (1975). *Environment and plant ecology*. John Willy and Sons Ltd. London, 267pp.

- Evans, J. (1988). *Overview of tree planting on small farms in the Tropics*.
International Institute for Environment and Development, London, UK,
125pp.
- FAO/UNESCO (1988) Soil map of the world, 1: 5000 000 Volume 6, Africa.
UNESCO, Paris, France.
- Ferber, A.E., Ford, A.L. and Mccrory, S.A. (1955). *Good windbreaks help increase
Crop yields*. South Dakota, 118pp.
- Fischer, R.A. (1980). Influence of water stress on crop yields in semi-arid regions.
In: *Adoption of plants to water and high temperature stress*. Turner, N.C. and
Kramer, P.J. (Eds). John Wiley and Sons, 323-339pp.
- Frank, A.B., Harris, D.G. and Willis, W.O. (1974). Windbreak influence on water
relations, growth and yield of soybeans. *Crop Science* 14: 761-765.
- Franzel, S. (1992). *Diagnosing farmers' problems with special reference to
Agroforestry*. Socioeconomic Research for AF Systems Development.
Proceedings of International Centre for Research in Agroforestry, ICRAF,
Nairobi, September 2-6, pp. 45-56.
- Franzel, S. (1996). *Report on 'Developing a Questionnaire for a Formal Survey of
Rural Households'*. International Centre for Research in Agroforestry
(ICRAF), Nairobi, Kenya, 20pp.
- Granier, A. (1987). Evaluation of transpiration in a Douglas-fir stand by means of
sap flow measurements. *Tree Physiology* 3: 309-320.
- Gillespie, R.A. (1989). Modelling nutrient flux and inter-species root competition in
Agroforestry inter-planting. *Agroforestry Systems* 8: 257-265.

- Granier, A., Anfodillo, T., Sabatti, M., Cochard, H., Dreyer, E., Tomasi, M., Valentini, R. and Breda, N. (1994). Axial and radial water flow in trunks of oak trees: a quantitative and qualitative analysis. *Tree Physiology* 14: 1383-1396.
- Granier A., Biron, P., Breda, N., Pontaillier, J.Y. and Saugier, B. (1996). Transpiration of trees and forest stands: short and long term monitoring using sap flow methods. *Global Change Biology* 2: 265-274.
- Greacen, E.L., Ponsana, P. and Barley, K.P. (1976). Resistance to water flow in the roots of cereals. In: *Water and Plant Life*. Edited by O.L. Lange, L. Kappen, and E.D. Schulze. *Ecological Studies* 19: 86-100, Berlin Heidelberg New York.
- Green, S.R. and Clothier, B.E (1988). Water use of Kiwi fruit and apple trees by the heat pulse technique. *Journal of Experimental Botany* 39: 115-123.
- Greenwood, E.A.N., Beresford, J.D., Bartle, J.R. and Barron, R. J.W. (1992). Evaporation from vegetation in landscapes developing salinity using the ventilated chamber technique. IV. Evaporation from regenerating forest of *Eucalyptus wandoo* on land formerly cleared for agriculture. *Journal of Hydrology* 58: 357-366.
- Grime, V.L. (1992). Thermal methods for measuring sap flow through intact plant stems: an evaluation of methods and their application for determining the factors controlling transpiration in a stand of heterogeneous natural vegetation: a case study for *Gueria senegalensis*, the dominant woody shrub species in the fallow savanna of Niger. PhD Thesis. Department of Soil Sciences and Meteorology, University of Reading, UK, pp. 76-87.

- Grime, V.L., Morison, J.I.L. and Simmonds, L.P. (1995a). Including the heat storage term in sap flow measurements with the stem heat balance method. *Agricultural and Forest Meteorology* 74: 1-25.
- Grose, M.J. and Hainsworth, M. (1992). Soil water extraction, measured by computer assisted tomography in seeding *Lupinus angustifolus* CV. Yandee when healthy and when infected with *Phytophthora cinnamoni*. *Journal of Experimental Botany* 43: 121-127.
- Hagger, J.P. and Ewel, J.J. (1997). Primary productivity and resource partitioning in model tropical ecosystems. *Ecology* 78(4): 1211-1221.
- Hailey, J.L., Hiler, E.A., Jordan, W.R. and Van Bavel, C.H.M. (1973). Resistance to water flow in *Vigna sinensis* L. (Endl.) at high rate of transpiration. *Crop Science* 13: 264-267.
- Harrison, P. (1987) *The greening of Africa: breaking through in the battle of land and food*. Paladin, London, 254pp.
- Harwood, C.E. and Getahun, A. (1990). Australian trees find success. *Agroforestry Today* 2(1): 5-8.
- Hatton, T.J., Catchpole, E.A. and Vertessy, R.A. (1990). Integration of sapflow velocity in elliptical stems. *Tree Physiology* 11: 185-196.
- Hatton, T.J., Moore, S.J. and Reece, P.H. (1995). Estimating stand transpiration in *Eucalyptus populnea* woodland with heat pulse method: measurement errors and sampling strategies. *Tree Physiology* 15: 219-227.
- He, C. J., Morgan, P.W. and Drew, M.C. (1992). Enhanced sensitivity to ethylene in nitrogen-or phosphate-starved roots of *Zea Mays* L. during aerenchyma formation. *Plant Physiology* 98: 137-142.

- Heine, R.W. and Farr, D.J. (1976). Comparison of heat pulse and radioisotope tracer methods for determining sap flow velocity in stem segments of poplar. *Journal of Experimental Botany* 24(81): 649-654.
- Hocking, D., Sarwar, G. and Yousuf, S.A. (1997). Trees in Bangladesh: Crop yield underneath traditionally managed mature trees. *Agroforestry Systems* 35(1): 1-13.
- Hocking, D. and Islam, K. (1998). Trees on farms in Bangladesh: 5 Growth of top- and root pruned trees in wetland rice fields and yields of understory crops. *Agroforestry Systems* 39: 101-115.
- Hoekstra, D.A. and Djimde, M. (1988). *Agroforestry Research Potentials for the Highlands of Uganda. AFRENA Report no. 4*, ICRAF, Nairobi, 70pp.
- Hoekstra, D.A., Aluma, J.R.W., Thijsen, H.J.C., Muwanga, J. and Sekyale, I.B. (1991). *Diagnostic study of banana-coffee associations in the intensive Banana-Coffee Lake-Shore System. AFRENA Report No. 44*. ICRAF, Nairobi, 15pp.
- Hooper, D.U. (1998). The role of complementarity and competition in ecosystem responses to variation in plant diversity. *Ecology* 79: 704-719.
- Howard, S.B., Ong, C.K., Black, C.R. and Khan, A.A.H. (1997). Using sap flow gauges to quantify water uptake by tree roots from beneath the crop rooting zone in AF systems. *Agroforestry Systems* 35: 15-29.
- Howard, S.B., Ong, C.K., Rao, M.R., Muthuva, M. and Black, C.R. (1995). The partitioning of light and water in *Leuceana*-maize AF system. In: *Ecophysiology of Tropical Intercropping* [Eds. Sinoque, H. and Cruz, P.]. INDAR, Paris, pp. 123-235.

- Hsiao, T.C. (1973). Plant response to water stress. *Annual Review of Plant Physiology* 24: 519-570.
- Huda, A.K.S. and Ong, C.K. (1989). Crop simulation models and some implications for AF systems. In: *Meteorology and Agroforestry* (Eds. Reifsnyder, W.E. and Darnhofer, T.), International Centre for Research in Agroforestry, Nairobi, Kenya, pp. 115-124.
- Hurd, E.A. (1974). Phenotype and drought tolerance in wheat. *Agricultural Meteorology* 14: 39-55.
- Huxley, P.A. (1983). *Root distribution, growth and activity with reference to Agroforestry*. Plant Research and Agroforestry, ICRAF, Nairobi, Kenya, pp. 527-542.
- ICRAF, (1992). *A selection of useful trees and shrubs for Kenya*. International Centre for Research in Agroforestry, Nairobi, Kenya, 226pp.
- ICRAF, (1994). *Annual report for 1994*. International Centre for Research in Agroforestry, Nairobi Kenya, 45 pp.
- ICRAF, (1996). *Annual report for 1995*. International Centre for Research in Agroforestry, Nairobi Kenya, 72pp.
- ICRAF, (1998). *Tree and shrub species Data Base*. International Centre for Research in Agroforestry, Nairobi, Kenya.
- Jackson, K.E. (1983). Light climate and crop-tree mixtures. In: *Plant Research and Agroforestry, Proceedings of a Consultative Meeting held in Nairobi, Kenya*. Edited by P.A. Huxely, International Centre for Research in Agroforestry, Nairobi, Kenya, pp. 365-378.

- Jackson, J.E. and Palmer, J.W. (1989). Light availability at the tree-crop interface.
In: *Meteorology and Agroforestry. Proceedings of an International Workshop on the Application of Meteorology to Agroforestry Systems Planning and Management*. Edited by W.S. Reifsnnyder and T.O. Darnlofer. International Centre for Research in Agroforestry, pp. 391-400.
- Jackson, N.A., Griffiths, H. And Zeroni, M. (1995). Above ground biomass of seedling and semi-mature *Sesbania sesban*, a multipurpose tree species, estimated using allometric regressions. *Agroforestry Systems* 29: 103-112.
- Jackson, N.A., Wallace, J.S. and Ong, C.K. (1999). Tree pruning as means of controlling water use in an AF system in Kenya. *Forest Ecology and Management* 126: 133-148.
- Jain, R.C., Rai, M.P. and Rawat, J.K. (1991). Application of piecewise fitting of a model technique in construction of volume tables. *Indian Forester* 117: 1036-1040.
- Jarvis, P.G. (1975) Water transfer in plants. In: *Heat and Water Transfer in the Plant Environment* (Edited by De Vries, D.A. and Afgan, N.G.) India, pp. 369-400.
- Jeje, A.A. and Zimmermann, M.H. (1979). Resistance to water flow xylem vessels. *Journal of Experimental Botany* 30: 817-827.
- Jones. M. and Sinclair, F. (1996). Differences in root system responses of two semi-arid tree species to crown pruning. *Agroforestry Forum* 7: 24-27.
- Jonsson, K., Ong, C.K. and Odongo, J.C.W (1999). Influence of scattered Nere and Karite trees on microclimate, soil fertility and millet yield in Burkina Faso.

- Kakuru, A. (1993). The potential use of contour hedgerows for soil erosion control in highlands of Kabale district, South-West Uganda. M.Sc. Dissertation. Institute of Environment and Natural Resources, Makerere University, Kampala, Uganda, 243pp.
- Kang, B.T., Wilson, G.F. and Sipkens, L. (1981). Alley cropping maize (*Zea mays*) and *Leuceana leucocephala* Lam. in south Nigeria. *Plant and Soil* 63: 165-179.
- Karani, P.K. (1978). Pruning and thinning in a *P. patula* stand at Lendu plantation, Uganda. *Commonwealth Forestry Review* 57: 269-278.
- Karim, A.B., Savill, P.S., and Rhodes, E.R. (1991). The effect of young *Leuceana leucocephala* with hedges of the growth and yield of maize, sweet potato and cowpea in an AF system in Sierra Leone. *Agroforestry Systems* 16: 203-211.
- Kater, L.J.M., Kante, S. and Bundelman, A. (1992). Karite (*Vitelloria paradoxa*) and nere (*Parkia biglobosa*) associated with crops in South Mali. *Agroforestry Systems* 18: 89-105.
- Kessler, J.J. (1992). The influence of Karite (*Vitelloria paradoxa*) and nere (*Parkia biglobosa*) trees on sorghum production in Burkina Faso. *Agroforestry Systems* 17: 97-118.
- Khan, A.A.H. and Ong, C.K. (1996). A low cost heat pulse technique for measuring tree root water uptake. *Agroforestry Forum* 7 (2): 19-22.
- Khybri, M.L., Gupta, R.K, Sewa Ram and Tomar, H.P.S. (1992). Crop yields of rice and wheat grown in rotation as intercrops with three tree species in the outer hills of western Himalayas. *Agroforestry Systems* 17: 193-204.

- Kiepe, P. and Rao, M.R. (1994). Management of Agroforestry for the conservation and utilization of land and water resources. *Outlook in Agriculture* 23: 17-25.
- King, K.F.S. (1987) The history of Agroforestry. In: *Agroforestry: a decade of development* (Edited by: Stepler, H.A. and Nair, P.K.R.) ICRAF, Nairobi, 335pp.
- King, D.A. (1994). Influence of light level on the growth and morphology of saplings in Panamian forest. *American Journal of Botany* 81: 948-957.
- Kozlowski, T.T. and Winget, C.H. (1963). Patterns of water movement in forest trees. *Botanical Gazette* 124: 301-311.
- Lal, R. (1989). Agroforestry systems and soil surface management of a tropical alfisol. Water run-off, soil erosion and nutrient loss. *Agroforestry Systems* 8: 97-111.
- Lawson, G.J., Crout, N.M.J, Levy, P.E., Mobbs, D.C., Wallace. J.S., Cannell, M.G.R. and Bradley, R.G. (1995). The tree-crop interface: Representation by coupling of forest and crop process-models. *Agroforestry Systems* 30: 199-221.
- Larcher, W. (1975). In: *Physical Plant Ecology*. Springer-Verlag, pp. 215-221.
- Leaky, R.R.B. (1996). Definition of Agroforestry revised. *Agroforestry Today* 8(1): 5-7.
- Leaky, R.R.B. and Simon, A.J. (1997). The domestication and commercialization of indigenous trees in AF for alleviation of poverty. *Agroforestry Systems* 38: 165-176.

- Livesley, S. (1999). The distribution and dynamics of roots and soil nitrogen and water in tree row AF systems. PhD Thesis, The University of Reading, UK, pp. 98-109.
- London, J.R. (1991). Booker tropical soil manual (Eds.). *A handbook for soil survey and agricultural land evaluation in the tropics and subtropics*. Longmont Scientific and Technical, NY, 176pp.
- Lott, J.E., Khan, A.A.H., Ong, C.K. and Black, C.R. (1996). Sap flow measurements of lateral tree roots in AF systems. *Tree Physiology* 16: 995-1001.
- Lott, J.E., Howard, S.B., Ong, C.K. and Black C.R. (2000). Long term productivity of *Grevillea robusta*-based overstory AF system in semi-arid Kenya II. Crop growth and system performance. *Forest Ecology and Management* 139: 187-201.
- Luckhoff, H.A. (1949). The effect of live pruning on the growth of *Pinus patula*, *Pinus caribaea* and *Pinus taeda*. *South African Forestry Journal* 18: 25-55.
- Ludlow, M.M. (1978). Light relation of pasture plants. In: *Plant relation in Pastures* (Edited by Wilson, J.R.), CSIRO, Melbourne, pp. 35-49.
- MacDicken, K.G. (1990). Agroforestry management in the humid tropics. In: MackDicken K.G. and Vergara N.T. (eds.) *Agroforestry: Classification and Management*, Wiley, New York, pp. 98-149.
- MacDicken, K.G. (1994). Selection and management of nitrogen fixing trees. Winrock International and Bankok: FAO 210pp.
- MacFall, J.S., Johnson, G.A. and Kramer, P.J. (1991). Comparative water uptake by roots of different ages in seedlings of loblolly pine (*Pinus taeda* L.) *New Physiologist* 119: 551-560.

- McIntyre, B.D., Riha, S.J. and Ong, C.K. (1996). Light interception and evapotranspiration in hedgerow AF systems. *Agricultural and Forest Meteorology* 81: 31-40.
- Maheta, K.B., Kukadia, M.V., Vashi, B.G. and Jadeja, D.B. (1996). Effect of forest tree species on the yield potential of intercrops. *Indian Forestry* 122: 651-653.
- Malik, R.S. and Sharma, S.K (1990). Moisture extraction and crop yield as a function of distance from a row of *Eucalyptus tereticornis*. *Agroforestry Systems* 12: 187-195.
- Marshall, D.C. (1958). Measurement of sap flow in conifers by heat transport. *Plant Physiology* 33: 385-396.
- Marshall, R.S. and Willey, R.W. (1983). Radiation interception and growth in an intercrop of pearl millet/groundnut. *Field Crops Research* 7: 141-160.
- Matthews, R.B., Safell, R.A. and Campbell, G.S. (1987). An instrument to measure light distribution in row crops. *Agricultural and Forest Meteorology* 39: 177-184.
- Mathuva, M.N., Rao, M.R., Smithson, P.C. and Coe, R. (1998). Improving maize (*Zea mays*) yields in semi-arid Kenya: Agroforestry or inorganic fertilizers? *Field Crop Research* 55: 57-72.
- McIntyre, B.D., Riha, S.J. and Ong, C.K. (1996). Light interception and evapotranspiration in hedgerow AF systems. *Agricultural and Forest Meteorology* 81: 31-40.

- Mead, R., Curnow, R.N. and Hasted, A.M. (1993). *Statistical Methods in Agriculture and Experimental Biology*. Texts in statistical science. Chapman & Hall, 415pp.
- Messing, I., Afors, m., Radkvist, K. and Lewan, E. (1998). Influence of shelterbelt type on potential evaporation in an arid environment. *Arid Soil Research and Rehabilitation* 12(2): 123-138.
- Messier, C. (1992). Effects of neutral shade and growing media on growth, biomass allocation and competitive ability of *Gaultheria shallon*. *Canadian Journal of Botany* 70(11): 2271-2276.
- Miah, M.G., Garrity, D.P. and Aragon, M.L. (1995). Light availability to the understorey annual crops in AF system. In: *Ecophysiology of Tropical Intercropping* [eds. Sinoquet, H. and Cruz, P.]. INDAR, Paris, pp. 99-107.
- Michael, G.B. (1986). Concept of resource sharing in AF systems. *Agroforestry Systems* 4: 149-161.
- Miller, D.R., Vavrina, C.A. and Christensen, T.W. (1980). Measurement of sap flow and transpiration in ring-porous oaks using the heat pulse velocity technique. *Forest Science* 19: 291-296.
- Mobbs, D.C., Cannell, M.G.R., Crout, N.M.J., Lawson, G.J., Friend, A.D. and Arah, J. (1998). Complementarity of light and water use in tropical agroforests I. Theoretical model outline, performance and sensitivity. *Forest Ecology and Management* 102: 259-274.
- Monteith, J.L., and Unsworth, M.H. (1990). *Principles of environmental physics*. Edward Arnold, London, UK, 254pp.

- Monteith, J.L., Ong, C.K., and Corlett, J.E. (1991). Microclimatic interactions in AF systems. *Agroforestry Systems* 45: 31-44.
- Moore, S. (1993). Estimating stand transpiration in *Eucalyptus populea* woodland. Honour Thesis Australian National University, Canberra, 89pp.
- Mooney, A.H. (1980). Seasonality and gradients in the study of stress adaptation. In: *Adaptation of plants to water and high temperature stress*. Turner, N.C. and Kramer, P.J. (Eds). John Wiley and Sons, pp. 279-294.
- Morikawa, Y. (1972). Sap flow in *Chamaecyparis obtuse* in relation to water economy of wood plants. *Bulletin Tokyo University Forestry* 66: 251-297.
- Mugo, F.W. (1998). The effect of fuelwood demand and supply characteristics, land factors, and gender roles on tree planting and fuelwood availability in highly populated rural areas of Kenya. PhD Dissertation Presented to Faculty of the graduate School of Cornell University. Ithaca, USA, 241pp.
- Mulatya, J.M. (2000). Tree Root Development and Interactions in Drylands: Focusing on *Melia volkensii* with Socio-Economic Evaluations. PhD Thesis, University of Dundee, UK, 173pp.
- Mungai, D.N. (1991). A micrometeorological investigation of yield difference in alley cropping trials in the semi-arid areas of Machakos district Kenya. PhD Thesis, University of Nairobi, 378pp.
- Mwihomeke, S.T. (1990). Growth and fuelwood productivity of *Casuarina Montana*. Jungh and its limitation for AF use in the Tanzania highlands. In: *Advances in Casuarina Research and Utilization. Proceedings of the Second International Casuarina Workshop* (Edited by El-lakany, M..H. and Turnbull, J.W., Brewbaker, J.L.), Cairo, Egypt, pp. 152-161.

- Nair, P.K.R. (1983). Remarriage of crops and trees. *International Agricultural Development* 3: 5-8.
- Nair, P.K.R. (Ed., 1989). *Agroforestry systems in the tropics*. Kluwer Academic Publishers in Cooperation with ICRAF, Dordrecht and Nairobi, 664pp.
- Nair, P.K.R. (1991). State-of-the art in Agroforestry systems. *Forest Ecology and Management* 45: 5-29.
- Nair, P.K.R. (1993). *An introduction to Agroforestry*. Kluwer Academic Publishers, 499pp.
- Nair, P.K.R., Rao, M.R. and Fernandes, E.C.M. (1994). Tree-Crop interactions in sustainable Agroforestry systems. *Proceedings 15th World Congress of Soil Science*, Acapulco, Mexico, Volume 7a, pp. 110-137.
- Namirembe, S. (1999). Tree management and resource utilization in Agroforestry systems with *Senna spectabilis* in dryland of Kenya. PhD Thesis, University of Wales, Bangor 281pp.
- National Academy of Sciences (1994). *Casuarina: Nitrogen fixing tree species for energy production*. National Academy press, Washington D.C.
- Neumann, I.F. (1983). Use of trees in small holder agriculture in tropical highlands. In: *Environmentally Sound Agriculture* [Eds. Lockeretz, W], New-York, Praeger, pp. 351-374.

- Neumann, I.F. and Pietrowicz, P. (1987). Light and water availability in fields with and without trees: An example from Nyabisindu in Rwanda. In: *Meteorology and Agroforestry* [eds. Reifsnnyder, W.S. and Darnhofer, T.O.], ICRAF, Nairobi pp. 401-406.
- Newman, S.M. (1985). Low-cost sensor integrators for measuring the transmissivity of complex canopies to photosynthetically active radiation. *Agricultural and Forest Meteorology* 35: 243-354.
- Newman, S.M. (1989). Inexpensive instrumentation for monitoring PAR in AF. In: *Meteorology and Agroforestry* [Eds. Reifsnnyder, W.E. and Darnhofer, T.O.], ICRAF, Nairobi, Kenya pp. 297-304.
- Newman, S.M., Bennett, K. and Wu, Y. (1998). Performance of maize, beans and ginger as intercrops in Paulownia plantations in China. *Agroforestry Systems* 39: 232-240.
- Odhiambo, H.O. (1999). Root dynamics and soil water use in Agroforestry systems with *Grevillea robusta* and *Gliricidia sepium* in semi-arid Kenya. PhD thesis, University of Dundee, UK, 289pp.
- Ofori, F. and Stern, W.R. (1987). Cereal-Legume intercropping Systems. *Advances in Agronomy* 41: 41-90.
- Ogbuehi, S.H. and Brandle, J.R. (1982). Influence of windbreak-shelter on soybean growth, canopy structure and light relations. *Crop Science* 22: 264-273.
- Okorio, J. and Maghembe, J.M. (1994). The growth and yield of *Acacia albida* intercropped with maize (*Zea mays*) and beans (*Phaseolus vulgaris*) at Morogoro, Tanzania. MSc Thesis, Sokoine University of Agriculture, pp 165.

- Okorio, J., Byenkya, S., Wajja, N. and Peden, D.G. (1994). Comparative performance of seventeen upperstorey trees associated with crops in the highlands of Uganda. *Agroforestry Systems* 26: 185-203.
- Okorio, J. (2000). Light Interception and Water Use in Boundary planting Agroforestry Systems. PhD Thesis, The University of Reading, UK, pp 230.
- Olbrich, B.W. (1991). The verification of heat pulse technique for estimating sap flow in *Eucalyptus grandis*. *Canadian Journal of Forestry Research* 21: 836-841.
- Ong, C.K., Corlett, J.E., Singh, R.P and Black C.R. (1991a). Above and belowground interactions in AF systems. *Forest Ecology and Management* 45: 45-47.
- Ong, C.K., Odongo, J.C.W., Marshall, F. and Black C.R. (1991b). Water use by trees and crops: Five hypothesis. *Agroforestry Today* 3: 7-10.
- Ong, C.K., Rao, M.R. and Mathuva, M. (1992). Trees and crop competition, above and below ground. *Agroforestry Today* 4 (2): 4-5.
- Ong, C.K. and Khan, A.A.H. (1993). The direct measurement of water uptake by individual tree roots. *Agroforestry Today* 5: 2-5.
- Ong, C.K. and Black, C.R. (1994). Complementarity of resource use in intercropping and AF systems. In: *Resource capture by Crops* [Eds. Monteith, J.L., Scott, R.K. and Unsworth, M.H.], Nottingham University Press, Loughborough pp. 255-278.
- Ong, C.K. (1995). The 'dark side' of intercropping: manipulation of soil resources. *Ecophysiology of Tropical Intercropping. Conference Proceedings, Guadeloupe, INRA, France, 8pp.*

- Ong C.K. (1996). A frame work for quantifying the various effects of tree-crop interactions. In: *Tree-Crop interactions: A physiological Approach*. Ong CK and PA Huxley (Eds.). ICRAF, Nairobi pp. 1-24.
- Ong, C.K., Black, C.K., Marshal, F.M. and Corlett, J.E. (1996). Principles of resource capture and utilization of light and water. In: *Tree-Crop interactions: A physiological Approach*. Ong CK and PA Huxley (eds.). ICRAF, Nairobi pp. 255-278.
- Ong, C.K., Wilson, J., Deans, J.D., Mulatya, J., Raussen. And Musukwe, N.W. (2002). Tree-Crop interactions: manipulation of water use and root function. *Agricultural Water Management* 53: 171-186.
- Onyewout, L.O.Z., Ogigirigi M.A. and Stigter, C.J. (1994). A study of competitive effects between a *Eucalyptus camaldulensis* shelterbelt and an adjacent millet (*Pennisetum typhoides*). *Agriculture, Ecosystem & Environment* 51: 281-286.
- Palm, C.A. (1995). Contribution of Agroforestry trees to nutrient requirements of intercropped plants. *Agroforestry Systems* 30: 105-124.
- Passioura, J.B. (1981). Water collection by roots. In: *Physiology and Biochemistry of Drought Resistance in Plants*. Edited by L. Paleg and D. Aspinall. Academic Press, London New York, pp. 39-53.
- Passioura, J.B. (1988). Water in the Soil-Plant-Atmosphere Continuum. In: *Physiological Plant Ecology II. Water relations and Carbon Assimilation*. Edited by O.L. Lange, P.S. Nobel, C.B. Osmond and H. Ziegler. Springer-Verlag, Berline Heidgeberg New York, pp. 5-33.
- Pearcy, (1989). Radiation and light measurement. In: *Plant Physiological Ecology*

(Edited by Pearcy et al.). Chapman and Hall, London pp. 97-116.

Penman, H.L. and Schofield, R.K. (1941). Drainage and evaporation from fallow soil at Rothamsted. *Journal of Agricultural Science* 31: 74-109.

Perch, G. (1986). Mobile sampling of solar radiation under conifers. *Agricultural and Forest Meteorology* 37: 15-28.

Pidgeon (1972). The measurement and prediction of available water capacity of ferralitic soils in Uganda. *Journal of Soil Science* 23(4): 431-441.

Pinney, A. (1991). Farmer-augmented designs for participatory AF research. *Agroforestry Systems* 15: 259-274.

Poschen, P. (1986). An evaluation of the *Acacia albida*-based AF practices in the Hararghe highlands of eastern Ethiopia. *Agroforestry Systems* 4: 129-143.

Puri, S. and Bangarwa, K.S. (1992). Effects of trees on the yield of irrigated wheat crop in semi-arid regions. *Agroforestry Systems* 20: 229-241.

Radke, J.K. and Burrows, W.C. (1970). Soybean plant response to temporary field windbreaks. *Agronomy Journal* 62: 424-429.

Ralhan, P.K., Singh, A. and Dhanda, R.S. (1992). Performance of wheat as intercrop under poplar (*Populus deltoids*, Bartr.) plantation in Punjab (India). *Agroforestry Systems* 19: 217-222.

Rao, M.R., Sharma, M.M. and Ong, C.K. (1990). A study of the potential of hedgerow intercropping in semi-arid India using a two way systematic design. *Agroforestry Systems* 11: 243-258.

- Rao, M.R., Ong, C.K., Pathak, P. and Sharma, M.M. (1991). Productivity of annual cropping and AF systems on a shallow altisol in semi-arid India. *Agroforestry Systems* 15: 51-63.
- Rao, M.R., Nair, P.K.R. and Ong, C.K. (1998). Biophysical interactions in tropical AF systems. *Agroforestry Systems* 38: 3-50.
- Read, R.A. (1964). Tree windbreaks for the central great plains. Agricultural Handbook No. 250 Washington D.C., pp. 68.
- Rhoades, C. (1997). Single tree influence on soil properties in AF: lessons from natural forest and ecosystems. *Agroforestry Systems*, 35:71-94.
- Rimmington, G.M. (1985). A test of a model for light interception by mixtures. *Australian Journal of Plant Physiology* 13: 681-683.
- Rocheleau, D., Weber, F. and Field-Juma, A. (1988). *Agroforestry in dry land Africa*. ICRAF, Nairobi, 312pp.
- Roger, J.H. and Rao, M.R. (1990). Discovering the hard facts. Part I. Statistical considerations. *Agroforestry Today* 2: 4-7.
- Rosenberg, N.J. (1974). *The biological environment*. John Wiley and Sons, New-York, N.Y. 315pp.
- Rosenberg, N.J., Blad, B.C. and Verma, D.B. (1983). *Micro-climate: The biological environment*, 3rd edition. Willey and Sons, New York, USA, 315pp.
- Russell, E.W. (1988). *Russell's soil conditions and plant growth*. 11th ed. Longmont Group, UK Limited, 251pp.

- Rusten, E.P. (1990). *On-farm Agroforestry research: A case study of an indigenous knowledge system from the central hills of Nepal*. Paper presented at the workshop on participatory methods for on-farm AF research. ICRAF, Nairobi, 28pp.
- Sale, P.J.M. (1975). Productivity of vegetable crops in a region of high solar input. Field chamber measurements of French beans (*Phaseolus vulgaris* L.) and cabbages (*Brassica oleracea* L). *Australian Journal of Plant Physiology* 2: 461-470.
- Sanchez, P.A. (1987). *Soil productivity and sustainability in Agroforestry Systems*. *Agroforestry: a decade for development*, ICRAF, Nairobi, Kenya pp. 21-44.
- Sanchez, P.A. (1995). Science in Agroforestry. *Agroforestry Systems* 30(2) 5-55.
- Sanchez, P.A. and Leaky, R.R.B. (1996). Land-use transformation in Africa: Three determinants of balancing food security with natural resource utilization. In: 4th Congress of the European Society for Agronomy Journal 70: 1073-1076.
- Savage, M.J., Khuvutlu, I.N. and Bohene, H.A. (1992). Estimating water potential of porous media using filter paper. *South African Journal of Science* 88: 269-274.
- Scherr, J.S. and Muller, U.E. (1990). Evaluating AF interventions in extension projects. *Agroforestry Systems* 11: 259-280.
- Schroth, G. (1995). Tree root characteristics as criteria for species selection and system design in AF. *Agroforestry Systems* 30: 125-143.

- Schulze, E.D., Cremark, J., Matyssek, R., Penka, M., Zimmermann, R. and Vasicek, F. (1985). Canopy transpiration and water fluxes in the xylem of trunk of Larix and Picea trees; a comparison of xylem flow, prometer, and cuvette measurements. *Oecologia* 66: 475-483.
- Scott, C. (1985). *Sampling for monitoring and evaluation*. World Bank Washington, DC, USA, 44pp.
- Shackel, K.A., Johnson, R.S. and Medawar, C.K. (1992). Substantial errors in estimates of sap flow using the heat balance technique on woody stems under field conditions. *Journal of the American Society of Horticultural Science* 117: 351-356.
- Sheehy, H.E. (1985). Radiation. In: *Instrumentation for Environmental Physiology* (Edited by Marshall, R.S. and Woodward, K.G). Cambridge University Press, UK, pp. 5-18.
- Siaya District Development Plan (1993). Ministry of Finance and Planning, Nairobi, Kenya, 296pp.
- Simmonds, L.P. and Kuruppuarachchi, (1995). Dynamics of plant water uptake. In: *Modelling and Parameterization of the Soil-Plant- Atmosphere System*. A comparison of potato growth models. Kabat, P., Marshall, B., van den Broke, B.J., Vos, J. and van Keulen, H. (Eds.), Wageningen Peres, The Nezerlands, pp. 241-257
- Singh, G.B. (1987) Agroforestry: A decade of development. In: *Agroforestry in the Indian subcontinent: Past, present and future*. Steppler H.A and Nair PKR (Eds.). International Council for Research in AF, Nairobi, Kenya pp. 117-138.

- Singh, R.P., Ong, C.K. and Saharan, N. (1989). Above and belowground interactions in alley cropping in semi-arid India. *Agroforestry Systems* 9: 1281-1284.
- Singh, A., Dhanda, R.S. and Raihan, P.K. (1993). Performance of wheat varieties under poplar (*Populus deltoides*) Plantations in Punjab (India). *Agroforestry Systems* 22: 83-86.
- Singh, K.P., Kohli, R.K. and Batish, D.R. (1998). Effect of Poplar (*Populus deltoides*) shelterbelt on the growth of wheat in Punjab, India. *Agroforestry Systems* 40: 207-213.
- Sinoquet, H. and Caldwell, R.M. (1995). Estimation of light capture and partitioning in intercropping systems. In *Ecophysiology of Tropical Intercropping* (Edited by Sinoquet, H. and Crus, P.). INRAR, Paris pp. 79-97.
- Sinoquet, H., Mouliat, B., Gastall, F., Bonhomme, R. and Varlet-Grancher, C. (1990). Modelling the radiative balance of the components of a well-mixed canopy: application to a white clover-tall fescue mixture. *Acta Oecologia* 11: 469-486.
- Smith, D.A. and Allen, S.J. (1996). Measurement of sap flow in plants. *Journal of Experimental Botany* 47(305): 1833-1844.
- Smith, D.M., Jackson, N.M., Roberts, J.M. and Ong, C.K. (1999). Reverse flow of sap in tree roots and downward siphoning of water by *Grevillea robusta*. *Functional Ecology* 13: 256-264.
- Squire, G.R. (1990). *The Physiology of Tropical Crop Production*. CAB International, Wallingford, UK, 236pp.

- Srinivasan, V.M., Subramanian, S. and Rai, R.S.V. (1990). Studies on intercropping with multipurpose trees-resource sharing ability of the trees. In: *Advances in Casuarina Research and utilization, Proceedings of the Second International Casuarina Workshop*, Cairo, Egypt, January 15-20, 1990. (Edited by M.K.El-Lakany, J.W. Turnbull and J.L. Brewbaker). Desert Development Centre. American University in Cairo, Egypt.
- Ssckabembe, C.K., Hendcrlong, P.R. and Larson, M. (1997). Effect of hedgerow orientation on maize light interception and yield in black locust alleys. *International Tree Crops Journal* 9: 109-118.
- Staple, W.J. and Rehane, J.J. (1955). The influence of field shelterbelts on wind velocity, evaporation, soil moisture and crop yield. *Canadian Journal of Agricultural Sciences* 35: 440-453.
- Steinberg, S. (1988). Dynamax trunk-flow gage test: insulation and time of attachment test. In *Technical Application Report 2*, Texas A&M University, USA 114pp.
- Steven, D.R. and Charles, A.S. (1990). *Effect of tree root pruning adjacent to windbreaks on corn and soybeans*. University of Nebraska, Concord, 68728, 5pp.
- Stone, J.F. and Shirazi, G.A. (1975). On the heat pulse method for measurement of apparent sap velocity in stems. *Planta* 122: 169-177.
- Stirling, C.M. (1988). Environmental effects on partitioning and development of groundnuts. PhD Thesis, University of Nottingham.

- Stirling, C.M., Williams, J.H., Black, C.K. and Ong, C.K. (1990). The effect of timing of shade on development, dry matter production and light use efficiency of groundnut (*Arachis hypogaea* L.) under field conditions. *Australian Journal of Agricultural Research* 41: 633-644.
- Stoeckeler, S.H. (1962). *Shelterbelts influence on greatplains field environment and Crops*. Research report 62 US Department of Agriculture, Washington DC 27pp.
- Streeter, T. (1993). Water use strategies of *Eucalyptus largiflorens* on a semi-arid, Saline flood plain. Honours Thesis, Flinders University, Adelaide, 109pp.
- Swanson, R.H. and Whitfield, D.W.A. (1981). A numerical analysis of heat pulse velocity theory and practice. *Journal of Experimental Botany* 32: 229-239.
- Swanson, R.H. (1984). Significant historical developments in thermal methods for measuring sap flow in trees. *Agricultural and Forest Meteorology* 72: 113-132.
- Swinkels R.A., Franzel S., Sheperd K.D., Ohlsson E. and Nudufa J.K. (1997). The economics of short rotation improved fallows: evidence from areas of high population density in western Kenya. *Agricultural Systems* 38: 139-151.
- Synadon, R.W. and Harris, P.M. (Eds.) (1981). Interactions below ground:- the use of nutrients and water. *Proceedings of an International Workshop on Intercropping*. Hyderabad, India. ICRISAT, 201pp.
- Szeicz, J. (1974a). Solar radiation for plant growth. *Journal of Applied Ecology* 11: 617-636.

- Taylor, H.M. and Klepper, B. (1987). Water relation of cotton: Root growth and water use as related to top growth and soil water content. *Agronomy Journal* 66: 567- 584.
- Tefera, A.T. (1999). Farmers tree pruning practices in Embu and Siaya, Kenya. In: *Project Initiation Workshop on Pruning Effects on Root Function*, (Edited by Wilson, J. et al.). 19 - 21 January 1999, Kabale, Uganda, Kabale, Uganda, pp. 6-7.
- Tefera, A.T., Rao, M.R, Mathuva, M.N. and Atta-Krah, K. (2001). Farmer-Participatory Evaluation of *Grevillea robusta* in Boundary plantings in Semi-Arid Kenya. *Forests, Trees and Livelihoods* 11: 13-27.
- Tejwani, K.G. (1994). *Agroforestry in India*. Oxford and IBH Publ. Co. Ltd, New Delhi, India, 67pp.
- Thorburn, P.J., Hatton, T.J. and Walker, G.R. (1993). Combining measurements of transpiration and stable isotopes of water to determine ground water discharge from forests. *Journal of Hydrology* 150: 563-587.
- Torquebiau, E. and Kwesiga, F. (1996). Root development in a *Sesbania sesban* fallow-maize system in Eastern Zambia. *Agroforestry Systems* 34: 193-211.
- Tyndall, B. (1996). The socio-economics of *Grevillea robusta* within the coffee land use system of Kenya. AFRENA report No. 109, 91pp.
- Tyree, M.T. and Ewers, F.W. (1991). Tansley Review. The hydraulic architecture of trees and other woody plants. *New Phytologist* 119: 345-360.
- User-Manual (1998). ThetaProbe Soil moisture Sensor Type ML2. Delta T Devices Ltd, Cambridge, UK, 22pp.

- Useful Trees and Shrubs of Tanzania (1994). Identification, propagation and Management for Agricultural and Pastoral Communities. Regional Soil Conservation Unit/Sida. Technical Hand Book No.6 542pp.**
- Vandenbeldt, R.J., Brenner, A.J. and Sinclair, F.L. (1990). *Tree-crop interactions in Agroforestry Systems*. Paper presented at the 19th IUFRO world congress, pp. 292-303.**
- Vandenbeldt, R.J. and Williams, J.H. (1992). The effect of soil surface temperature on the growth of millet in relation to the effect of *Faidherbia albida* trees. *Agriculture and Forest Meteorology* 60: 93-100.**
- VanDermeer, J. (1989). *The Ecology of Intercropping*. Cambridge University Press, Cambridge, UK, 237pp.**
- Von Maydell, H.J. (1987). *Agroforestry: A decade of development In: Agroforestry in the dry zone of Africa: Past present and future*. (Edited by Stepler HA and Nair PKR) Nairobi, 89-116 pp.**
- Van Noordwijk, M. and Purnomosidhi, P. (1995). Root architecture in relation to tree-soil crop interaction and shoot pruning in AF. *Agroforestry Systems* 30: 161-173.**
- van Noordwijk, M., Lawson, G., Soumare, A., Groot., J.J.R. and Hairiah, K. (1996). Root distribution of trees and crops: competition and/or complementarity. In: *Tree-Crop interactions: A Physiological approach* (Edited by Ong, C.K. and Huxley, P). CAB International, Wallingford, Oxford, UK, pp. 319-364.**
- Van Roode, M. (1992). *Agroforestry and the availability of soil water: a study on soil water in an AF system in Kalalu, Kenya*. M.Sc. Dissertation. University of Utrecht, The Netherlands, 184pp.**

- Varlet-Grancher, C. and Bonhomme, R. (1974). Utilization de l'energie solaire par une culture de Vigna sinesis. III Evolution du rendement energetique pendant la phase vegetative. *Annals Agronomie* 25: 811-819)
- Wallace, J.S., Jackson, N.A. and Ong, C.K. (1995). *Water balance of Agroforestry Systems on hill-slopes. Final report to the ODA Forestry Research Program.* Institute of Hydrology report ODA 95/10, 39pp.
- Wallace, J.S., Jackson, N.A. and Ong, C.K. (1996). *Water balance of Agroforestry systems on hillslopes. Final Report to the ODA Forestry Research Program.* Institute of Hydrology, Wallingford, ODA 95/10, 39pp.
- Wear, P.R. and Clement, C.R. (1980). *Plant ecology.* McGraw-Hill Book Company, 220pp.
- Weatherley, P.E. (1979). The hydraulic resistance of the soil-root interface-a cause of water stress in plants. In: *The soil-Root Interface.* (Edited by Harely, J.L. and Russell, R.S.) Academic Press Limited, London, pp. 14-39pp.
- Whitehead, D.T., Kleinkopf, G.E., Porter, L.K. and Leggett, G.E. (1981). Nitrogen sources for bean seed production. *Agronomy Journal* 73: 660-664.
- Willatt, S.T. (1971). Model of soil water use by tea. *Agricultural Meteorology* 8: 341-351.
- Willey, R. W. (1979). Intercropping:- Its importance and Research needs. I. Competition and yield advantages. *Field Crops Abstracts* 32: 1-10.
- Willey, R. W., Natarajan, M., Reddy, M.S. and Rao, M.R (1986). Cropping systems with groundnut: Resource use and productivity. In: *Agrometeorology of Groundnut. Proceedings of International Symposium.* ICRISAT Sahelian Centre Niamey, Niger pp. 193-205.

- Wilson, A.M., Hyder, D.N. and Tomlinson, H.F. (1998). Drought resistance characteristics of blue gram seedlings. *Agronomy Journal* 68: 479-484.
- Wilson, J., Deans, J.D., Wajja-Musukwe, N., Raussen, T. and Ong, C.K. (1999). *Pruning Effects on Root Function*. Project Initiation Workshop Kabale. Uganda, 19th - 21st January 1999. 16pp.
- Wormald, T.J. (1975). *Pinus patula*. Tropical Forestry Paper No. 7. Commonwealth Forestry Institute, Oxford, U.K. 172pp.
- Yadar, J.P., Sharma, K.K. and Khanna, P. (1993). Effects of *Acacia nilotica* on mustard crop. *Agroforestry Systems* 21: 91-98.
- Young, A. (1989). *Agroforestry for soil conservation*. Wallingford, UK, pp 284.
- Young A. (1997). *Agroforestry for soil management*. 2nd (Ed). CABI, ICRAF, Nairobi, 276pp.
- Zang, D., Beadle, C.L. and White, D.A. (1996). Variation of sapflow velocity in *Eucalyptus globules* with position in sapfwood and use of correction coefficient. *Tree Physiology* 16: 697-703.
- Zhang, P. (1996). Water use in a Poplar Tree-Pasture system. PhD. Thesis, The University of Reading, UK, 265pp.
- Zimmermann, M.H. (1983). *Xylem Structure and the Ascent of Sap*. Springer-Verlag Berlin Heidelberg, 143pp.

APPENDICES

APPENDIX 1: Questionnaire for a targeted survey of farmers to gather information on trees and tree based technologies in Siaya, Western Kenya

Enumerator's Name.....
Date of this interview.....

SECTION 1.**PERSONAL DETAILS ON INTERVIEWEE**

1. Farmers Name.....Sex.....
2. Province.....District.....Village.....
3. Case number (Code).....
4. Age.....
5. Marital status:

Married..... 1	Divorced..... 3
Single..... 2	Widowed..... 4
6. Number of children.....
7. If male headed household, how many wivcs.....
8. Tribe.....
9. Interview conducted with.....

Male head and the Wife..... 1	
Female head (husband lives away)..... 2	
Female head husband died..... 3	
Others (specify)..... 4	
10. Status of interviewee

Owner..... 1	Squatter..... 3
Tenant..... 2	Other..... 4
11. Who is the decision maker of the farm activities?.....

Key: Male head 1
Female head 2
Others (Specify)..... 3
12. What is the age class of the decision maker?.....

20-30..... 1	51-60..... 4
31-40..... 2	61-70..... 5
41-50..... 3	70+ 6
13. Have you ever been to school? Ycs.....1 No..... 2
14. If yes, up to what level?.....

Adult education..... 1	Secondary..... 3
Primary..... 2	Higher (specify)..... 4
15. What is the major occupation of the decision maker and where does he/she live?.....

<u>Major occupation</u>		<u>Live</u>	
Farming..... 1		On-farm..... 1	
Farming and cottage industries..... 2		Off-farm..... 2	
Schooling..... 3			
On-farm employment 4			
Off-farm employment 5			
16. What is the approximate size of your holding?.....

17. What is the main source of income of the household?.....

Source of income	Wealth Group
From the farm..... 1	Low income..... 1
Off-farm..... 2	Medium income..... 2
Others..... 3	Above average income..... 3

18. What is the size of the household (family size)?.....

SECTION 2.

1. Existing trees on-farm

Plot	Common trees on farm (Species/Local name)		No. of trees	Purpose	Niche
	Natural	Planted			
1					
2					
3					
4					
5					
6					

Key for Niche:

<i>III: Inside homestead.....</i>	<i>1</i>
<i>Hedge, Live fence and individual trees</i>	
<i>III: Hedgerow in cropland.....</i>	<i>2</i>
<i>FL: Fallowland.....</i>	<i>3</i>
<i>GR: Grazing land.....</i>	<i>4</i>
<i>EX: External border.....</i>	<i>5</i>
<i>IB: Internal border.....</i>	<i>6</i>
<i>OT: Others.....</i>	<i>7</i>

Purpose:

<i>Fuelwood..... 1</i>	<i>Fodder..... 8</i>
<i>Poles/Timber..... 2</i>	<i>Cash generation..... 9</i>
<i>Fences..... 3</i>	<i>Fruits..... 10</i>
<i>Boundary demarcation..... 4</i>	<i>Shade..... 11</i>
<i>Soil conservation..... 5</i>	<i>Amenity..... 12</i>
<i>Compost or mulch..... 6</i>	<i>Protection (animals/thieves)..... 13</i>
<i>Windbreak..... 7</i>	

2. What are the opportunities for tree planting on your farm?.....

Opportunities:

<i>Availability of planting site..... 1</i>
<i>Inside homestead</i>
<i>Hedgerow in cropland</i>
<i>Fallowland</i>
<i>Grazingland</i>
<i>External border</i>
<i>Internal border</i>
<i>Availability of seeds/seedlings..... 2</i>
<i>Forest service</i>
<i>NGO's</i>
<i>Women's group</i>
<i>Own nursery</i>
<i>Neighbours</i>
<i>Other sources</i>

3. Who planted the trees?

<i>Husband..... 1</i>	<i>Wife..... 2</i>
<i>Children..... 3</i>	<i>Hired labour..... 4</i>

4. Does he/she face any constraints in tree planting?
 Yes.1 No.....2

5. If yes what are the constraints?
 Availability of tree seeds..... 1
 Availability of tree seedlings..... 2
 Difficulties in raising seedlings..... 3
 Availability of water..... 4
 Availability of nursery materials..... 5
 Lack of knowledge..... 6
 Stray cattle..... 7
 Termite..... 8
 Availability of labour..... 9
 Land tenure..... 10

6. What efforts have you taken to overcome the above constraints?
 Obtain own seeds..... 1
 Raise own seedlings..... 2
 Advice and help from government and NGO's..... 3
 Control animal movement..... 4
 Enforcement of community laws..... 5
 Hire labour..... 6
 Apply pesticides..... 7

7. What are the pests and diseases observed affecting trees?

SPECIES	PESTS	DISEASES

8. Farmers view on tree planting.....
 Very much interested..... 1
 Moderately interested..... 2
 Interested only with external help..... 3
 Not interested in planting trees..... 4

9. Farmers Knowledge of trees and their preference:

Species	FU (1)	PO (2)	FE (3)	FO (4)	TB (5)	SH (6)	SC (7)	FR (8)	WB (9)	BD (10)	OT (11)
1											
2											
3											
4											
5											
6											
7											
8											
9											
10											

Key: FU = Fuelwood SH = Shade OT = Others
 PO = Poles SC = Soil conservation
 FE = Fences FR = Fruits
 FO = Fodder WB = Windbreaks
 TB = Timber BD = Boundary plantings

12. How do you full fill your demand of wood?.....

Collect..... 1
 Buy..... 2
 Produce..... 3
 A combination of all (collect, buy and produce)..... 4
 Others (Specify)..... 5

13. Rank the following energy types in terms of their extent of use for household cooking (1 indicates the highest priority)

Source	Rank	Quantity/year
Firewood (1)		
Charcoal (2)		
Paraffin (3)		
Dung (4)		
Crop residues (5)		
Electricity (6)		
Others, specify (7)		

14. Which are the first five tree species you would prefer to grow and in which niche?

Species	Niche	Uses
1		
2		
3		
4		

Niche: Use same code as above

19. Do you grow trees adjacent to crops?.....

Yes.....1 No.....2

20. If Yes, Which tree and crop species do you intercrop? in which Niche and Arrangement?

<u>Tree species</u>	<u>Crop species</u>	<u>Arrangement</u>
.....
.....
.....
.....

Niche (use above code) Arrangement: Line (1), Scattered (2), Block (3)

21. If you plant trees along agricultural fields, how many rows of trees are there?.....and what is the length of the border?.....

22. If you plant trees along the boundary, was there any discussion between the neighbours ?

Yes.....1 No.....2

23. If yes, any agreement made?.....

24. If no, please explain why?.....

25. What is the average distance between rows?.....

26. What is the in-row spacing?.....

27. What is the approximate height of the trees?.....

28. After how many years did you cut your trees for poles?.....

28. How much do trees shade the adjacent crop?.....

Heavy shading.....	1	Light shading.....	3
Moderate shading.....	2	No shading (trees are small).....	4

29. How do you express crop production in the two meters next to trees

A lot greater than in the rest of the plot.....	1
Somehow greater than in the rest of the plot.....	2
About the same as in the rest of the plot.....	3
A lot less than in the rest of the plot.....	4
No adjacent crop.....	5

47. Where do you sell your tree products?.....
- Buyers come and collect..... 1
 - Local market near by..... 2
 - Near by sawmills..... 3
48. After tree pruning and pollarding, do you observe any changes in crop yields adjacent to trees...?
- Yes.....1
 - No.....2
49. If yes, is the change positive or negative?.....
50. If negative, what do you think is the problem?
- Root competition..... 1
 - for nutrients
 - for water
 - for space
 - Branches left still cast shade..... 2
 - Trees produce toxic chemicals to crops..... 3
51. If you observe root competition how do you manage the problem?
- Dig root trenches 1
 - Leave the area close to tree roots open (no crops)..... 2
 - Don't mind (value tree products)..... 3
 - Others specify..... 4
52. How do you express soil fertility?
- Colour..... 1
 - Soil moisture content..... 2
 - Others (specify)..... 3
53. How does soil fertility differ with distance from the tree?.....
-

SECTION 3.
CASH GENERATION

SOURCE	1ST PRIORITY	2ND PRIORITY	3 RD PRIORITY
Crops (1)			
Livestock (2)			
Trees (3)			
Fruits (4)			
Off-farm employment (5)			
Hire out labour (6)			
Others, specify (7)			

SECTION 4.

OPINIONS:

1. Farmer:

a) What is your general opinion about your farm?

.....

...

b) What is your opinion about the village extension services?

.....

...

c) What are the major constraints you encounter?

.....

...

2. Enumerator:

.....

APPENDIX 2: Informal questions assessed from extension workers in Siaya, western Kenya

1. General

Name.....Age.....Sex.....
 Title.....
 Area of responsibility.....
 For how long have you worked in this area?.....
 Where were you trained?.....
 What are your main duties as the extension officer?

What are the main constraints to tree growing in the target area?
 1.....
 2.....
 3.....
 4.....
 5.....

2. What extension activities would you propose to increase tree planting?

In your assessment, what is the demand situation for tree seedlings?

Low..... 1 High..... 3
 Average..... 2 Very high..... 4

3. What tree species are greatest demands?

6. What are the main sources of tree seedlings for the target area?

7. About how many requests do you get per week to visit farmers?.....
8. How many of these are you actually able to visit?
9. If you can't visit all, what are the limiting factors?

10. What are the major requests?.....

Type of trees to plant.....	1	How to look after trees.....	4
Where to get seedlings.....	2	How to plant seedlings.....	5
How to prune trees.....	3	Others (specify).....	6

11. What are the major tree planting needs?

For soil and water conservation.....	1
For inter-cropping with crops.....	2
For woodfuel.....	3
For fence/hedge.....	4
For poles/timber.....	5
For windbreak and demarcation.....	6
For shade and amenity.....	7
For food (fruits).....	8
For cash generation.....	9

12. Indicate tree species you advice farmers to plant adjacent to crops:

Species	Uses
.....

13. What is your observation on tree crop interaction?
